

Ride Mower

YTH2448

96013000700

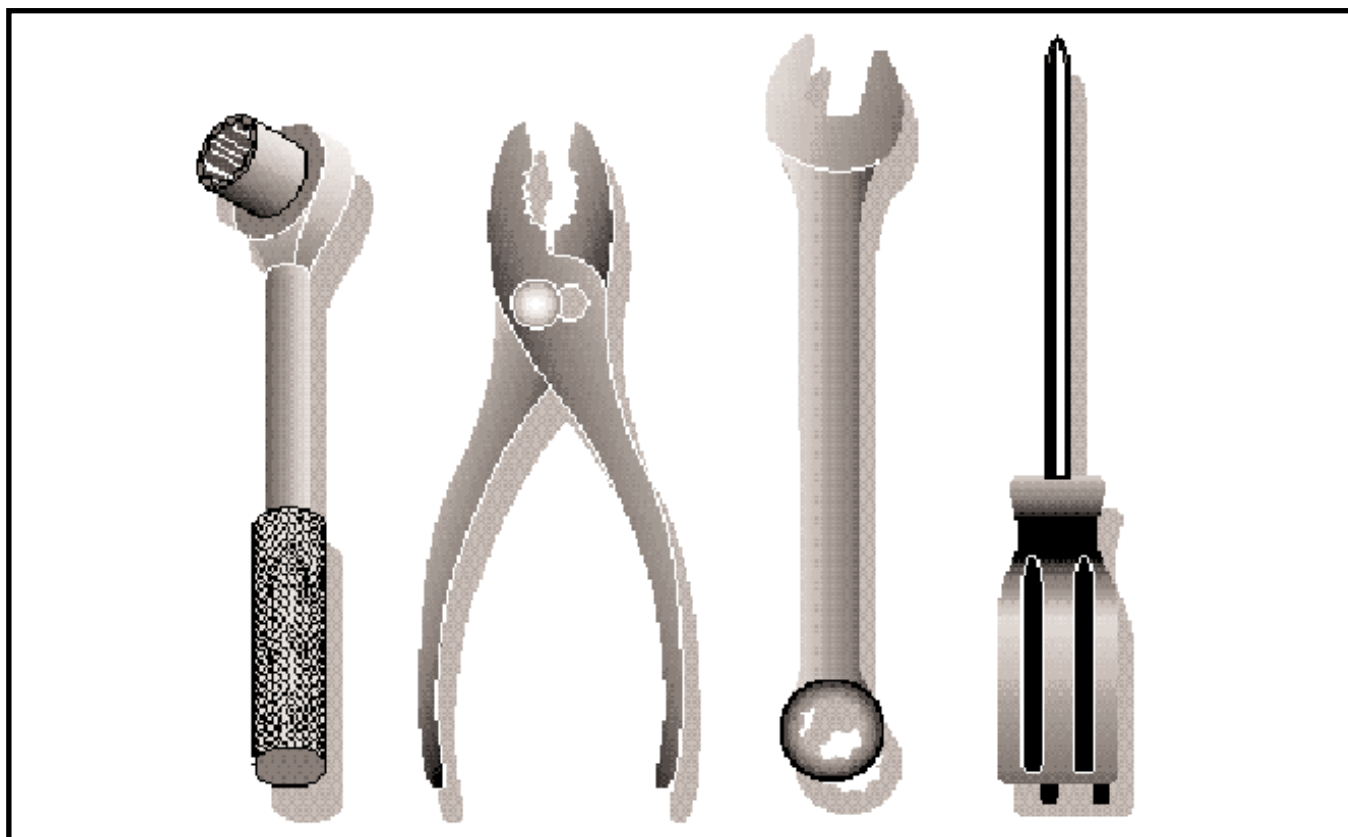

TRACTOR-MODEL NUMBER YTH2448 (96013000700), PRODUCT NO. 960 13 00-07 SCHEMATIC

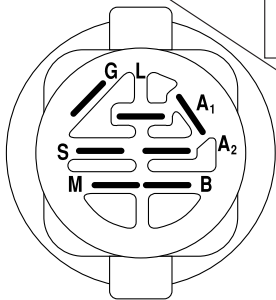
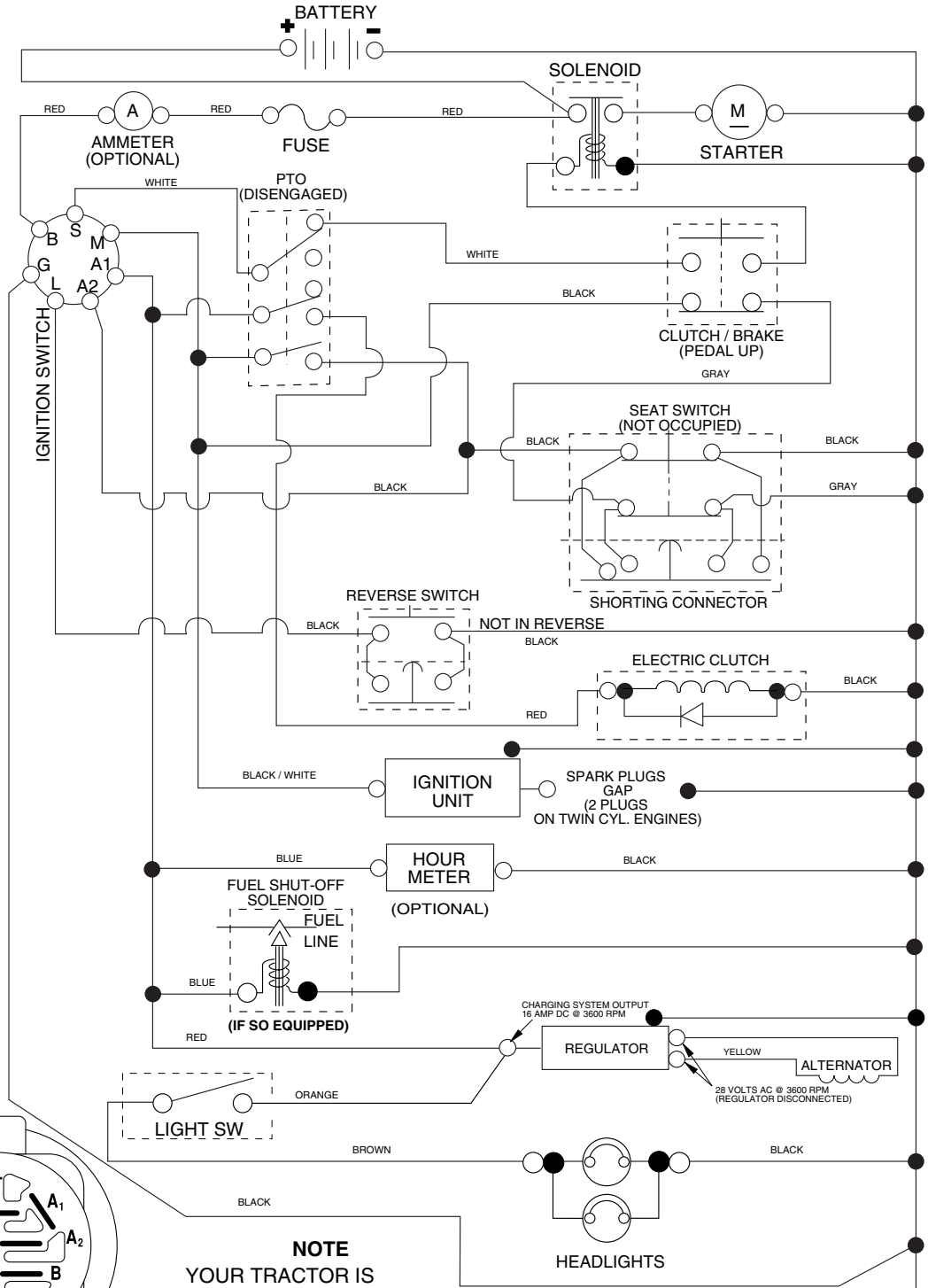

IGNITION SWITCH

POSITION	CIRCUIT "MAKE"
OFF	M+G+A1
RUN/OVERRIDE	B+A1
RUN	B+A1 L+A2
START	B + S + A1

02833

NOTE
YOUR TRACTOR IS EQUIPPED WITH A SPECIAL ALTERNATOR SYSTEM. THE LIGHTS ARE NOT CONNECTED TO THE BATTERY, BUT HAVE THEIR OWN ELECTRICAL SOURCE. BECAUSE OF THIS, THE BRIGHTNESS OF THE LIGHTS WILL CHANGE WITH ENGINE SPEED. AT IDLE THE LIGHTS WILL DIM. AS THE ENGINE IS SPEEDED UP, THE LIGHTS WILL BECOME THEIR BRIGHTEST.

NON-REMOVABLE CONNECTIONS

REMOVABLE CONNECTIONS

WIRING INSULATED CLIPS

NOTE: IF WIRING INSULATED CLIPS WERE REMOVED FOR SERVICING OF UNIT, THEY SHOULD BE REPLACED TO PROPERLY SECURE YOUR WIRING.

REPAIR PARTS

TRACTOR-MODEL NUMBER YTH2448 (96013000700), PRODUCT NO. 960 13 00-07
ELECTRICAL

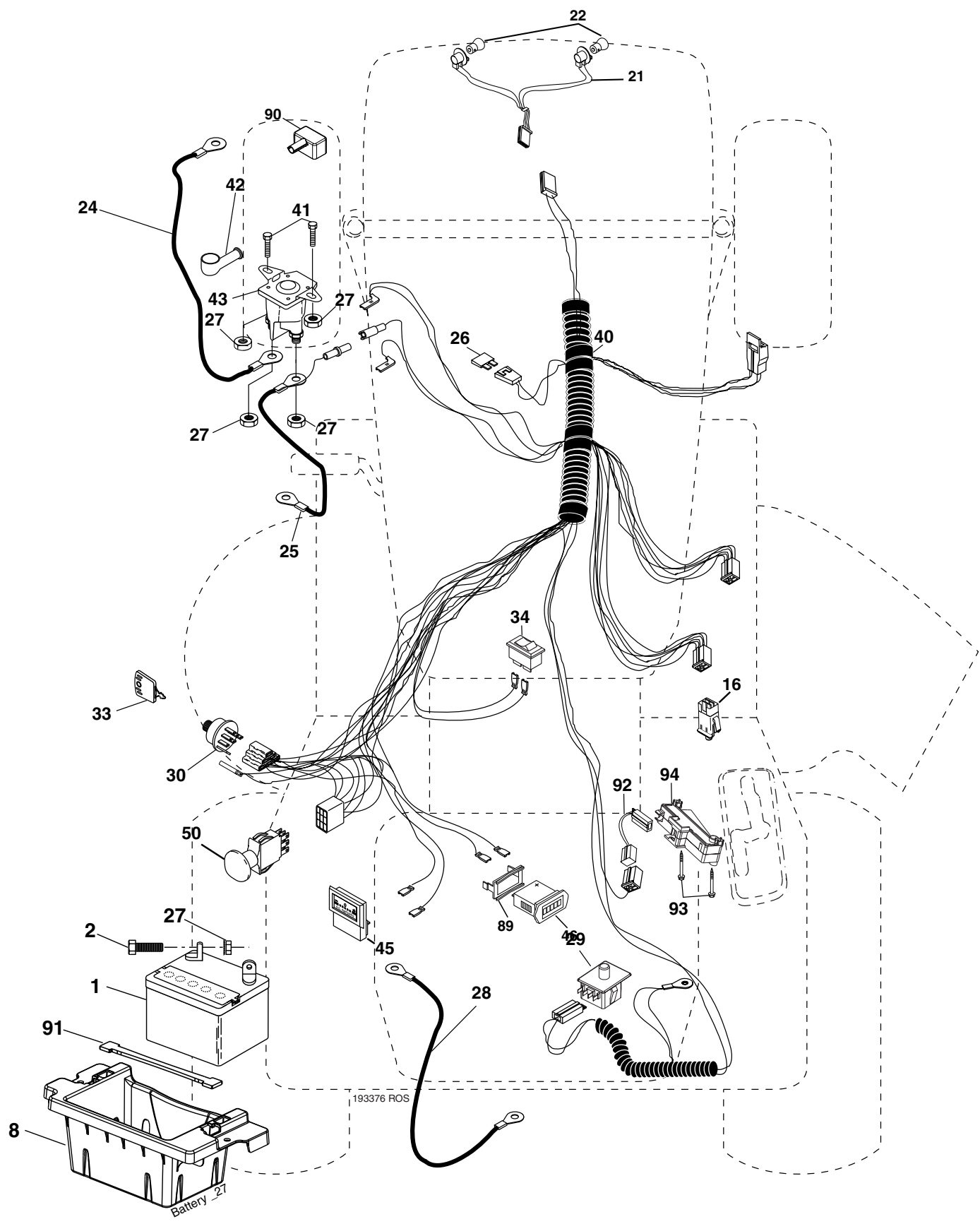

REPAIR PARTS

TRACTOR-MODEL NUMBER YTH2448 (96013000700), PRODUCT NO. 960 13 00-07
ELECTRICAL

KEY NO.	PART NO.	DESCRIPTION
1	532 14 49-27	Battery
2	874 76 04-12	Bolt Hex Hd 1/4-20 unc x 3/4
8	532 18 64-91	Cable Starter
16	532 17 61-38	Switch Interlock Push-In
21	532 18 37-59	Harness Asm Light W/Bulbs
22	532 00 41-52	Bulb Light
24	532 12 47-80	Cable Starter
25	532 14 61-48	Cable Battery
26	532 17 51-58	Fuse
27	873 51 04-00	Nut Keps Hex 1/4-20 unc
28	532 14 54-91	Cable Ground
29	532 19 27-49	Switch Seat
30	532 19 33-50	Switch Ign
33	532 14 04-01	Key Ign
34	532 11 07-12	Switch Light/Reset
40	532 19 33-76	Harness Ign.
41	871 11 04-08	Bolt 1/4-20 x 1/2
42	532 13 15-63	Cover Terminal
43	532 17 88-61	Solenoid
45	532 12 28-22	Ammeter Rectangular
46	532 16 96-35	Hourmeter Snap-In
50	532 17 46-51	Switch, PTO
55	817 49 05-08	Screw Thdrol 5/16-18 x 1/2
89	532 16 96-39	Bracket Snap-In Hourmeter
90	532 18 04-49	Cover Terminal Battery
91	532 19 02-70	Strap Battery
92	532 19 34-65	Harness Pigtail Reverse Switch
93	532 19 25-40	Screw Plastite 10-1/4 x 2.0
94	532 19 18-34	Module Reverse Switch

NOTE: All component dimensions given in U.S. inches.
1 inch = 25.4 mm.

REPAIR PARTS

TRACTOR-MODEL NUMBER YTH2448 (96013000700), PRODUCT NO. 960 13 00-07
CHASSIS AND ENCLOSURES

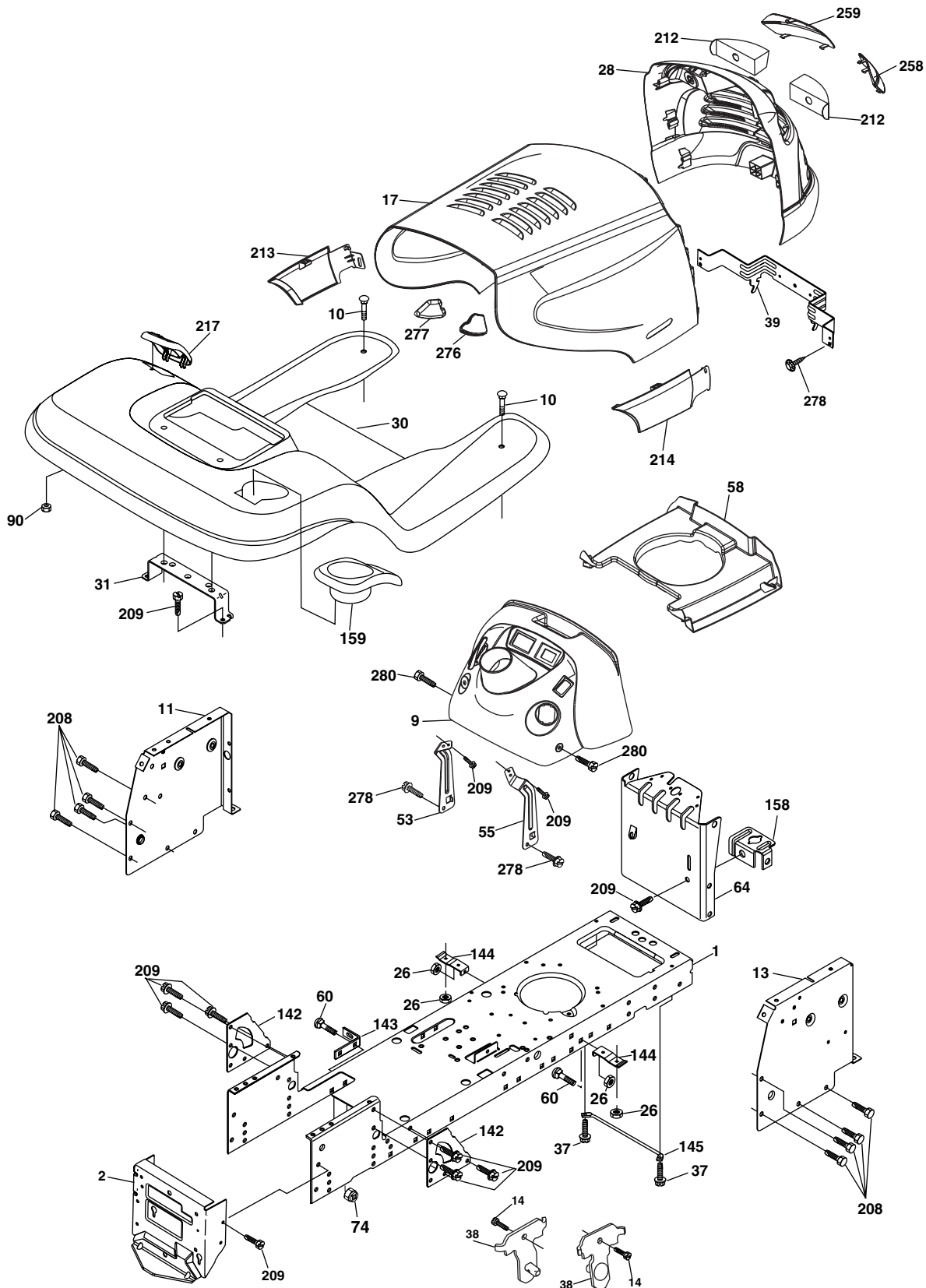

chassis_elite husqy_4

REPAIR PARTS

TRACTOR-MODEL NUMBER YTH2448 (96013000700), PRODUCT NO. 960 13 00-07
CHASSIS AND ENCLOSURES

KEY NO.	PART NO.	DESCRIPTION
1	532 17 46-19	Chassis
2	532 17 65-54	Drawbar
9	532 19 54-20	Dash
10	872 14 06-08	Bolt 3/8-16 x 1
11	532 17 49-96	Panel Dash Lh
13	532 18 17-19	Panel Dash Rh
14	817 49 06-08	Screw Thdrol 3/8-16 x 1/2
17	532 18 99-77	Hood
26	873 80 06-00	Nut Lock Hex W/Ins 3/8-16 unc
28	532 18 82-69	Grille/Lens Asm (Includes Key Nos. 212, 258, 259)
30	532 19 48-06	Fender
31	532 13 99-76	Bracket Fender
37	817 49 05-08	Screw Thdrol 6/16-18 x 1/2 TYT
38	532 17 57-10	Bracket, Asm. Pivot Mower Rear
39	532 17 47-14	Bracket Pivot
53	532 18 83-73	Bracket Dash Lh
55	532 18 83-72	Bracket Dash Rh
58	532 18 93-52	Duct Hood
60	872 14 06-06	Bolt RdHd Sqnk 3/8-16 unc x 3/4
64	532 17 49-97	Dash Lower
74	873 68 06-00	Nut Crownlock 3/8-16 unc
90	532 12 43-46	Nut Self-Thd Wsh-Hd 1/4 Zinc
142	532 17 57-02	Plate Reinforcement STLT
143	532 18 66-89	Bracket Swaybar Chassis
144	532 17 55-82	Bracket Footrest
145	532 15 65-24	Rod Pivot Chassis/Hood
154	532 16 18-97	Bracket Dash Rh
155	532 16 19-00	Bracket Dash Lh
158	532 16 20-37	Bracket Parking Brake
159	532 19 24-04	Cupholder
208	817 67 06-08	Screw Thdrol 3/8-16 x 1/2
209	817 00 06-12	Screw Hexwsh Thdrol 3/8-16 x 3/4
212	532 18 82-67	Insert Lens
213	532 18 99-79	Skirt Grille LH
214	532 18 99-78	Skirt Grille RH
217	532 18 54-36	Console Fuel Window
258	532 18 99-81	Lens RH
259	532 18 99-82	Lens LH
276	532 18 92-74	Bumper Hood RH
277	532 18 92-75	Bumper Hood LH
278	532 19 16-11	Screw 10 x 3/4 Single Lead Hex
280	817 00 06-16	Screw 3/8-16 x 1

NOTE: All component dimensions given in U.S. inches
1 inch = 25.4 mm

REPAIR PARTS

TRACTOR-MODEL NUMBER YTH2448 (96013000700), PRODUCT NO. 960 13 00-07
DRIVE

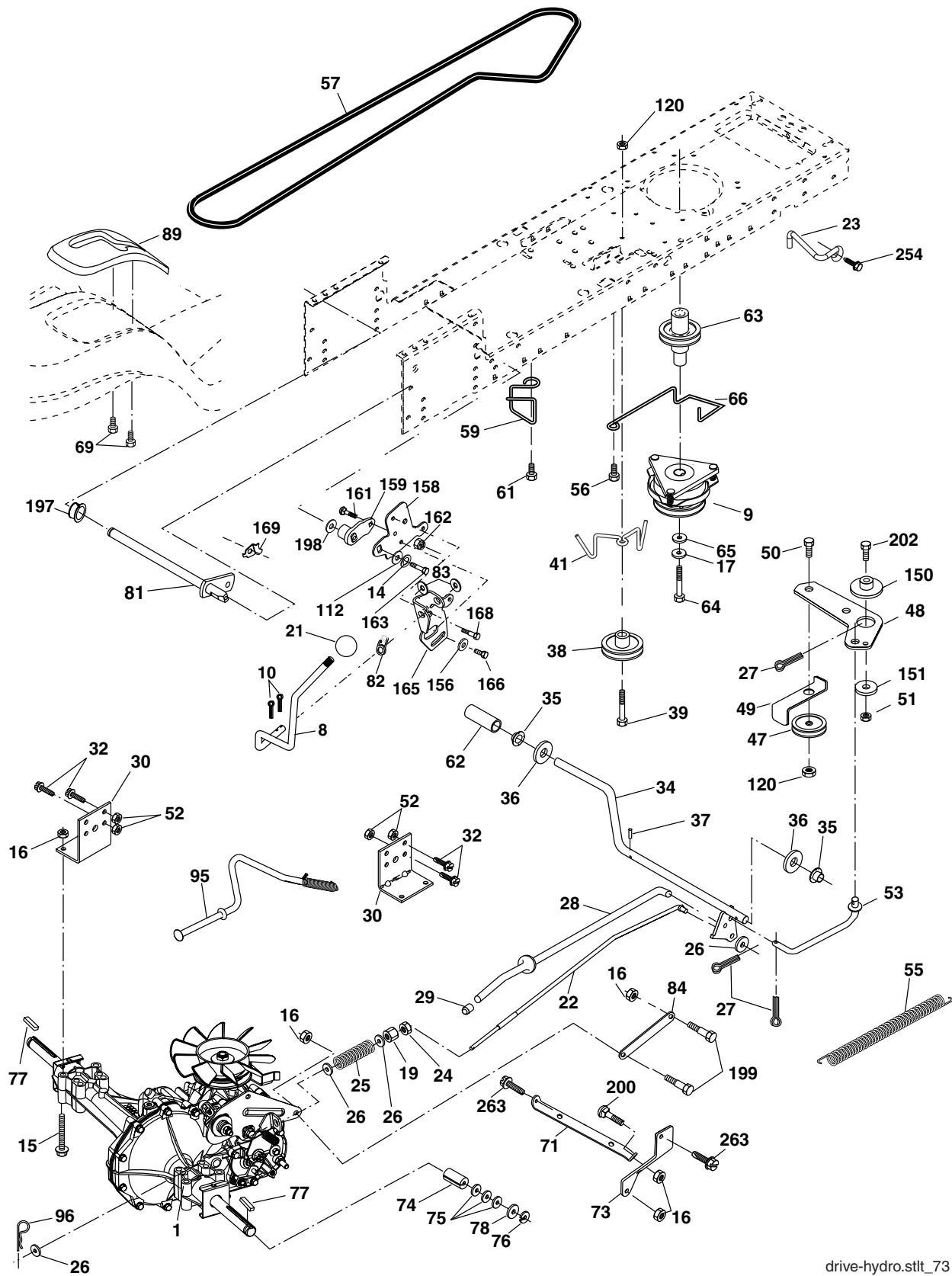

drive-hydro.stlt_73

REPAIR PARTS

TRACTOR-MODEL NUMBER YTH2448 (96013000700), PRODUCT NO. 960 13 00-07
DRIVE

KEY NO.	PART NO.	DESCRIPTION	KEY NO.	PART NO.	DESCRIPTION
1	-----	Transaxle (See Breakdown) Hydro Gear Model 314-0510	64	532 17 39-37	Bolt, Hex
8	532 19 25-02	Rod Shift	65	810 04 07-00	Washer Lock Hvy Hlcl Spr. 7/16
9	532 17 93-34	Clutch Electric	66	532 15 47-78	Keeper Belt Engine
10	876 02 04-16	Pin Cotter 1/8 x 1 CAD	69	532 14 24-32	Screw
14	810 04 04-00	Washer Lock Hvy. Helical	71	532 16 91-83	Strap Torque Lh Hydro
15	874 49 05-44	Bolt, Hex FLGHD 5/16-18 Gr. 5	73	532 16 91-82	Strap Torque Rh Hydro
16	873 80 05-00	Nut Lock Hex W/Ins 5/16-18 unc P	74	532 13 70-57	Spacer, Split
17	532 12 61-97	Washer 1-1/2 OD x 15/32 ID x 2.50	75	532 12 17-49	Washer 25/32 x 1-1/4 x 16 Ga.
19	873 80 06-00	Nut Lock Hex W/Wsh 3/8-16 unc	76	812 00 00-01	E-Ring
21	532 14 08-45	Knob	77	532 12 35-83	Key, Square
22	532 16 94-98	Rod, Brake Hydro	78	532 12 17-48	Washer 25/32 x 1-5/8 x 16 Ga.
23	532 19 07-36	Bracket Anti-Rotation	81	532 16 55-96	Shaft Asm. Cross
24	873 35 06-00	Nut Hex Jam 3/8-16	82	532 16 57-11	Spring Torsion
25	532 10 68-88	Spring, Brake Rod	83	819 17 12-16	Washer 17/32 x 3/4 x 16 Ga.
26	819 13 13-16	Washer	84	532 16 95-94	Link, Transaxle
27	876 02 04-12	Pin Cotter 1/8 x 3/4 CAD.	89	532 19 48-10	Console, Shift
28	532 17 57-65	Rod, Parking Brake	95	532 17 02-01	Control Asm Bypass Hydro
29	532 07 16-73	Cap, Parking Brake	96	532 12 47-88	Retainer Spring 1" Zinc/Cad
30	532 16 95-92	Bracket, Transaxle	112	819 09 12-10	Washer 9/32 x 3/4 x 10 Ga.
32	874 76 05-12	Bolt Hex Hd 5/16-18 unc x 3/4	120	873 90 06-00	Nut Lock Fig 3/8-16 unc
34	532 17 55-78	Shaft, Foot Pedal Nibbed	151	819 13 32-10	Washer 13/32 x 2 x 10 Ga.
35	532 12 01-83	Bearing, Nylon	150	532 17 54-56	Spacer Retainer
36	819 21 16-16	Washer 21/32 x 1 x 16 Ga.	156	532 16 60-02	Washer Srrted 5/16 ID x 1 x .125
37	532 12 49-63	Pin, Roll 3/16 x 1	158	532 16 55-89	Bracket Shift Mount
38	532 17 91-14	Pulley, Idler, Composite	159	532 18 39-00	Hub Shift
39	872 11 06-22	Bolt 3/8-16unc x 2-3/4	161	872 14 04-06	Bolt Rdhd Sqnk 1/4-20 x 3/4 Gr. 5
41	532 17 55-56	Keeper, Belt Retainer	162	873 68 04-00	Nut Crownlock 1/4-20 unc
47	532 12 77-83	Pulley, Idler, V-Groove	163	874 78 04-16	Bolt Hex Fin 1/4-20 unc x 1 Gr. 5
48	532 15 44-07	Bellcrank Clutch Grnd Drv STL	165	532 16 56-23	Bracket Pivot Lever
49	532 12 32-05	Retainer, Belt	166	817 49 05-10	Screw 5/16-18 x 5/8
50	872 11 06-12	Bolt Carr Sh 3/8-16 x 1-1/2 Gr.5	168	532 16 54-92	Bolt Shoulder 5/16-18 x .561
51	873 68 06-00	Nut Crownlock 3/8-16 unc	169	532 16 55-80	Plate Fastening LT
52	873 68 05-00	Nut Crownlock 5/16-18 unc	197	532 16 96-13	Nyliner Snap-In 5/8" ID
53	532 10 57-10	Link, Clutch	198	532 16 95-93	Washer Nyl 7/8" ID x .105"
55	532 10 57-09	Spring, Return, Clutch	199	532 16 96-12	Bolt Shoulder 5/16-18 unc
56	817 06 06-20	Screw 3/8-16 x 1.0	200	872 14 05-08	Bolt Rdhd Sqnk 5/16-18 unc x 1
57	532 14 02-94	V-Belt, Ground Drive	202	872 11 06-14	Bolt 3/8-16 x 1-3/4 Gr. 5
59	532 16 96-91	Keeper, Center Span	254	817 00 06-16	Screw 3/8-16 x 1
61	817 12 06-14	Screw 3/8-16 x 3/4	263	817 00 06-12	Screw 3/8-16 x .75
62	532 12 48-72	Cover, Pedal			
63	532 17 46-07	Pulley, Engine			

NOTE: All component dimensions give in U.S. inches.
1 inch = 25.4 mm

REPAIR PARTS

TRACTOR-MODEL NUMBER YTH2448 (96013000700), PRODUCT NO. 960 13 00-07
STEERING ASSEMBLY

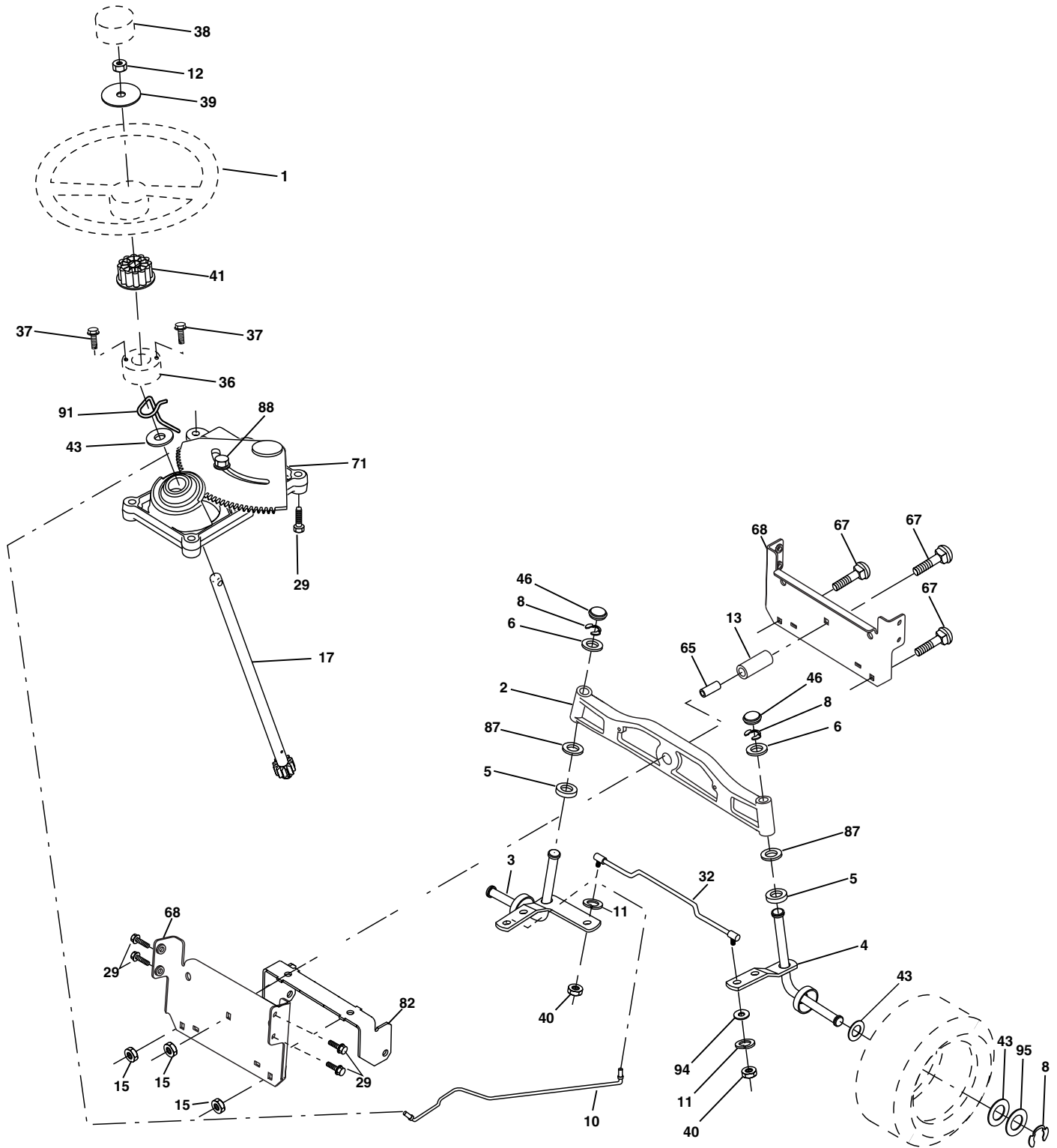

steering_pl.lt_54

REPAIR PARTS

TRACTOR-MODEL NUMBER YTH2448 (96013000700), PRODUCT NO. 960 13 00-07
STEERING ASSEMBLY

KEY NO.	PART NO.	DESCRIPTION
1	532 19 36-51	Wheel Steering
2	532 18 47-06	Axle
3	532 16 98-40	Spindle Asm LH
4	532 16 98-39	Spindle Asm RH
5	532 12 49-31	Bearing Race Thrust Harden
6	532 12 17-48	Washer 25/32 x 1-5/8 x 16 Ga.
8	812 00 00-29	Ring Klip #t5304-75
10	532 17 51-21	Link Drag
11	810 04 06-00	Washer Lock Hvy Hlcl Spr 3/8
12	873 94 08-00	Nut Hex Jam Toplock 1/2-20 unf
13	532 13 65-18	Spacer Brg Axle Front
15	532 14 52-12	Nut Hex Flange Lock
17	532 17 78-83	Shaft Asm Strg
29	817 00 06-12	Screw 3/8-16 x 3/4
32	532 18 05-80	Rod Tie
36	532 15 51-05	Bushing Strg
37	532 15 29-27	Screw TT #32.5 x 5 x 3/8 Flange
38	532 19 36-52	Cap Wheel Steer
40	873 54 06-00	Nut Crownlock 3/8-24
41	532 18 67-37	Adaptor Wheel Strg
43	532 12 17-49	Washer 25/32 x 1 1/4 x 16 Ga.
46	532 12 12-32	Cap Spindle Fr Top Blk
65	532 16 03-67	Spacer Brace Axle
67	872 11 06-18	Bolt Rdhd Sqn 3/8-16 x 2-1/4
68	532 16 98-27	Brace, Axle
71	532 17 51-46	Steering Asm.
72	819 18 38-12	Washer 9/16 ID x 2-3/8 OD 12 Ga.
82	532 16 98-35	Bracket Susp Chassis Front
87	532 17 39-66	Washer Flat .781 x 1-1/2 x .14
88	532 17 51-18	Bolt Shoulder 7/16-20 unc
91	532 17 55-53	Clip
94	819 12 14-14	Washer 3/8 x 7/8 x 14 Ga.
95	532 18 89-67	Washer Hardened

NOTE: All component dimensions given in U.S. inches.
1 inch = 25.4 mm.

REPAIR PARTS

TRACTOR-MODEL NUMBER YTH2448 (96013000700), PRODUCT NO. 960 13 00-07
ENGINE

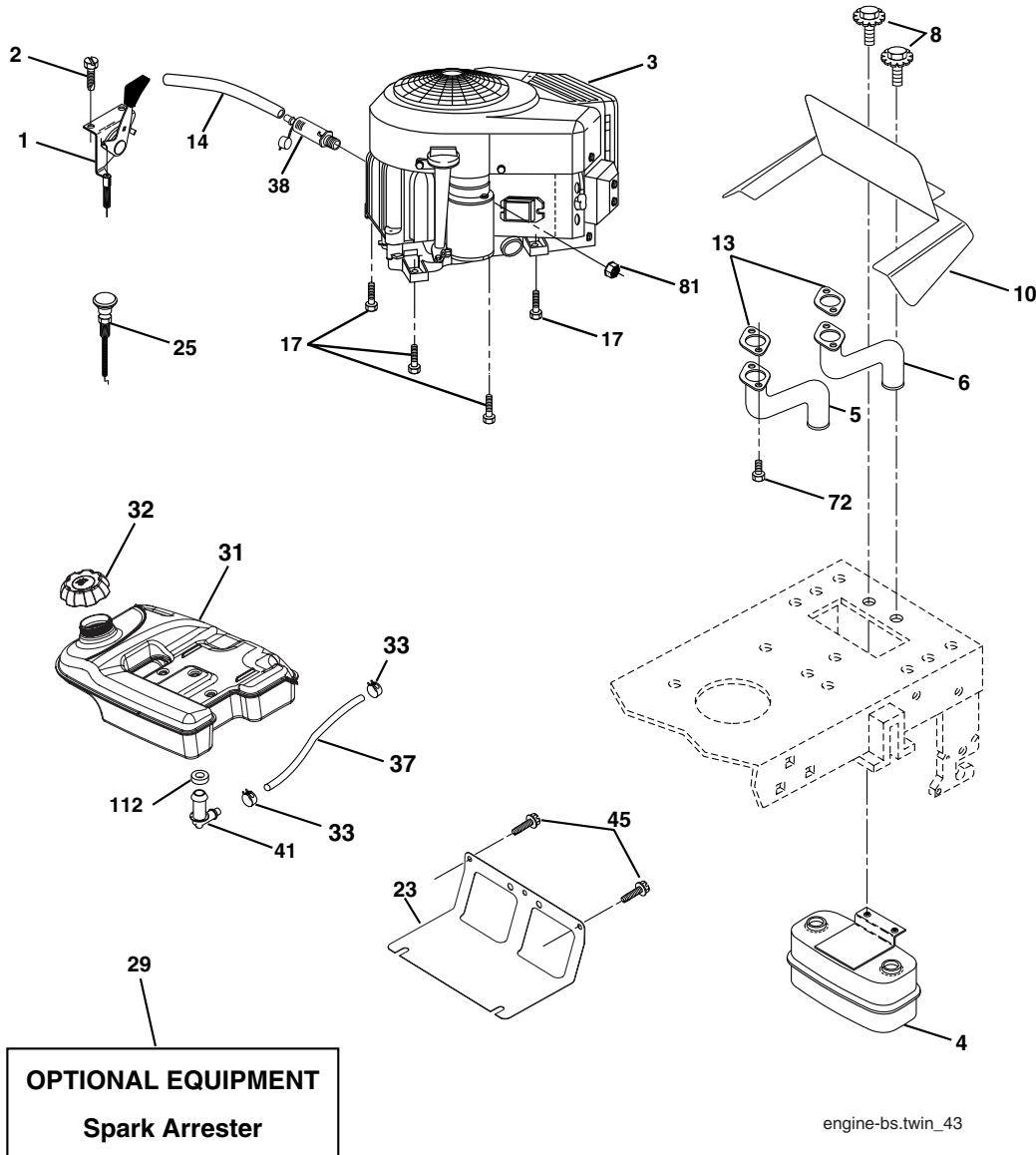

KEY NO.	PART NO.	DESCRIPTION
1	532 19 04-54	Control Throttle
2	817 72 04-08	Screw 1/4-20 x 1/2
3	-----	Engine, Briggs Model 446677 (Order parts from engine mfg.)
4	532 14 97-23	Muffler Asm Twin Lo-Tone
5	532 15 99-55	Pipe Exhaust LH
6	532 16 05-89	Pipe Exhaust RH
8	532 17 18-77	Bolt 5/16-18 unc x 3/4 w/Sems
10	532 16 27-97	Shield
13	532 16 53-91	Muffler Gasket
14	532 14 84-56	Tube Drain Oil Easy
17	817 06 06-24	Screw Thdrol 3/8-16 x 1-1/2
23	532 16 98-37	Shield Heat
25	532 13 27-82	Choke Control
29	532 13 71-80	Kit Spark Arrester (Flat Scrn)
31	532 17 90-22	Tank Fuel 4.0 Rear
32	532 18 18-03	Cap Asm Fuel
33	532 12 34-87	Clamp Hose Black

KEY NO.	PART NO.	DESCRIPTION
37	532 14 21-58	Line Fuel
38	532 18 16-54	Plug Drain Oil
41	532 13 92-77	Stem Tank Fuel
45	917 00 06-12	Screw Hexwsh Thdr 3/8-16 x 3/4
72	532 18 39-06	Screw Socket Head 5/16-18 x 1
112	532 12 49-52	Bushing
116	532 18 43-62	Nut Hex Flange Toplock M8-1.25

NOTE: All component dimensions given in U.S. inches
1 inch = 25.4 mm

For engine service and replacement parts, call the toll free number for your engine manufacturer listed below:

Briggs & Stratton	1-800-233-3723
Kohler Co.	1-800-544-2444
Tecumseh Products	1-800-558-5402
Honda Engines	1-800-426-7701
Kawasaki	1-949-460-5688

REPAIR PARTS

TRACTOR-MODEL NUMBER YTH2448 (96013000700), PRODUCT NO. 960 13 00-07
SEAT ASSEMBLY

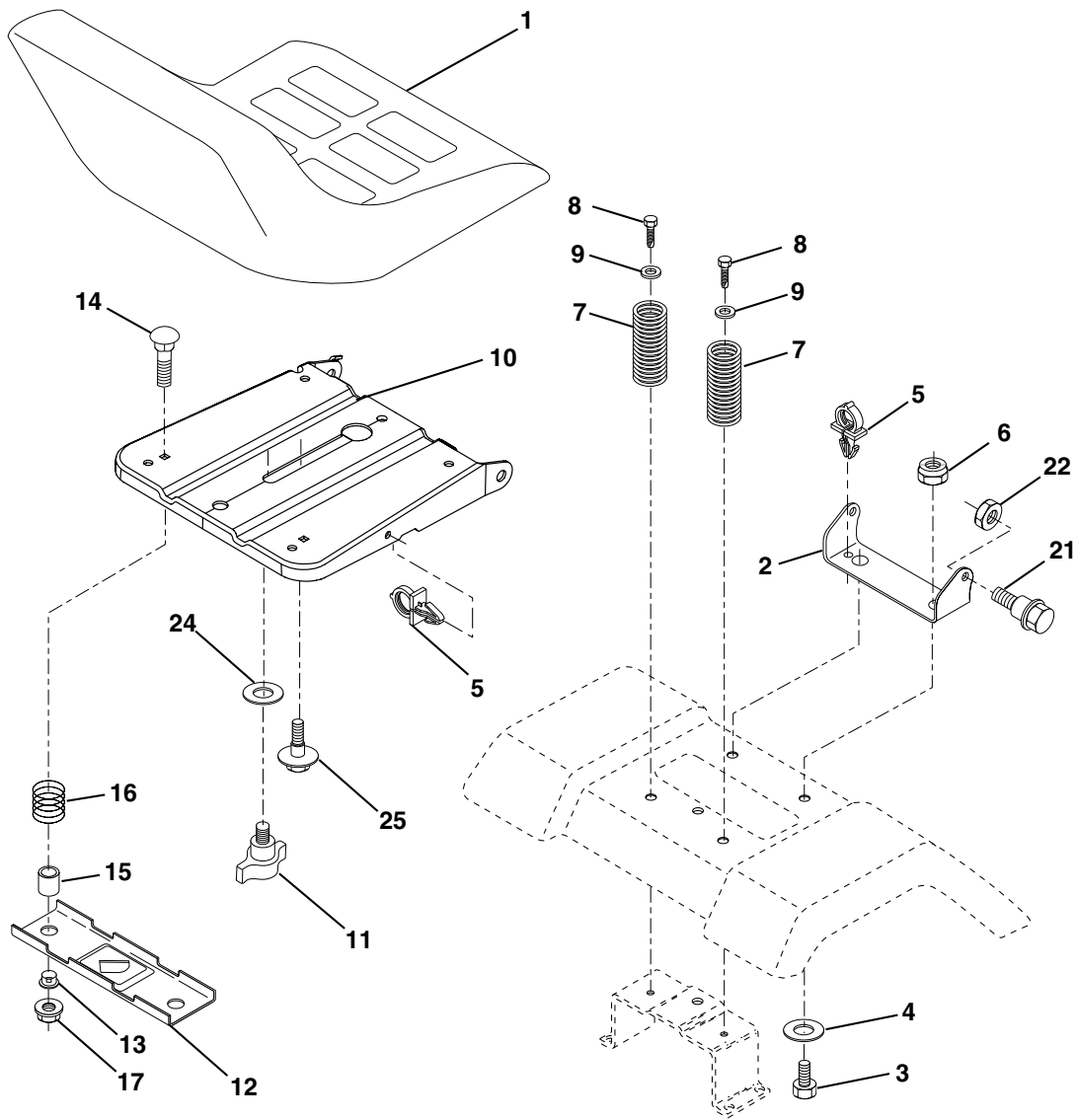

seat_lt.knob_13

KEY NO.	PART NO.	DESCRIPTION
1	532 18 87-15	Seat
2	532 14 05-51	Bracket Pivot Seat 8 720
3	871 11 06-16	Bolt Fin Hex 3/8-16 unc x 1
4	819 13 16-10	Washer Flat 13/32 x 1 x 10 Ga.
5	532 14 50-06	Clip Push-In
6	873 80 06-00	Nut Hex w/Ins. 3/8-16 unc
7	532 12 41-81	Spring Seat Cprsn 2 250 Blk Zi
8	817 00 06-16	Screw 3/8-16 x 1
9	819 13 16-14	Washer 13/32 x 1 x 14 Ga.
10	532 18 24-93	Pan Seat
11	532 16 63-69	Knob Seat Adj. Wingnut
12	532 17 46-48	Bracket Mounting Switch

KEY NO.	PART NO.	DESCRIPTION
13	532 12 12-48	Bushing Snap Blk Nyl 50 Id
14	872 05 04-12	Bolt Rdhd Sqnk 1/4-20 x 1-1/2
15	532 12 12-49	Spacer Split
16	532 12 37-40	Spring Cprsn
17	532 12 39-76	Nut Lock 1/4 Lge Flg Gr. 5 Zinc
21	532 17 18-52	Bolt Shoulder 5/16-18 unc
22	873 80 05-00	Nut Hex Lock W/Ins 5/16-18
24	819 17 19-12	Washer 17/32 x 1-3/16 x 12 Ga.
25	532 12 70-18	Bolt Shoulder 5/16-18 x 62

NOTE: All component dimensions given in U.S. inches.
1 inch = 25.4 mm

REPAIR PARTS

TRACTOR-MODEL NUMBER YTH2448 (96013000700), PRODUCT NO. 960 13 00-07
DECALS

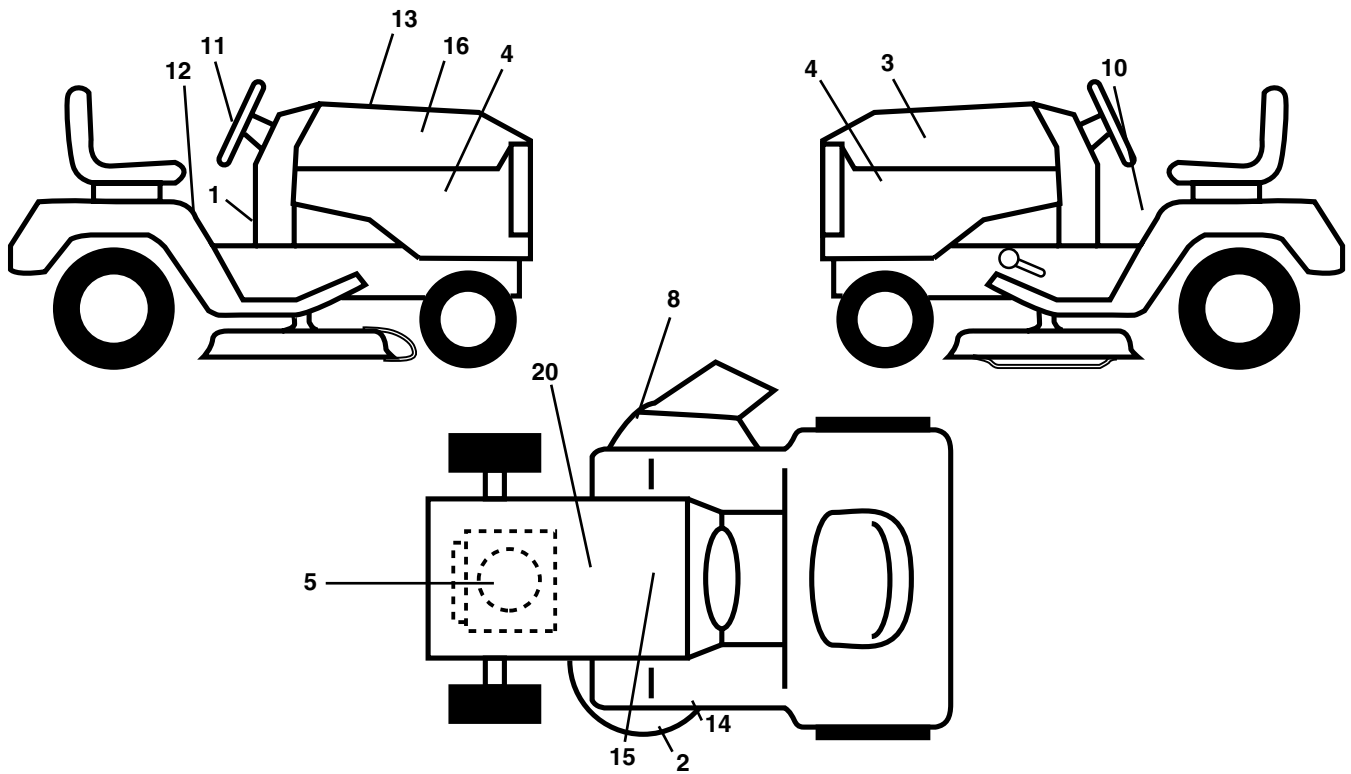

KEY NO.	PART NO.	DESCRIPTION
1	532 18 92-43	Decal Dash
2	532 17 84-82	Decal Heavy Duty
3	532 18 89-19	Decal Hood LH
4	532 19 54-87	Decal Side Panel
5	532 19 55-49	Decal Engine
8	532 17 05-63	Decal Warning Mower
10	532 15 71-40	Decal Fender Danger E/F
11	532 18 89-25	Decal Ins Strg Whl
12	532 19 39-39	Decal Fender Oper
13	532 18 09-41	Decal Hood Cust Resp.
14	532 17 52-91	Decal V-Belt Schematic

KEY NO.	PART NO.	DESCRIPTION
15	532 19 54-59	Decal Replacement
16	532 18 89-18	Decal Hood Rh
20	532 14 50-05	Decal Bat Dan/Psn
--	532 16 69-60	Decal By Pass
--	532 18 82-52	Pad Footrest Lh
--	532 18 82-53	Pad Footrest Rh
--	532 13 83-11	Decal Height Adjustment
--	532 19 54-23	Manual, Owners English
--	532 19 54-24	Manual, Owners French

WHEELS & TIRES

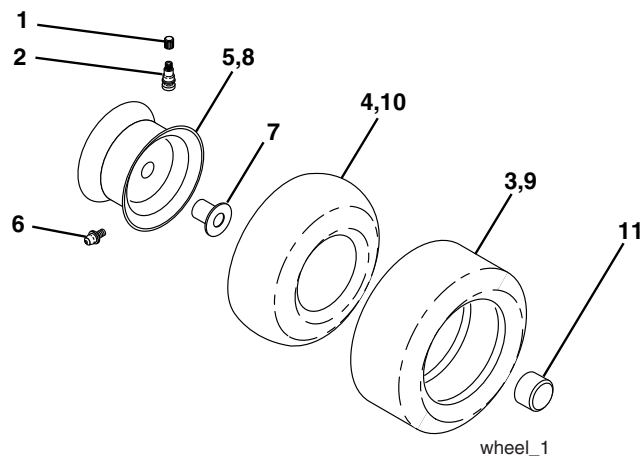

KEY NO.	PART NO.	DESCRIPTION
1	532 05 91-92	Cap Valve Tire
2	532 06 51-39	Stem Valve
3	532 10 62-22	Tire F T 15 x 6 0 - 6 Service
4	532 05 99-04	Tube Front (Service Item Only)
5	532 13 83-36	Rim Asm 6"front Service
6	532 12 49-57	Fitting Grease (Front Wheel Only)
7	532 12 49-59	Bearing Flange (Front Wheel Only)
8	532 13 83-37	Rim Asm 8"rear Service
9	532 13 84-68	Tire R T 20 x 8-8 C Service
10	532 12 49-26	Tube Rear (Service Item Only)
11	532 17 50-39	Cap Axle 1 50 x 1 00
--	532 14 43-34	Sealant, Tire (10 oz. Tube)

NOTE: All component dimensions given in U.S. inches
1 inch = 25.4 mm

REPAIR PARTS

TRACTOR-MODEL NUMBER YTH2448 (96013000700), PRODUCT NO. 960 13 00-07
MOWER LIFT

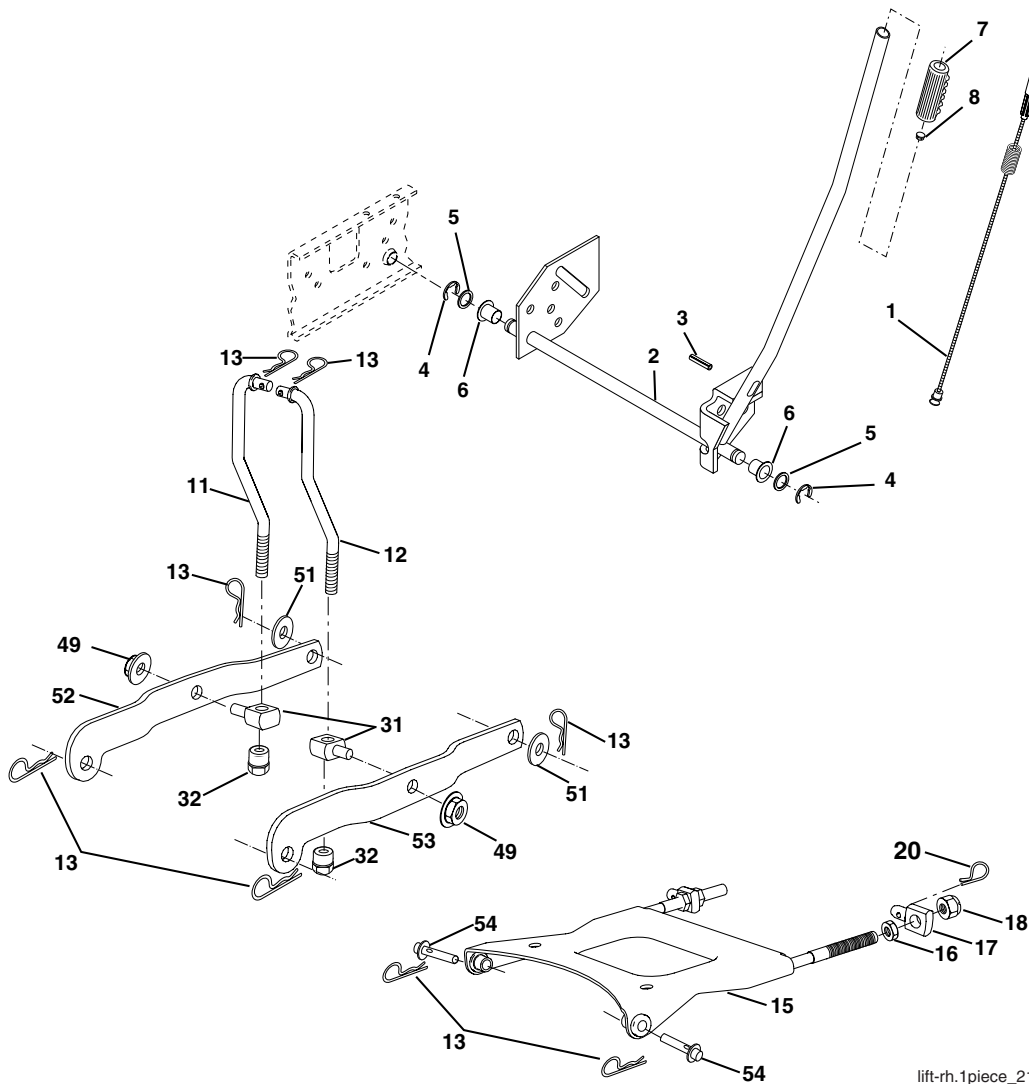

lift-rh.1piece_21

KEY NO.	PART NO.	DESCRIPTION
1	532 15 94-60	Plunger Asm.
2	532 15 94-71	Shaft Asm Lift RH w/Inf
3	532 10 57-67	Pin Groove
4	812 00 00-02	E Ring #5133-62
5	819 21 16-21	Washer 21/32 x 1 x 21 Ga.
6	532 12 01-83	Bearing Nylon Blk 629 Id
7	532 12 56-31	Grip Handle
8	532 12 45-26	Button Plunger
11	532 17 53-70	Link Lift LH
12	532 17 53-71	Link Lift RH
13	532 12 46-70	Retainer Spring
15	532 17 55-62	Plate Asm. Suspension Front
16	873 35 08-00	Nut Jam Hex 1/2-13 unc

KEY NO.	PART NO.	DESCRIPTION
17	532 17 56-89	Trunnion Front Susp.
18	873 80 08-00	Nut Lock w/Wsh 1/2-13 unc
20	532 16 35-52	Retainer Spring
31	532 17 62-05	Trunnion Susp. Arm
32	532 17 59-94	Nut Lift Link 7/16-20
49	532 14 52-12	Nut Hex Flange Lock
51	819 17 14-16	Washer 17/32 x 7/8 x 16 Ga.
52	532 17 53-78	Arm Susp. Rear LH
53	532 17 58-02	Arm Susp. Rear RH
54	532 17 55-60	Pin

NOTE: All component dimensions given in U.S. inches
1 inch = 25.4 mm

REPAIR PARTS

TRACTOR-MODEL NUMBER YTH2448 (96013000700), PRODUCT NO. 960 13 00-07
MOWER DECK

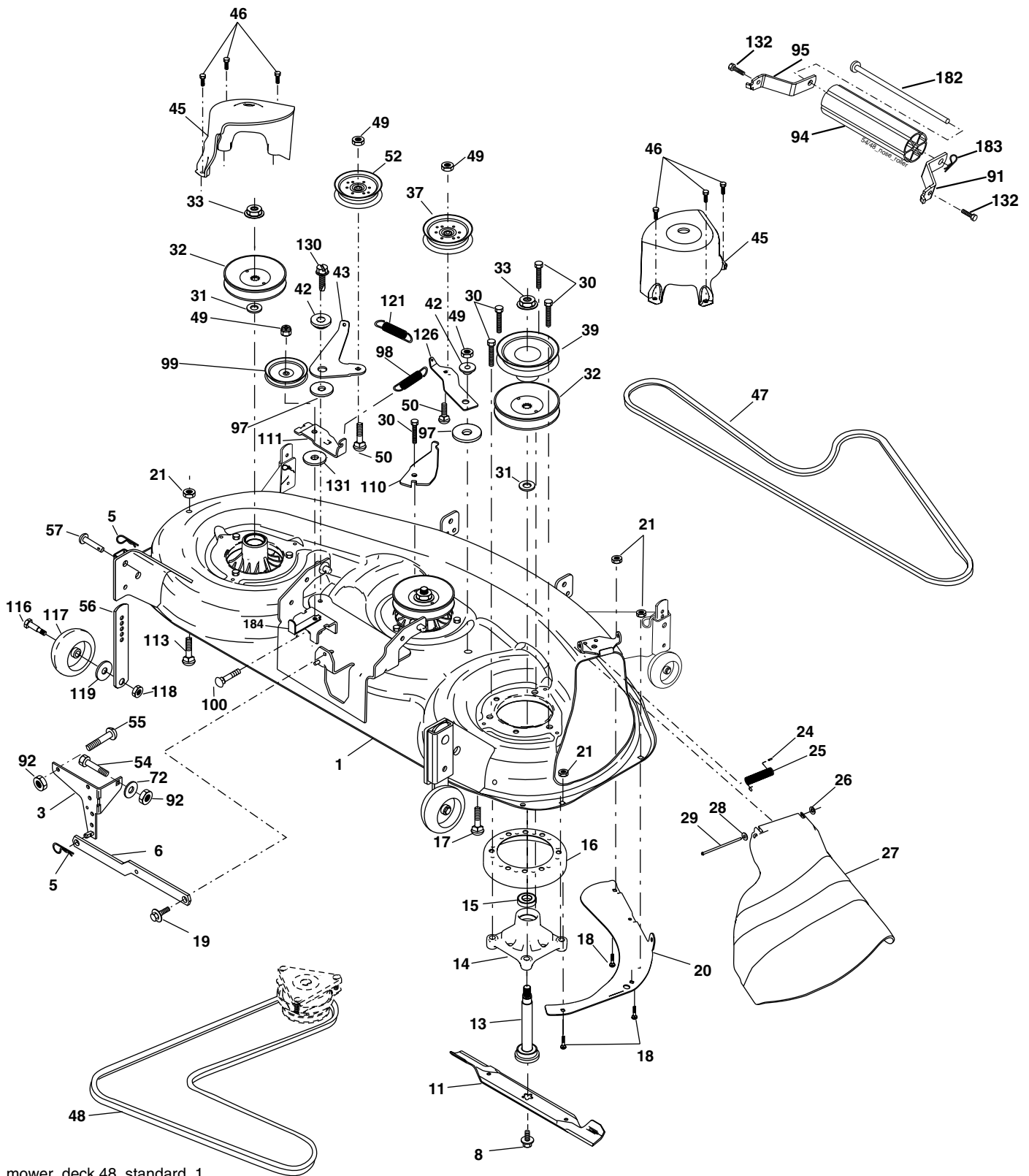

mower_deck.48_standard_1

REPAIR PARTS

TRACTOR-MODEL NUMBER YTH2448 (96013000700), PRODUCT NO. 960 13 00-07
MOWER DECK

KEY NO.	PART NO.	DESCRIPTION	KEY NO.	PART NO.	DESCRIPTION
1	532 18 18-48	Deck Weldment Mower 48	52	532 17 58-20	Pulley Idler Flat
3	532 13 80-17	Bracket Asm., Sway Bar	54	874 78 06-16	Bolt Fin Hex 3/8-16 x 1
5	532 12 46-70	Retainer Spring	55	872 14 06-08	Bolt Carriage Sqkn. 3/8-16 x 1
6	532 17 80-24	Arm, Suspension, Rear Sway Bar Deck	56	532 15 59-86	Bar Pnt Adj.
8	532 17 43-65	Bolt 7/16 Asm. Blade (The following blades are available)	57	532 15 69-41	Pin Head Rivet
11	532 18 00-54	Blade, 48" Hi-Lift (For bagging and discharging)	72	819 13 13-12	Washer 13/32 x 13/16 x 12 Ga.
--	532 17 39-21	Blade, 48" Mulching (For mulching mowers only)	91	532 18 05-35	Bracket, Asm Noseroller, RH
13	532 17 43-60	Shaft Asm. w/Lower Bearing	92	873 80 06-00	Nut Lock Hex 3/8-16
14	532 17 43-58	Mandrel Asm. Housing	94	532 17 60-66	Noseroller
15	532 11 04-85	Bearing, Ball, Mandrel	95	532 18 05-34	Bracket, Asm Noseroller LH
16	532 17 44-93	Stripper Mandrel Deck	97	532 17 85-15	Washer Hardened
17	872 11 06-10	Bolt RDHD Sq Neck 3/8-16 x 1.25	98	532 17 94-79	Spring Primary Drive
18	872 14 05-05	Bolt, Carriage 5/16-18 x 5/8	99	532 18 99-93	Pulley Idler"V"
19	532 13 28-27	Bolt, Hex Hd, Shoulder 5/16-18	100	872 11 06-16	Bolt RDHD Sqkn 3/8-16 unc x 2
20	532 17 43-78	Baffle, Vortex Mower	110	532 17 50-16	Arm Spring Break
21	873 68 05-00	Nut, Crownlock 5/16-18 unc	111	532 17 46-10	Arm Spring Field Tension
24	532 10 53-04	Cap, Sleeve	113	872 11 05-06	Bolt 5/16-18 x 3/4
25	532 17 81-02	Spring, Torsion	116	532 19 34-06	Bolt, Shoulder
26	532 11 04-52	Nut, Push	117	532 17 48-73	Gauge Wheel
27	532 18 17-07	Deflector Shield	118	873 93 06-00	Nut, Centerlock 3/8-16 unc
28	819 11 10-16	Washer 11/32 x 5/8 x 16 Ga.	119	819 12 14-14	Washer 3/8 x 7/8 x 14 Ga.
29	532 13 14-91	Rod, Hinge	121	532 17 43-71	Spring Secondary Drive
30	532 17 39-84	Screw, Thdroll Washer Head	126	532 17 43-72	Arm, Idler, Primary Deck
31	532 18 76-90	Washer, Spacer	130	817 00 06-16	Screw 3/8-16 x 1.0
32	532 17 34-36	Pulley, Mandrel	131	819 13 16-06	Washer 13/32 x 1.00 x 6 Ga.
33	532 17 83-42	Nut, Flg. Top Lock Cntr. 9/16	132	817 00 06-12	Screw 3/8-16 x .75
37	532 17 79-68	Pulley, Idler, Flat	182	532 17 91-27	Rod Roller Nose
39	532 17 43-75	Pulley, Idler, Driven	183	532 16 35-52	Retainer Spring
42	532 12 20-52	Spacer, Retainer	184	532 17 39-79	Keeper Belt Idler
43	532 17 43-73	Arm, Idler Secondary	--	532 17 43-56	Mandrel Asm. Service (Includes Key Nos. 13-15 and 33)
45	532 18 08-06	Cover, Mandrel Deck	--	532 18 99-06	Replacement Mower, Complete (Std. Deck - Order separately nose roller components key nos. 91, 94, 95, 132, 182, and 183)
46	532 13 77-29	Screw, Thdroll. 1/4-20 x 5/8			
47	532 18 08-08	V-Belt, Mower, Secondary			
48	532 17 43-68	V-Belt, Mower, Primary			
49	873 90 06-00	Nut, Lock 3/8-16 unc			
50	872 11 06-12	Bolt, Carr. 3/8-16 x 1-1/2 Gr. 5			

NOTE: All component dimensions given in U.S. inches
1 inch = 25.4 mm