

# Repair Parts

RIDGID parts are available on-line at [www.ridgidparts.com](http://www.ridgidparts.com)

## WARNING

### SERVICING OF DOUBLE-INSULATED WET/DRY VAC

In a double-insulated Wet/Dry Vac, two systems of insulation are provided instead of grounding. No grounding means is provided on a double-insulated appliance, nor should a means for grounding be added. Servicing a double-insulated Wet/Dry Vac requires extreme care and knowledge of the system, and should be done only by qualified service personnel. Replacement parts for a double-insulated Wet/Dry Vac must be identical to the parts they replace. Your double-insulated Wet/Dry Vac is marked with the words "DOUBLE INSULATED" and the symbol  (square within a square) may also be marked on the appliances.

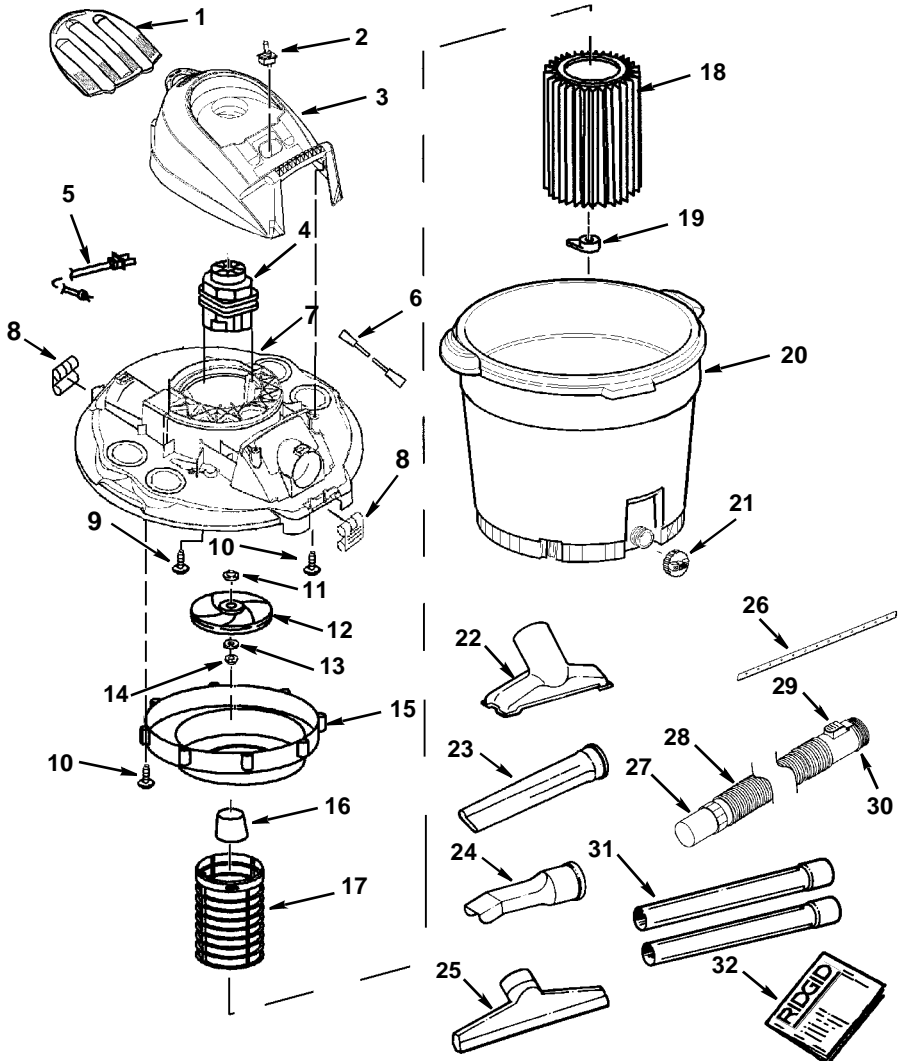

# Repair Parts

---

## 16 Gallon Contractor Wet/Dry Vac Model Number WD17350

RIDGID parts are available on-line at [www.ridgidparts.com](http://www.ridgidparts.com)

Always order by Part Number - Not by Key Number

Key No.	Part No.	Description
1	828830	Cap Trim
2	813213	Toggle Switch
3	828829-1	Motor Cover
4	828986	Motor Asm
5	829718-2	Cord Asm
6	819260-2	Lead Asm
7	828831-1	Lid
8	826387	Drum Latch
9	820563-5	Screw, Pan Hd. Serr Ty "AB" 10 x 1-1/4
10	820563-4	Screw, Pan Hd. Serr Ty "AB" 10 x 3/4
11	818961	Spacer
12	818413	Blower Wheel
13	15534-1	Washer
14	826817	Nut Hex Flange 5/16-18
15	829692	Collector Asm
16	509488	Float
17	823201-1	Filter Cage
18	VF5000	† Filter- 2 Stage
19	73316	Filter Nut
20	826331-2	Dust Drum
21	825881-2	Drain Cap
22	VT2509	† Utility Nozzle
23	VT2502	† Crevice Nozzle
24	VT2503	† Car Nozzle
25	VT2510	† Wet Nozzle (Includes Squeegee)
26	822256	Squeegee
27	815096	Adapter Hose
28	826356-1	Hose Asm (Includes Adapter, End, & Spring Tab)
29	826355-1	Spring Tab
30	826354	End Hose Interlock
31	VT2508	† Extension Wands
32	SP6437	Owners Manual

\* Standard Hardware Item - May be purchased locally

† These replacement parts are available where you purchased your vac.

# Repair Parts

## Parts List for Vac Cart

RIDGID parts are available on-line at [www.ridgidparts.com](http://www.ridgidparts.com)

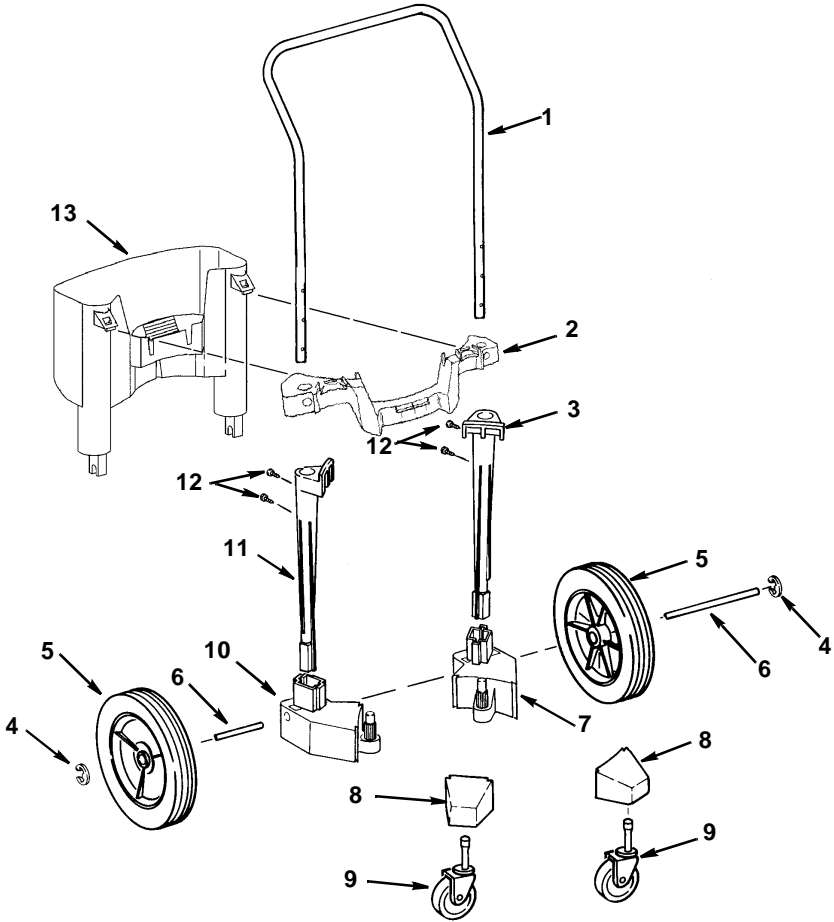

Always order by Part Number - Not by Key Number

Key No	Part No.	Description
1	818438-1	Handle
2	828844	Bracket, Handle
3	818435	Left Leg
4	805641-4	* Ring, Retaining 1/2"
5	809862-1	10" Wheel
6	818431-1	Axle
7	818433	Cradle, Left
8	818439	Caster Foot

Key No	Part No.	Description
9	819429	Caster
10	818434	Cradle, Right
11	818436	Right Leg
12	806742-5	Screw TY AB #10 x 3/4
13	828845	Tote
—	508134	Bag of Loose Parts (Not Illustrated)

\* Standard Hardware Item - May be purchased locally