

## ELECTRIC TOOL PARTS LIST

■ SCREW DRIVER  
Model W 6V1

1990 · 12 · 21  
(E5)

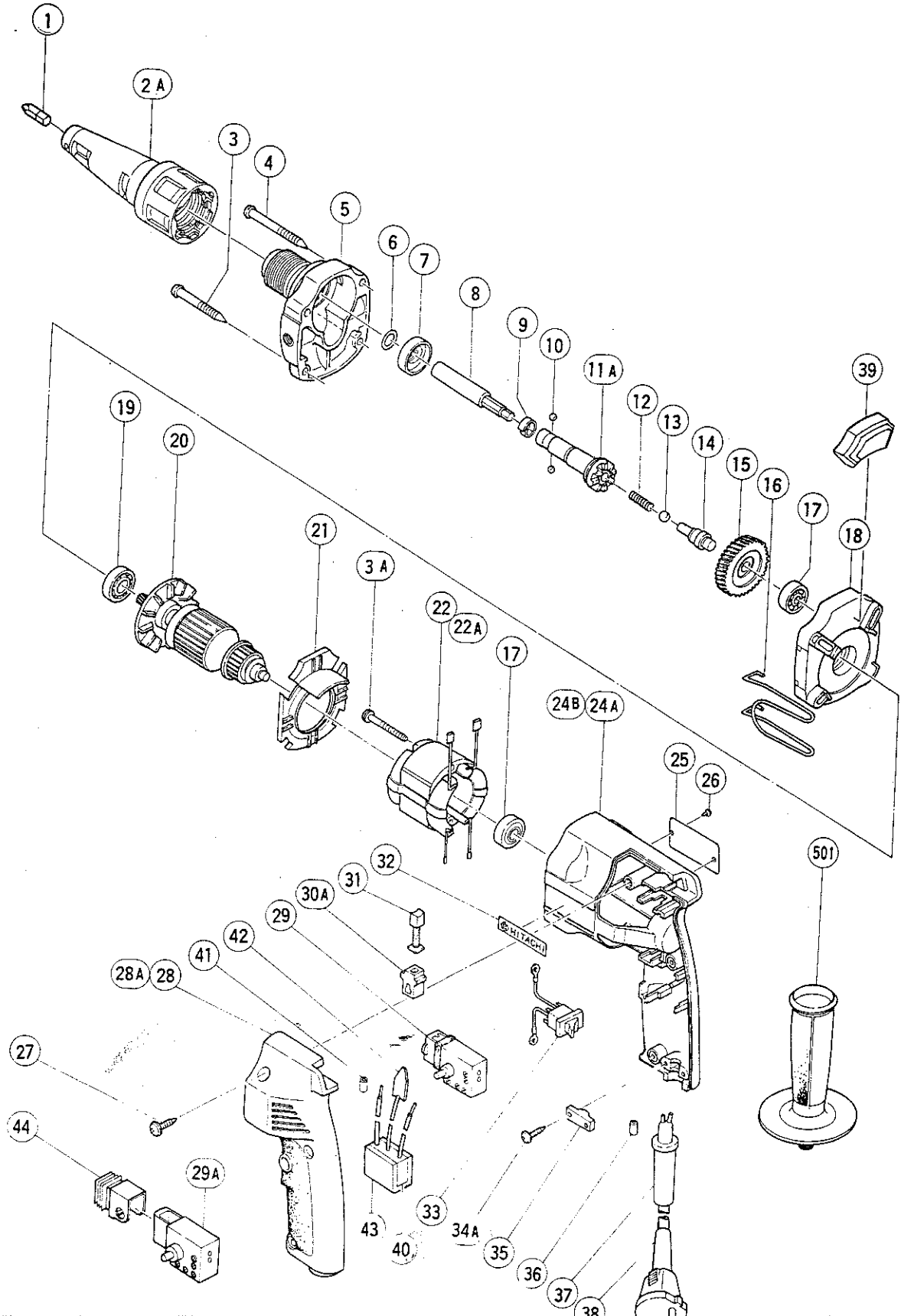

## PARTS

W 6V1

ITEM NO.	CODE NO.	DESCRIPTION	NO. USED	REMARKS
1	971-511Z	+ DRIVER BIT (A) NO.2 25L	1	
2A	982-555Z	LOCATOR (A)	1	
3	950-514	TAPPING SCREW D4X40	2	
3A	992-630	TAPPING SCREW (W/SP. WASHER) D4X40	2	
4	950-515	TAPPING SCREW D4X50	2	
*	5	982-562Z	GEAR COVER ASS'Y	1 INCLUD.6
*	5	982-561	GEAR COVER ASS'Y	1 INCLUD.6 FOR USA,CAN
	6	982-564	O - RING (1AP - 15)	1
	7	971-468	FRINGER (A)	1
	8	982-554Z	MAGNETIC BIT HOLDER	1
	9	872-573	SET RING	1
	10	959-148	STEEL BALL D3.175 (10 PCS.)	2
	11A	982-572	SOCKET (A)	1
	12	943-523	SPRING (A)	1
	13	959-154	STEEL BALL D5.556 (10 PCS.)	1
	14	982-552	GEAR SHAFT	1
	15	982-571	GEAR (A)	1
	16	950-511	HOOK	1
	17	608-VVM	BALL BEARING 608VVMC2EPS2L	2
	18	998-500	INNER COVER	1
	19	609-VVM	BALL BEARING 609VVMC2PS2S	1
*	20	360-048U	ARMATURE ASS'Y 110V - 115V	1 INCLUD.17,19 FOR CAN
*	20	360-113C	ARMATURE 110V - 127V	1
*	20	360-113E	ARMATURE 220V - 230V	1
*	20	360-113F	ARMATURE 240V	1
*	20	360-113G	ARMATURE 220V	1 FOR ITA,HOL,DEN
*	20	360-113H	ARMATURE 240V	1 FOR GBR
*	20	360-113J	ARMATURE 110V	1 FOR GBR
*	20	360-175	ARMATURE 100V	1 FOR KOR
	21	950-504	FAN GUIDE	1
*	22	340-099C	STATOR 110V - 115V	1
*	22	340-099D	STATOR 120V - 127V	1
*	22	340-099F	STATOR 240V	1
*	22	340-099H	STATOR 240V	1 FOR GBR
*	22	340-099J	STATOR 110V	1 FOR GBR
*	22	340-099K	STATOR 220V - 230V	1
*	22	340-135	STATOR 100V	1 FOR KOR
*	22	340-150G	STATOR (B) 220V	1 FOR HOL,DEN,ITA
*	22A	340-099M	STATOR 220V	1 FOR FRG
*	24A	991-880	HOUSING	1 (TILL 12.1987 FOR USA ONLY)
*	24B	995-360	HOUSING	1 SINCE 1.1988 FOR USA
	25		NAME PLATE	1
*	26	932-642	RIVET D2.5X2.8	2 FOR CAN
	27	982-095	TAPPING SCREW (W/WASHER) D4X20	3
*	28	991-885	HANDLE COVER	1 (TILL 12.1987 FOR USA ONLY)
*	28A	995-361	HANDLE COVER	1 SINCE 1.1988 FOR USA
*	29	982-559Z	SWITCH 220V - 240V (2P PILLAR TYPE)	1
*	29	985-347	SWITCH 100V - 127V (2P PILLAR TYPE) W/LOCK	1 (TILL 12.1987 FOR USA ONLY)
*	29A	998-185	SWITCH (G) (2P PILLAR TYPE) W/LOCK	1 SINCE 1.1988 FOR USA
	30A	930-483	BRUSH HOLDER	2
*	31	999-041	CARBON BRUSH (1 PAIR)	1 FOR USA,CAN

**PARTS**

W 6V1

ITEM NO.	CODE NO.	DESCRIPTION	NO. USED	REMARKS
* 31	999-080	CARBON BRUSH (AUTO STOP TYPE) (1 PAIR)	1	FOR USA,CAN
* 31	999-041	CARBON BRUSH (1 PAIR)	2	
32	950-565	HITACHI LABEL	1	
* 33	992-636	REVERSING SWITCH	1	
* 33	995-350	REVERSING SWITCH	1	FOR FRG,GBR,ITA,DEN,HOL
34A	984-750	TAPPING SCREW (W/FLANGE) D4X16	2	
35	937-631	CORD CLIP	1	
36	981-373	TUBE (D)	2	FOR CORD
* 37	930-487	CORD ARMOR D8.2	1	
* 37	980-193	CORD ARMOR D10.2	1	
* 38	500-212Z	CORD	1	(CORD ARMOR D8.2)
* 38	500-223Z	CORD	1	(CORD ARMOR D10.2)FOR SIN,KUW
* 38	500-226Z	CORD	1	(CORD ARMOR D10.2)FOR OCEANIA
* 38	500-231Z	CORD	1	(CORD ARMOR D8.2)FOR GBR
* 38	500-245Z	CORD	1	(CORD ARMOR D10.2)FOR SYR
* 38	500-247Z	CORD	1	(CORD ARMOR D10.2)FOR DEN
* 38	500-409Z	CORD	1	(CORD ARMOR D8.2)FOR EUROPE,INA,SUR
* 38	500-415Z	CORD	1	(CORD ARMOR D8.2)FOR USA,CAN
* 38	930-051	CORD	1	(CORD ARMOR D10.2)FOR KOR
* 39	971-526Z	WIND COVER	1	FOR FRG
* 40	971-828	NOISE SUPPRESSOR	1	FOR ITA,DEN
* 40	994-273	NOISE SUPPRESSOR	1	FOR FRG,GBR,HOL
* 41	981-373	TUBE (D)	1	FOR NOISE SUPPRESSOR
* 42	992-635	EARTH TERMINAL	1	FOR NOISE SUPPRESSOR
* 43	930-153	SUPPORT (B)	1	FOR NOISE SUPPRESSOR
* 44	995-362	SWITCH RUBBER COVER	1	FOR USA

**STANDARD ACCESSORIES**

ITEM NO.	CODE NO.	DESCRIPTION	NO. USED	REMARKS
* 501	994-322	SIDE HANDLE	1	EXCEPT FOR USA,CAN