

RYOBI 12 in. (305 mm) MITER SAW – MODEL NO. TS1551

FIGURE A

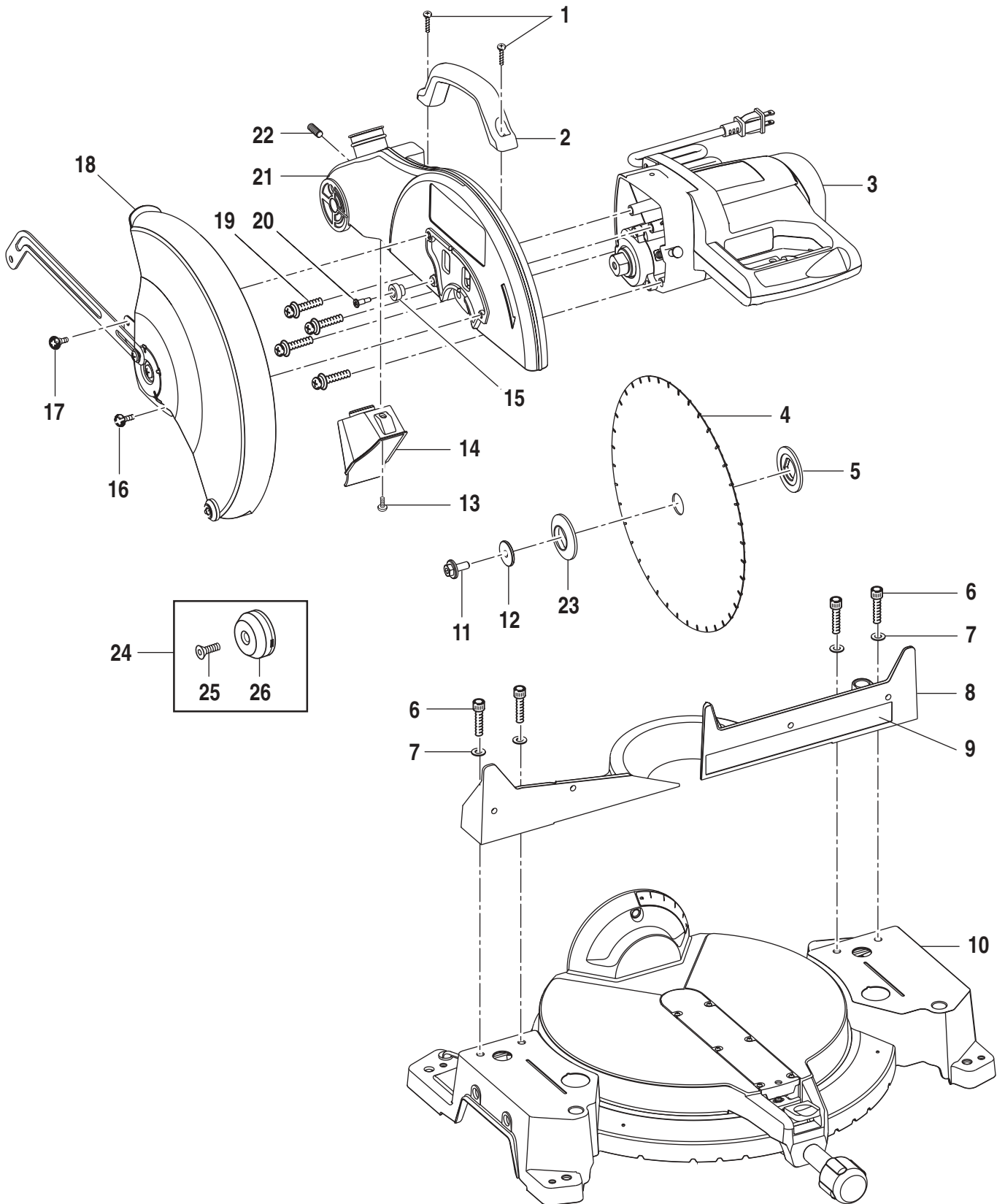

RYOBI 12 in. (305 mm) MITER SAW – MODEL NO. TS1551

The model number will be found on a plate attached to the motor housing. Always mention the model number in all correspondence regarding your **Miter Saw** or when ordering repair parts.

PARTS LIST FOR FIGURE A

KEY NO.	PART NUMBER	DESCRIPTION	QTY.
1	020102-005	SCREW	2
2	303513-000	HANDLE	1
3	T990054-001	MOTOR ASSEMBLY W/WARNING AND DATA LABELS (SEE FIGURE E)	
4	350066-000	BLADE	1
5	290269-000	INNER BLADE COLLAR	1
6	020606-009	* SCREW (5/16-18 X 1-1/2 in.)	4
7	021120-003	* WASHER (M8 x M16 X 1.2 mm T)	4
8	225237-000	FENCE	1
9	870033-002	FENCE SCALE	1
10	900848-000	BASE ASSEMBLY (SEE FIGURE C)	
11	020326-001	ARBOR SCREW	1
12	021600-003	ARBOR WASHER	1
13	020703-013	SCREW	1
14	303511-000	DUST COLLECTOR SLEEVE	1
15	330027-000	RUBBER SLEEVE	1
16	089100100133	* SCREW (10-32 X 5/16 IN)	1
17	028939-006	SHOULDER SCREW	1
18	901018-000	LOWER GUARD ASSEMBLY (SEE FIGURE B)	
19	020715-009	* SCREW W/WASHER (M6 X 1 X 35 mm)	4
20	028921-003	* SCREW (10-32 X 20 mm)	1
21	225239-000	UPPER GUARD	1
22	020504-005	SET SCREW	1
23	290257-000	OUTER BLADE COLLAR	1
24	880048-002	LASER ASSEMBLY	1
25	020325-001	LASER ARBOR SCREW	1
26	373008-000	LASER	1
27	867227-006	LASER CARD (NOT SHOWN)	1
28	867227-000	LOGO PLATE (NOT SHOWN)	1
29	867217-004	UPPER GUARD LABEL (NOT SHOWN)	1
30	910012-000	PLASTIC BAG (NOT SHOWN)	1
31	867227-009	ARM GUARD LABEL (NOT SHOWN)	1

* STANDARD HARDWARE ITEM – MAY BE PURCHASED LOCALLY

WARNING: Improper repair of a double insulated tool can result in damages to the double insulation system possibly causing electrical shock or electrocution. Any repairs requiring disassembly of your tool requires safety testing and should only be performed by a Ryobi Authorized Service Center. For the service center nearest you call 1-800-525-2579 in the United States or 1-866-897-9624 in Canada.

FIGURE B

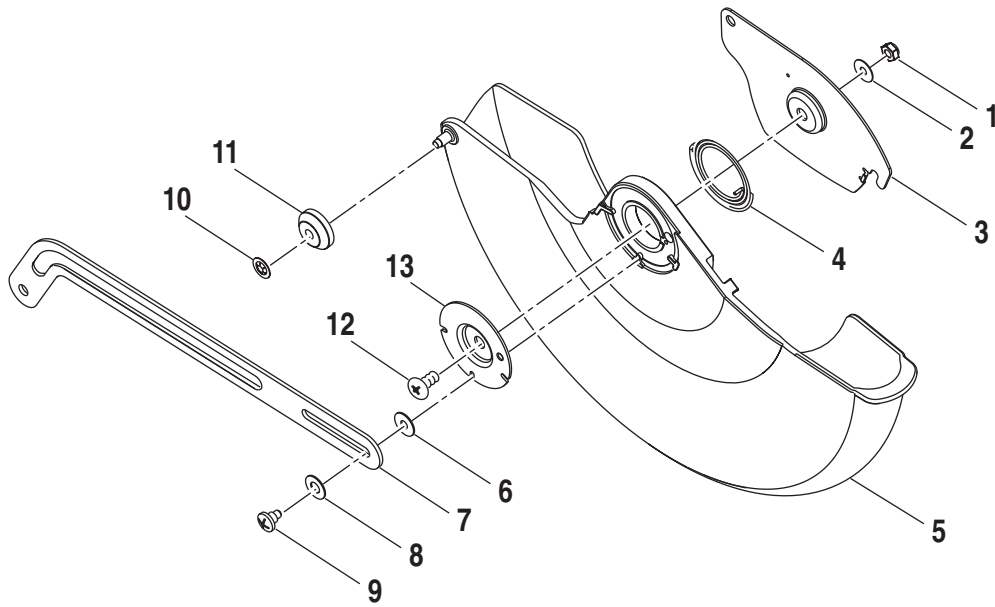

RYOBI 12 in. (305 mm) MITER SAW – MODEL NO. TS1551

The model number will be found on a plate attached to the motor housing. Always mention the model number in all correspondence regarding your **Miter Saw** or when ordering repair parts.

PARTS LIST FOR FIGURE B

KEY NO.	PART NUMBER	DESCRIPTION	QTY.
1	022307-001	* NUT (10-32)	1
2	021108-006	* WASHER (13/64 x 15/32 x 0.5T)	1
3	270578-000	PLATE	1
4	029303-001	GUARD SPRING	1
5	080018001556	LOWER GUARD	1
6	021119-002	* WASHER (5.5 x 16 x 0.8T)	1
7	270579-000	LEVER	1
8	021103-010	* WASHER (7.5 x 16 x 1.5T)	1
9	028931-002	* SCREW (M5 x 0.8P)	1
10	022704-001	RETAINING CLIP	1
11	330060-000	LOWER GUARD BUMPER	1
12	028939-012	SCREW (10-32)	1
13	270376-005	LOWER GUARD PLATE	1
14	867227-001	GUARD WARNING LABEL (NOT SHOWN)	1
	983000-282	OPERATOR'S MANUAL	
	5-06-09		
	(REV:03)		

* STANDARD HARDWARE ITEM – MAY BE PURCHASED LOCALLY

WARNING: Improper repair of a double insulated tool can result in damages to the double insulation system possibly causing electrical shock or electrocution. Any repairs requiring disassembly of your tool requires safety testing and should only be performed by a Ryobi Authorized Service Center. For the service center nearest you call 1-800-525-2579 in the United States or 1-866-897-9624 in Canada.

RYOBI 12 in. (305 mm) MITER SAW – MODEL NO. TS1551

FIGURE C

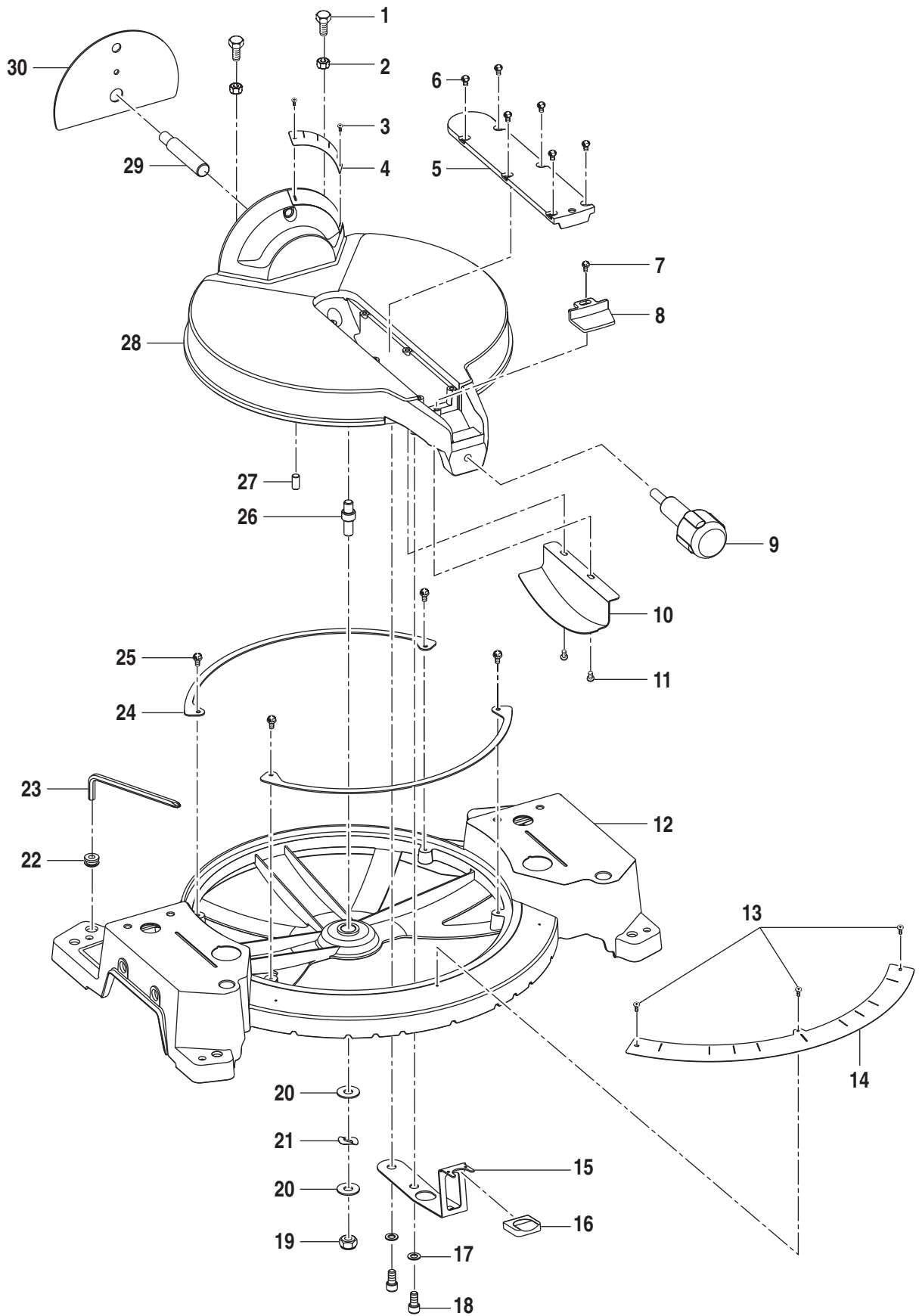

RYOBI 12 in. (305 mm) MITER SAW – MODEL NO. TS1551

The model number will be found on a plate attached to the motor housing. Always mention the model number in all correspondence regarding your **Miter Saw** or when ordering repair parts.

PARTS LIST FOR FIGURE C

KEY NO.	PART NUMBER	DESCRIPTION	QTY.
1	020314-015	BEVEL POSITION HEX SCREW	2
2	022116-001	HEX NUT	2
3	024400-000	COACH SCREW	2
4	870033-001	BEVEL SCALE	1
5	303580-000	TABLE INSERT	1
6	020804-011	SCREW	6
7	020716-007	* SCREW W/WASHER (M4 X 8L)	1
8	303515-000	MITER POINTER.....	1
9	900786-002	MITER HANDLE	1
10	270576-000	TABLE GUARD	1
11	020704-002	SCREW W/WASHER.....	2
12	225234-000	BASE	1
13	024400-000	COACH SCREW	3
14	870033-000	MITER SCALE	1
15	270575-000	SPRING INDEX	1
16	303254-000	MITER INDEX GRIP	1
17	021120-003	* WASHER (8 x 16 x 1.2T)	2
18	020606-011	HEX SOCKET BOLT	2
19	022308-001	NYLON NUT	1
20	021109-011	* WASHER (0.505 in. X 13/16 in. X 1T)	2
21	021403-001	WAVE WASHER	1
22	330030-000	GROMMET	1
23	040027-001	WRENCH (1/4 in. 100L).....	1
24	303514-000	SHOE	2
25	020726-003	SCREW W/WASHER.....	4
26	028961-001	SHOULDER BOLT	1
27	020505-009	SET SCREW	1
28	225235-000	TABLE	1
29	028307-007	BEVEL SHAFT	1
30	270577-000	PIVOT SHOE	1
31	867227-001	NO HANDS LABEL (NOT SHOWN)	2

*** STANDARD HARDWARE ITEM – MAY BE PURCHASED LOCALLY**

WARNING: Improper repair of a double insulated tool can result in damages to the double insulation system possibly causing electrical shock or electrocution. Any repairs requiring disassembly of your tool requires safety testing and should only be performed by a Ryobi Authorized Service Center. For the service center nearest you call 1-800-525-2579 in the United States or 1-866-897-9624 in Canada.

FIGURE D

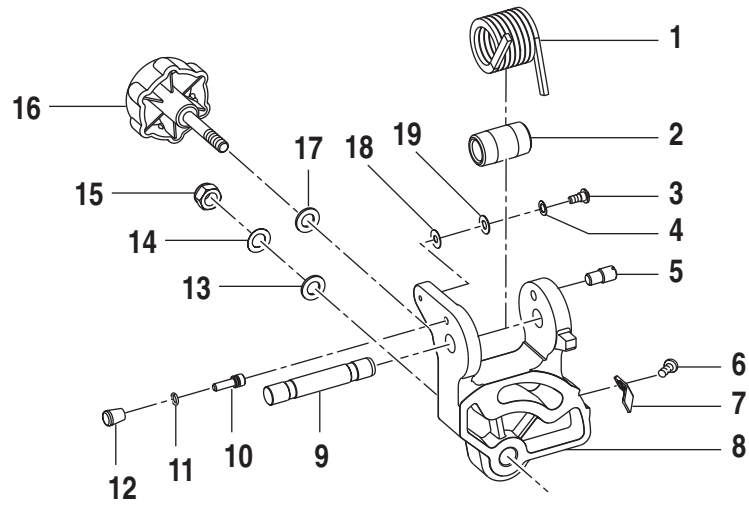

RYOBI 12 in. (305 mm) MITER SAW – MODEL NO. TS1551

The model number will be found on a plate attached to the motor housing. Always mention the model number in all correspondence regarding your **Miter Saw** or when ordering repair parts.

PARTS LIST FOR FIGURE D

KEY NO.	PART NUMBER	DESCRIPTION	QTY.
1	029233-001	TORSION SPRING	1
2	303226-000	TORSION SPRING SPACER	1
3	020113-008	SHOULDER SCREW	1
4	021403-007	WAVY WASHER	1
5	028969-001	VERTICLE STOP PIN	1
6	020716-007	SCREW W/WASHER	1
7	303510-000	BEVEL INDICATOR	1
8	240060-000	PIVOT	1
9	132068-000	PIVOT BOLT	1
10	130064-000	LATCH PIN	1
11	025102-002	"O" RING	1
12	330035-000	RUBBER SLEEVE	1
13	021117-003	WASHER	1
14	021611-000	WAVY WASHER	1
15	022300-001	NUT	1
16	303451-002	BEVEL HANDLE	1
17	021109-021	WASHER	1
18	021101-033	WASHER	1
19	021103-010	WASHER	1

WARNING: Improper repair of a double insulated tool can result in damages to the double insulation system possibly causing electrical shock or electrocution. Any repairs requiring disassembly of your tool requires safety testing and should only be performed by a Ryobi Authorized Service Center. For the service center nearest you call 1-800-525-2579 in the United States or 1-866-897-9624 in Canada.

RYOBI 12 in. (305 mm) MITER SAW – MODEL NO. TS1551

FIGURE E

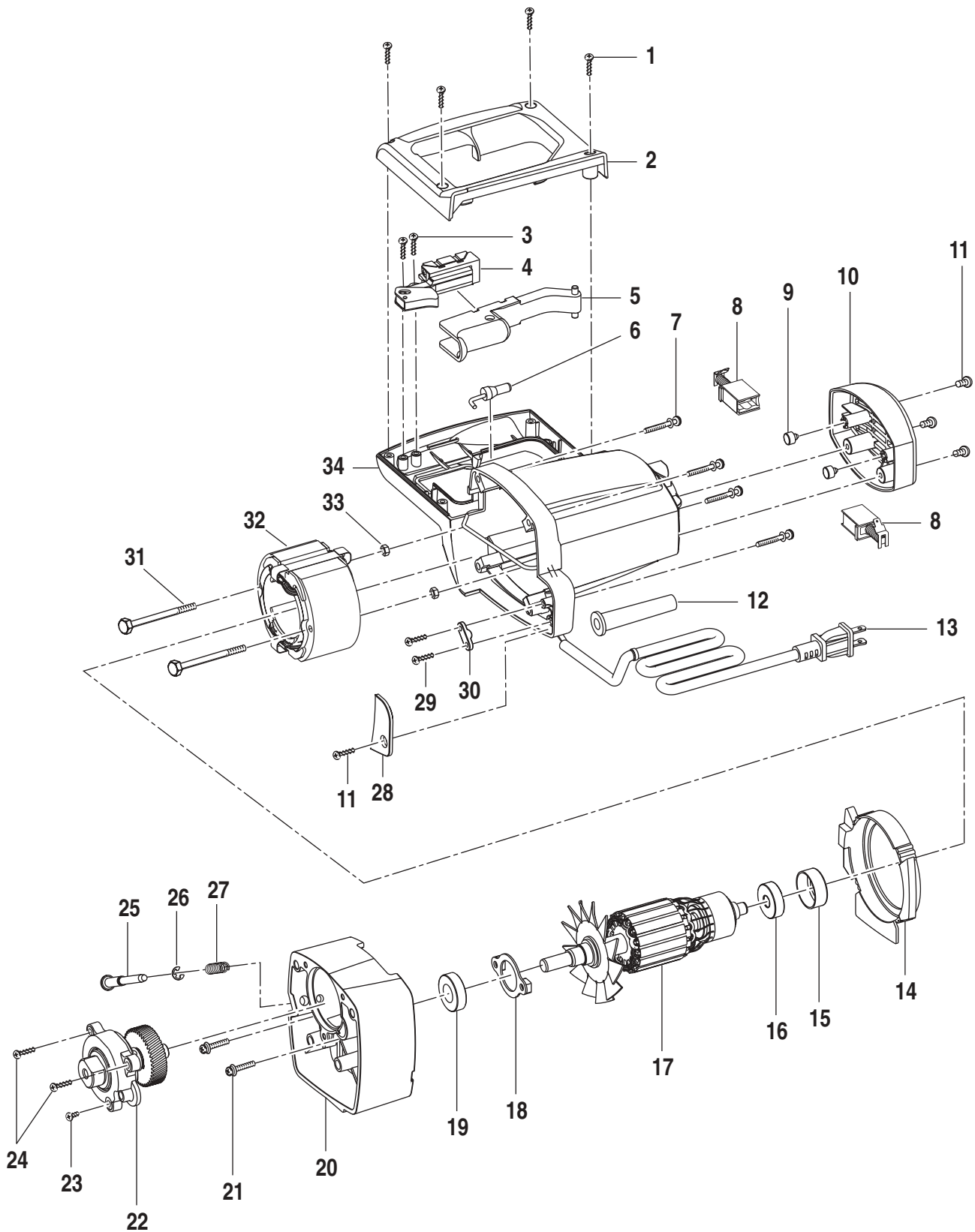

RYOBI 12 in. (305 mm) MITER SAW – MODEL NO. TS1551

The model number will be found on a plate attached to the motor housing. Always mention the model number in all correspondence regarding your **Miter Saw** or when ordering repair parts.

PARTS LIST FOR FIGURE E

KEY NO.	PART NUMBER	DESCRIPTION	QTY.
1	020132-003	SCREW	4
2	303520-000	SWITCH HANDLE (BOTTOM)	1
3	020132-001	SCREW	2
4	090043-000	SWITCH	1
5	303519-000	TRIGGER	1
6	364001-001	TERMINAL	1
7	020703-009	* SCREW W/WASHER (M5 X 25 mm)	4
8	984795-001	BRUSH ASSEMBLY	2
9	303085-000	BRUSH BUMPER RETAINER	2
10	303517-000	MOTOR HOUSING END CAP	1
11	020132-001	SCREW	4
12	330021-000	CORD SLEEVE	1
13	900787-001	CORD W/PLUG	1
14	303435-000	BAFFLE RING	1
15	330036-000	BEARING COVER	1
16	050004-300	BEARING (6201LLU)	1
17	984794-001	ARMATURE ASSEMBLY (INCLUDES KEY NOS. 16, 18, 19)	1
18	270026-000	BEARING PLATE	1
19	050001-100	BEARING (6001LLU)	1
20	984793-001	GEAR HOUSING ASSEMBLY	1
21	020702-005	SCREW W/WASHER	2
22	900853-001	OUTPUT SPINDLE AND GEAR ASSEMBLY	1
23	020704-004	SCREW (SHORT)	1
24	020704-006	SCREW (LONG)	2
25	290206-000	ARBOR LOCK	1
26	023201-001	RETAINING RING	1
27	029151-001	SPRING	1
28	303521-000	CORD CLAMP COVER	1
29	020132-008	* SCREW (M4 X 14 mm)	2
30	303006-000	CORD CLAMP	1
31	028600-001	HEX HEAD BOLT	2
32	170031-001	FIELD W/LEADS	1
33	022101-000	NYLON NUT	2
34	303518-000	MOTOR HOUSING	1
35	871051-003	DATA PLATE (NOT SHOWN)	1
36	867227-004	WARNING LABEL - FRENCH/SPANISH (NOT SHOWN)	1
37	867217-003	MOTOR 3D LOGO PLATE (NOT SHOWN)	1
38	867217-002	WARNING LABEL - ENGLISH (NOT SHOWN)	1

* STANDARD HARDWARE ITEM – MAY BE PURCHASED LOCALLY

WARNING: Improper repair of a double insulated tool can result in damages to the double insulation system possibly causing electrical shock or electrocution. Any repairs requiring disassembly of your tool requires safety testing and should only be performed by a Ryobi Authorized Service Center. For the service center nearest you call 1-800-525-2579 in the United States or 1-866-897-9624 in Canada.