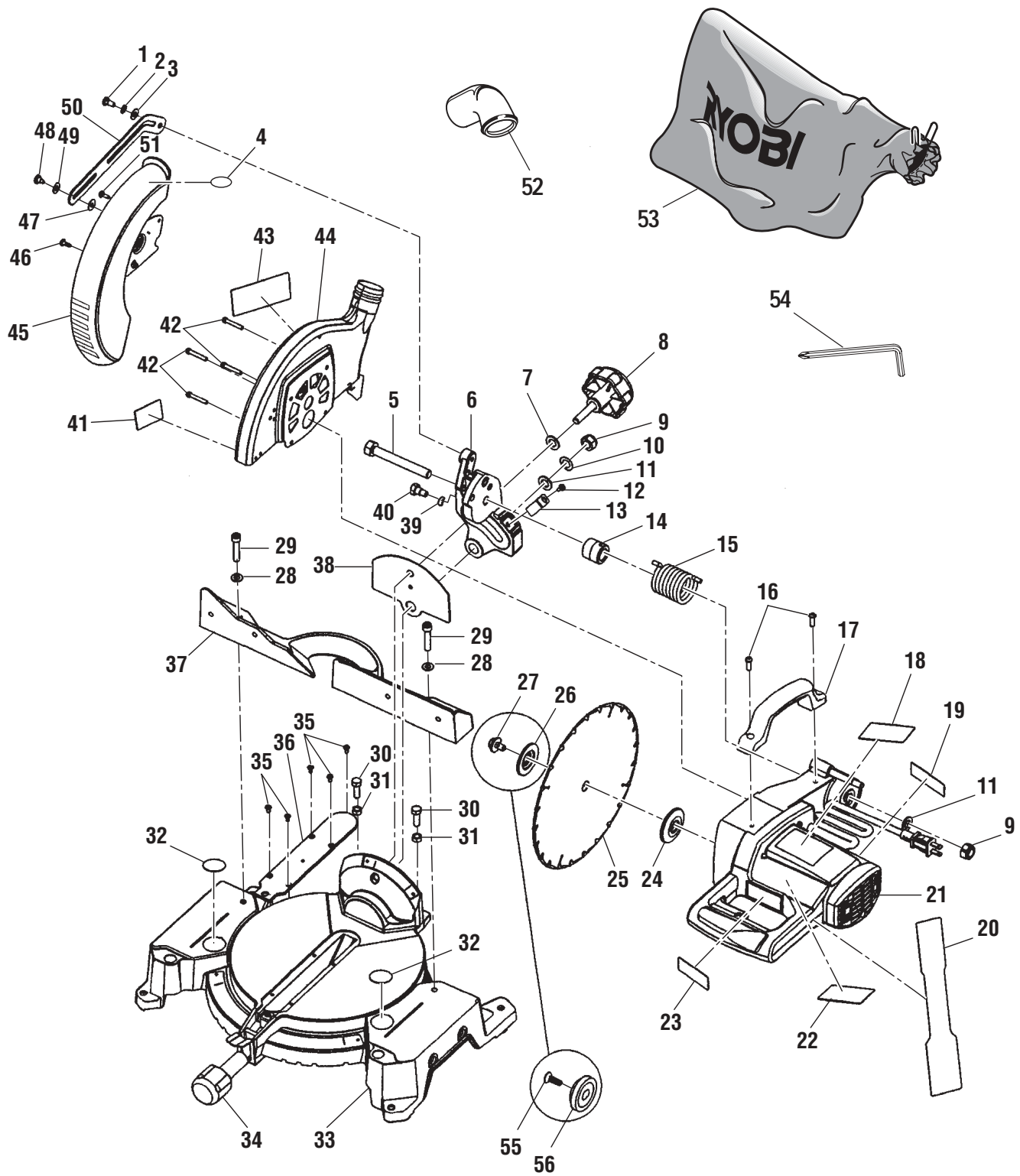

FIGURE A



**WARNING:** Improper repair of a double insulated tool can result in damages to the double insulation system possibly causing electrical shock or electrocution. Any repairs requiring disassembly of your tool requires safety testing and should only be performed by a Ryobi Authorized Service Center. For the service center nearest you call 1-800-525-2579 in the United States or 1-866-897-9624 in Canada.

## RYOBI 10 in. (254 mm) COMPOUND MITER SAW – MODEL NO. TS1352

The model number will be found on a plate attached to the motor housing. Always mention the model number in all correspondence regarding your **Miter Saw** or when ordering repair parts.

### PARTS LIST FOR FIGURE A

Key No.	Part Number	Description	Qty.	Key No.	Part Number	Description	Qty.
1	020113008	* Special Screw (M6 x 10L) .....	1	30	020314003	Hex Bolt .....	2
2	021403007	* Wavy Washer (M7.5 x 16 x 0.8T) .	1	31	022116001	Hex Nut .....	2
3	021103010	Flat Washer .....	1	32	867227001	Base Warning Label .....	2
4	867107013	No Hands Warning Label .....	1	33	900843000	Base/Table Assembly .....	1
5	028960000	Arm Pivot Shaft .....	1	34	900786001	Miter Lock Handle .....	1
6	225229000	Pivot .....	1	35	020804000	Screw .....	5
7	021109019	Washer .....	1	36	303506000	Zero Clearance Throat Plate .....	1
8	303451001	Bevel Knob .....	1	37	225230000	Miter Fence .....	1
9	022300001	Nylon Lock Nut .....	2	38	270571000	Spacer .....	1
10	021611000	Wavy Washer .....	1	39	021205001	Lock Washer .....	1
11	021117003	Washer .....	2	40	020145001	Bevel Pivot Shaft .....	1
12	020716007	Screw/Washer Set .....	1	41	867217004	Upper Guard (Warning) .....	1
13	303505000	Bevel Scale Indicator .....	1	42	020704012	Screw .....	4
14	303577000	Sleeve .....	1	43	867107010	Logo Plate (Upper Guard) .....	1
15	029231001	Torsion Spring .....	1	44	900844000	Upper Blade Guard Assembly ...	1
16	020102005	Screw .....	2	45	900980000	Lower Blade Guard Assembly (See Fig. E) .....	1
17	303507000	Handle .....	1	46	020123004	* Screw (#10-32 Pan Hd.) .....	1
18	867217002	Warning Label (English) .....	1	47	021119002	* Flat Washer (M5.5 x 16 x 0.8T) .....	1
19	867217010	Data Plate .....	1	48	028931002	* Screw (M5 x 0.8T) .....	1
20	867217007	Handle Warning Label .....	1	49	021103010	* Flat Washer (M7.5 x 16 x 0.8T) .....	1
21	T990053001	Motor Assembly (See Fig. F) .....	1	50	270574000	Link Actuator .....	1
22	867117002	Warning Label (French/Spanish) ...	1	51	089100100133	* Screw (#10-32 x 5/16 in. Pan Hd.) ...	1
23	867217003	Logo (Motor) .....	1	52	330019000	Dust Guide .....	1
24	270511000	Inner Blade Flange .....	1	53	900324006	Dust Bag .....	1
25	350056001	Blade .....	1	54	040027000	Hex Key (6 mm) .....	1
26	270373000	Outer Blade Flange .....	1	55	020300013	Blade Bolt (Note: For use when using Laser) ..	1
27	020300011	Blade Bolt .....	1	56	373009000	Laser (Note: It is also a Blade Flange) ...	1
28	021120003	* Flat Washer (M8 x 16 x 1.2T) .....	2				
29	020606009	* Bolt (5/16-18 x 1-1/2 in. Soc. Hd.)..	2				

\* STANDARD HARDWARE ITEM – MAY BE PURCHASED LOCALLY

FIGURE B

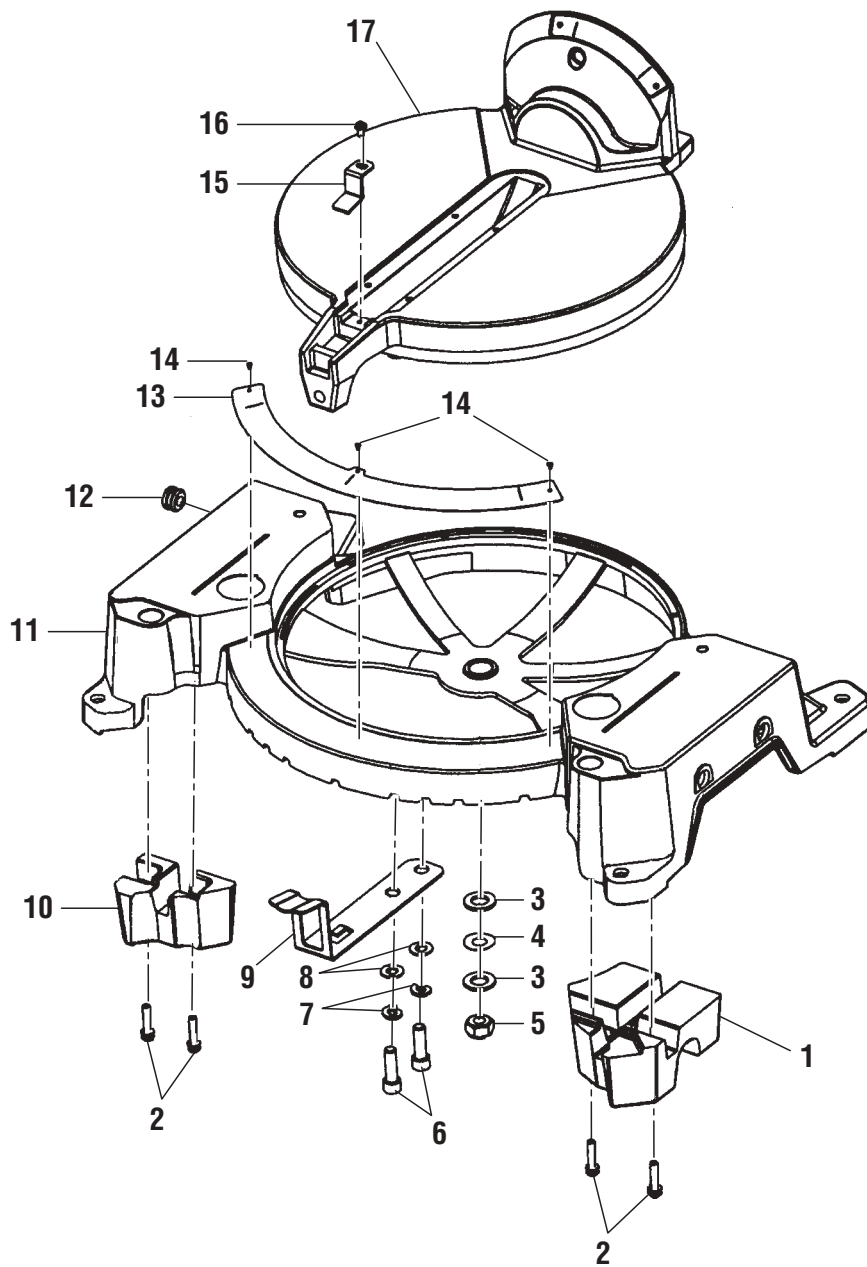

PARTS LIST FOR FIGURE B

Key No.	Part Number	Description	Qty.
1	240062100	Weight "B" .....	1
2	020703011	Set Screw .....	4
3	021109011	Flat Washer .....	2
4	021403001	Wavy Washer .....	1
5	022308001	Nylon Lock Nut .....	1
6	020606013	Socket Head Bolt .....	2
7	021204001	Lock Washer .....	2
8	021120001	Flat Washer .....	2
9	270572000	Miter Lock (Spring Index) .....	1
10	240061100	Weight "A" .....	1
11	225231000	Base .....	1
12	330030000	Rubber Grommet .....	1
13	870028001	Miter Scale .....	1
14	024400000	Rivets .....	3
15	303508000	Miter Scale Indicator .....	1
16	020726003	* Screw (M4 x 0.7 x 8L) .....	1
17	225232000	Table .....	1

\* STANDARD HARDWARE ITEM – MAY BE PURCHASED LOCALLY

FIGURE C

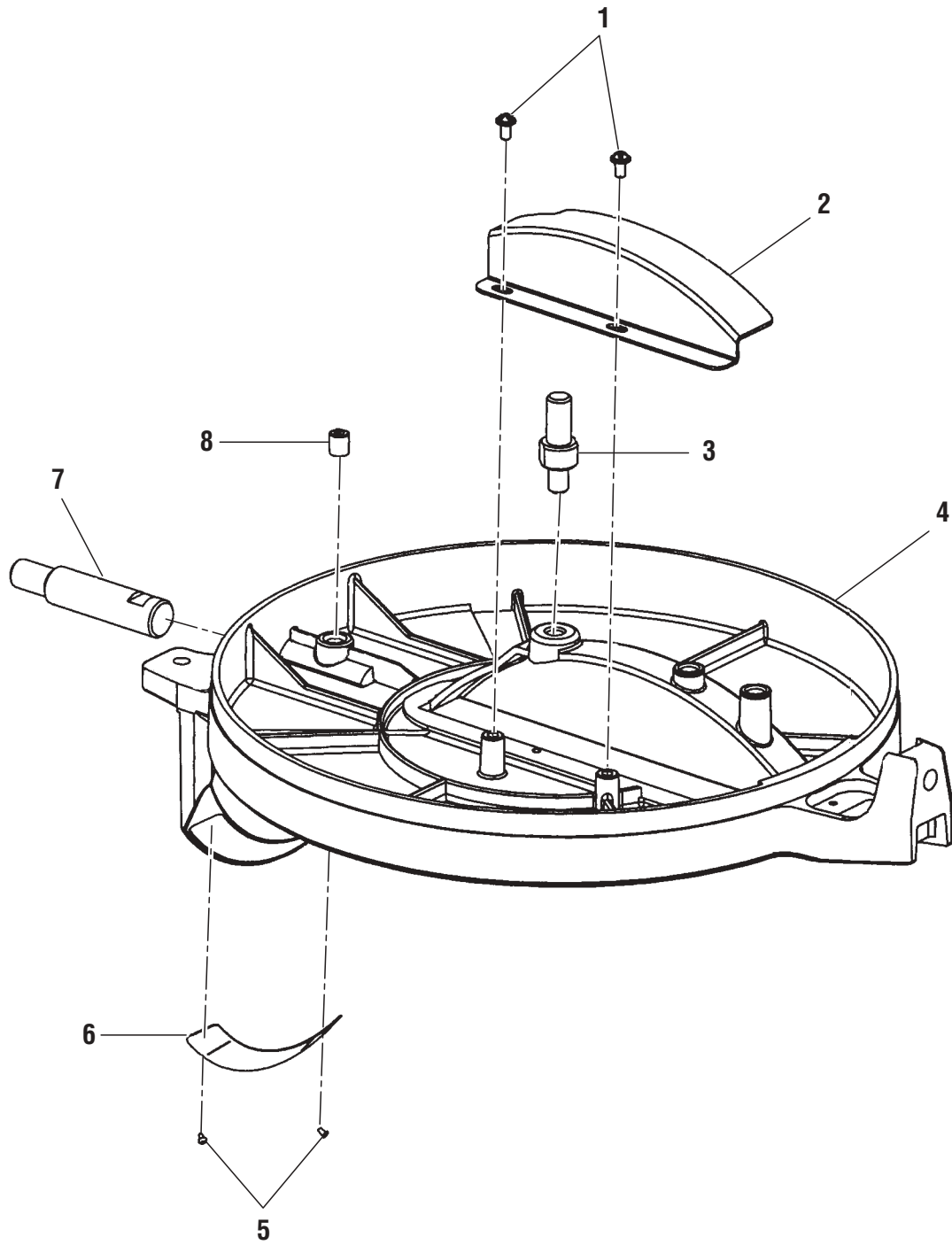

# RYOBI 10 in. (254 mm) COMPOUND MITER SAW – MODEL NO. TS1352

The model number will be found on a plate attached to the motor housing. Always mention the model number in all correspondence regarding your **Miter Saw** or when ordering repair parts.

## PARTS LIST FOR FIGURE C

Key No.	Part Number	Description	Qty.
1	020726003	Screw .....	2
2	270499000	Guard .....	1
3	028961000	Table Spindle .....	1
4	225232000	Miter Table .....	1
5	024400000	Rivets .....	2
6	870029001	Bevel Scale .....	1
7	028968000	Bevel Pivot Shaft .....	1
8	020505007	Lock Screw .....	1

\* STANDARD HARDWARE ITEM – MAY BE PURCHASED LOCALLY

FIGURE D

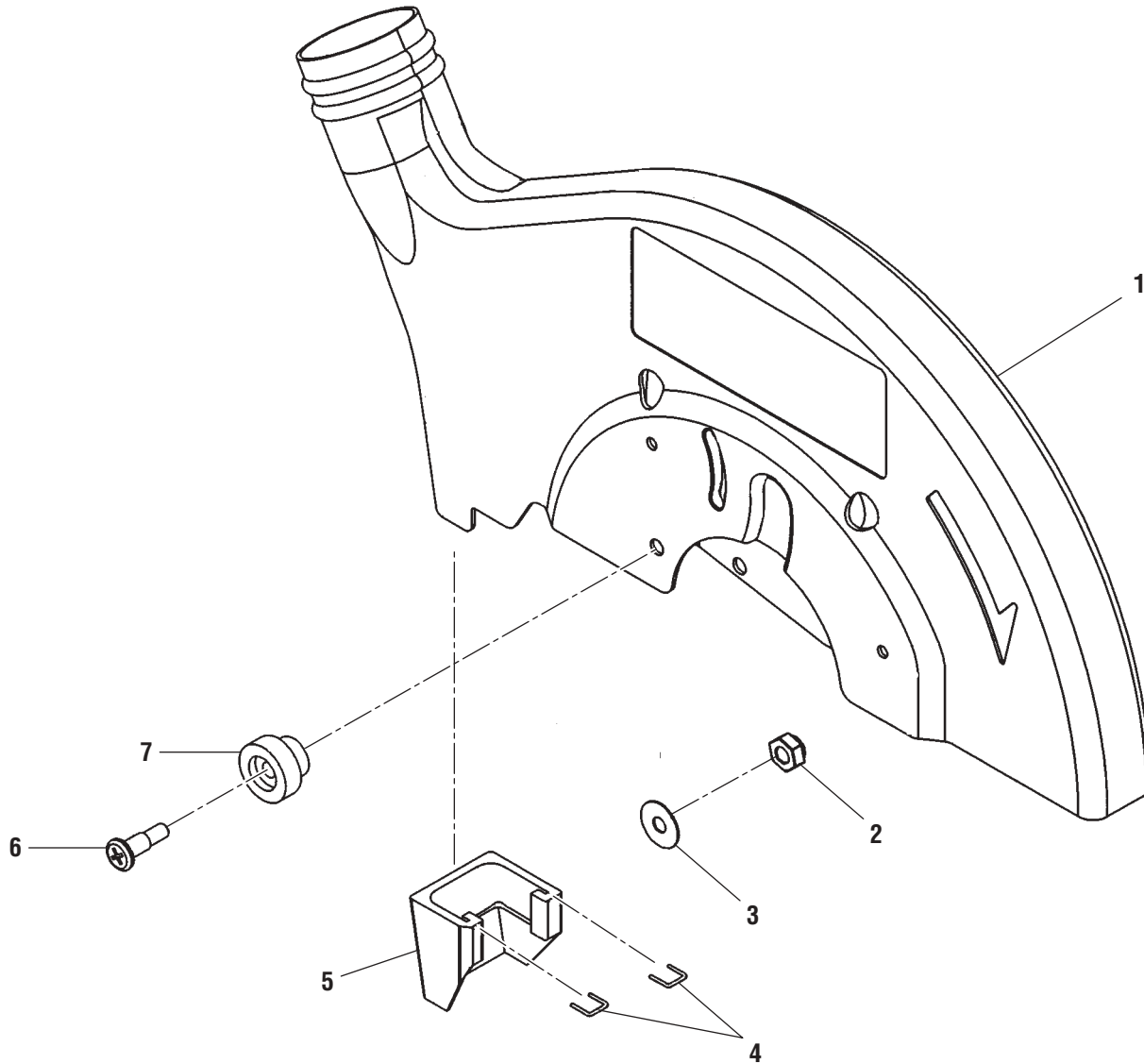

The model number will be found on a plate attached to the motor housing. Always mention the model number in all correspondence regarding your Miter Saw or when ordering repair parts.

**PARTS LIST FOR FIGURE D**

Key No.	Part Number	Description	Qty.
1	290205000	Upper Blade Guard .....	1
2	022307001	Nylon Lock Nut .....	1
3	021108006	Felt Washer .....	1
4	029719001	* Spring .....	2
5	330055000	Dust Shute .....	1
6	028921003	Spring Screw .....	1
7	330027000	Rubber Sleeve .....	1

\* STANDARD HARDWARE ITEM – MAY BE PURCHASED LOCALLY



FIGURE E

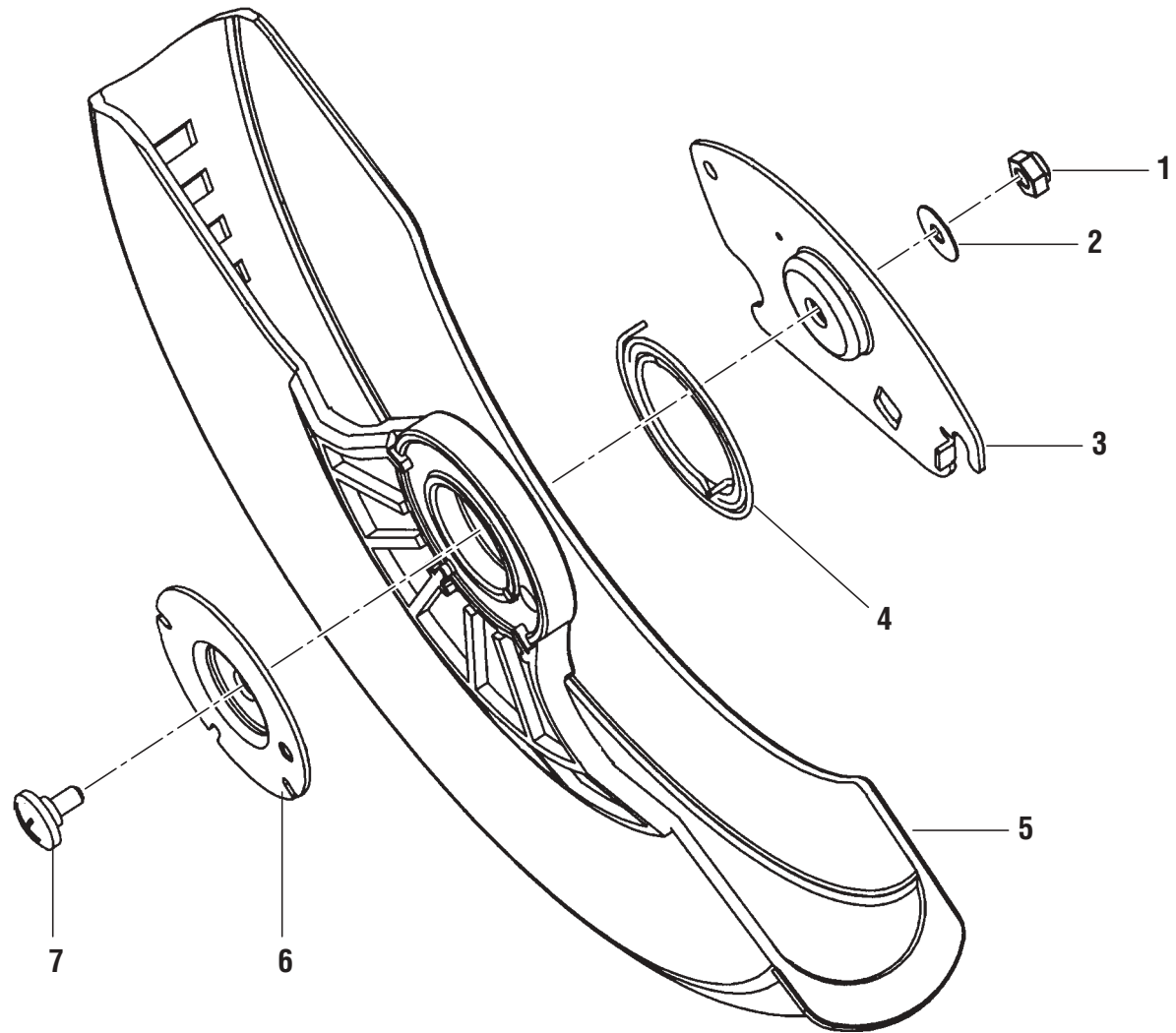

**RYOBI 10 in. (254 mm) COMPOUND MITER SAW – MODEL NO. TS1352**

The model number will be found on a plate attached to the motor housing. Always mention the model number in all correspondence regarding your **Miter Saw** or when ordering repair parts.

**PARTS LIST FOR FIGURE E**

Key No.	Part Number	Description	Qty.
1	022307001	* Nylon Lock Nut (#10-32) .....	1
2	021108006	* Flat Washer (#13/64 x 15/32 x 0.5T) .....	1
3	270573000	Pivot Plate .....	1
4	029303003	Return Spring .....	1
5	303561000	Lower Blade Guard .....	1
6	270376005	Lower Blade Guard Retainer .....	1
7	028939004	Special Screw .....	1
	983000268	Operator's Manual	
	03-15-07		
	(REV:01)		

\* STANDARD HARDWARE ITEM – MAY BE PURCHASED LOCALLY

RYOBI 10 in. (254 mm) COMPOUND MITER SAW - MODEL NO. TS1352

FIGURE F

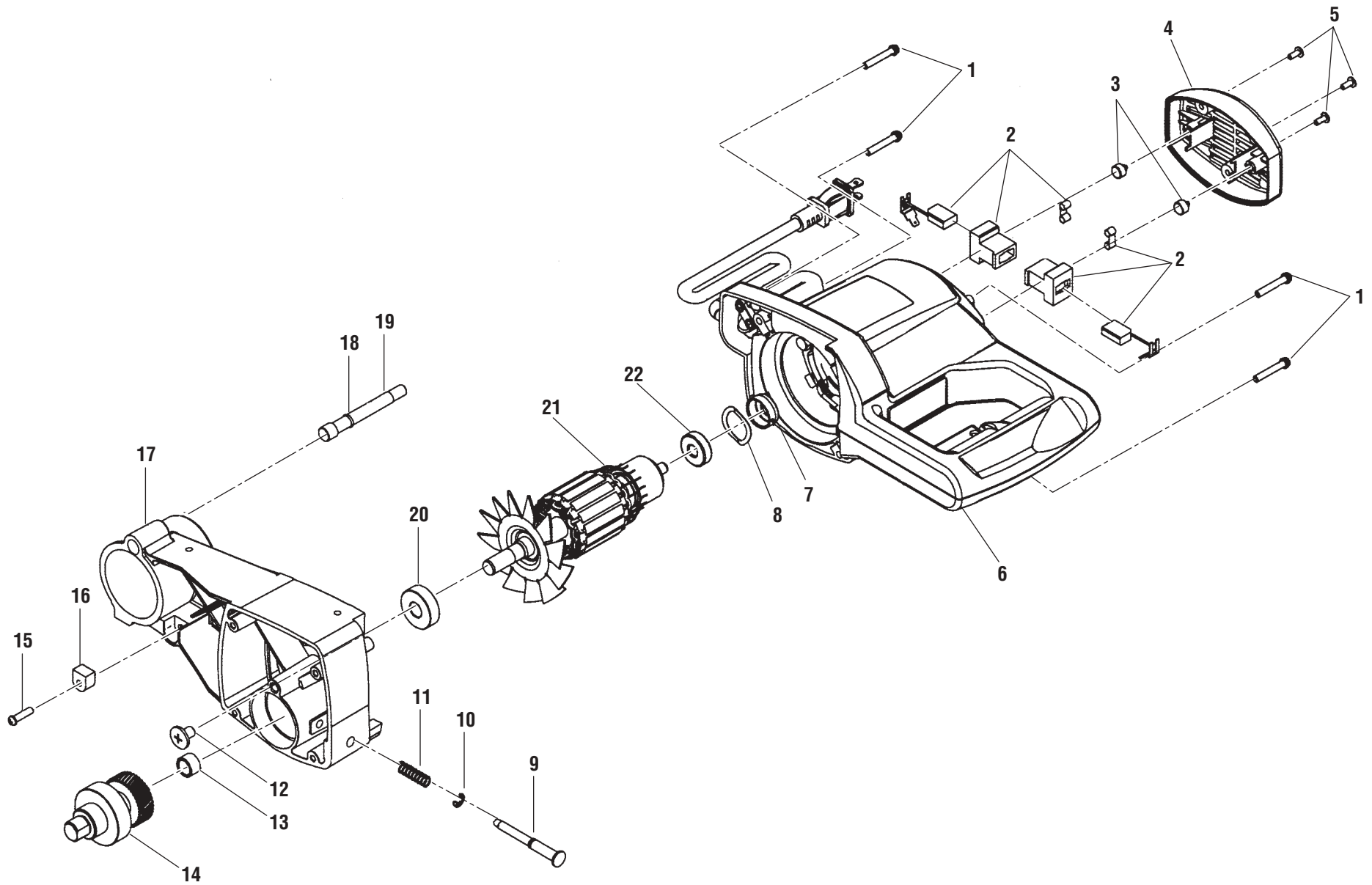

The model number will be found on a plate attached to the motor housing. Always mention the model number in all correspondence regarding your Miter Saw or when ordering repair parts.

**PARTS LIST FOR FIGURE F**

Key No.	Part Number	Description	Qty.
1	020703009	Screw with Washer .....	4
2	984799001	Carbon Brush Assembly .....	2
3	303085000	Brush Holder Cap .....	2
4	303575000	End Cap .....	1
5	020132001	* Screw (M4 x 0.7 x 10L) .....	3
6	900859000	Motor Housing with Field .....	1
7	330052000	Bearing Retainer .....	1
8	021400001	Wavy Washer .....	1
9	290113001	Lock Pin .....	1
10	023206001	Retaining Ring .....	1
11	029151001	Spring .....	1
12	028930003	Screw .....	1
13	052001000	Needle Bearing .....	1
14	984796001	Output Shaft Assembly .....	1
15	020106009	Screw .....	1
16	303024000	Cushion .....	1
17	984797001	Gear Housing Assembly .....	1
18	025100001	O-Ring .....	1
19	026308000	Latch Pin .....	1
20	050010100	Ball Bearing .....	1
21	984798001	Armature Assembly (Includes Key Nos. 20 & 22) .....	1
22	050007000	Ball Bearing .....	1

\* STANDARD HARDWARE ITEM – MAY BE PURCHASED LOCALLY

FIGURE G

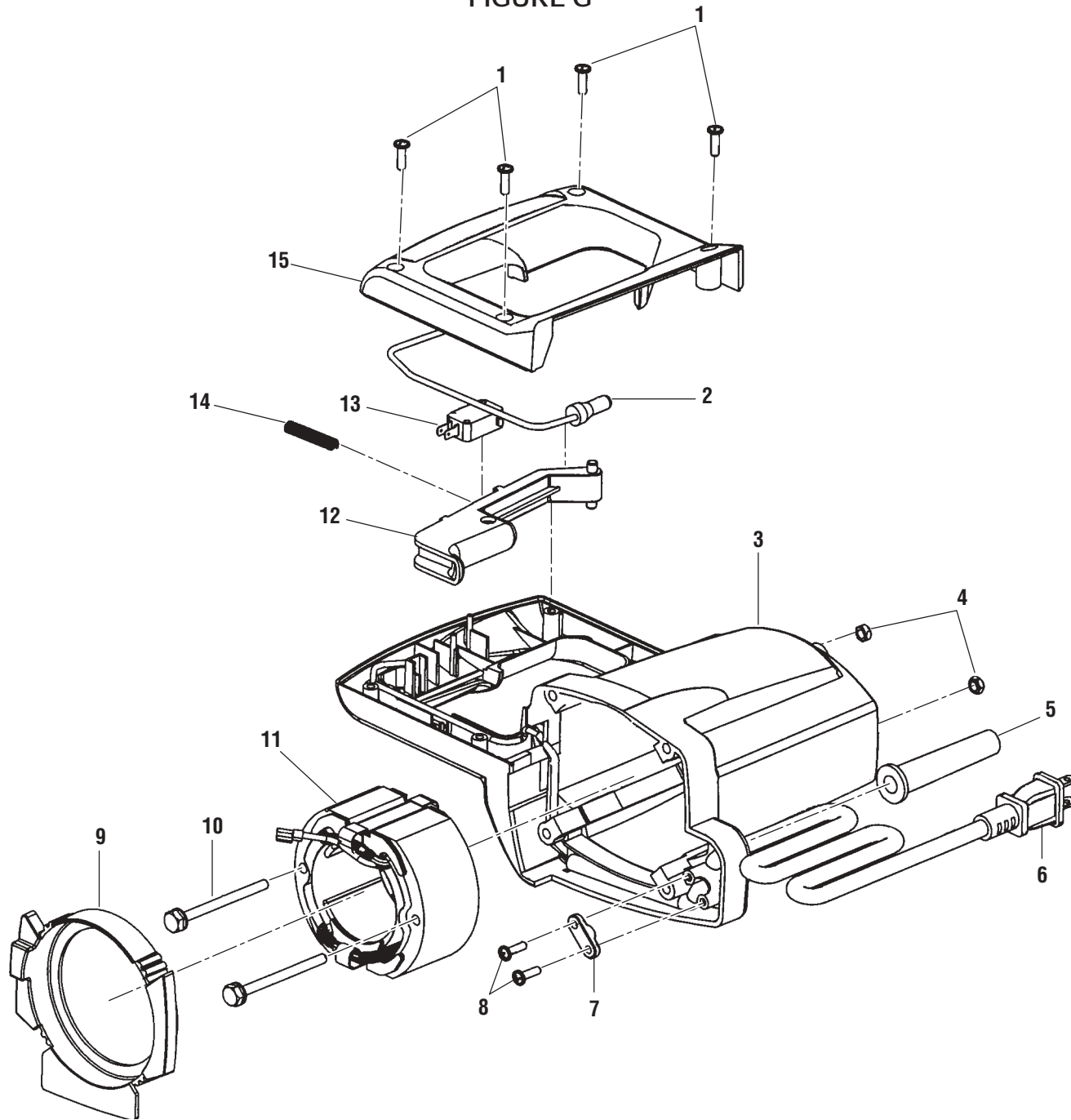

**RYOBI 10 in. (254 mm) COMPOUND MITER SAW – MODEL NO. TS1352**

The model number will be found on a plate attached to the motor housing. Always mention the model number in all correspondence regarding your Miter Saw or when ordering repair parts.

**PARTS LIST FOR FIGURE G**

Key No.	Part Number	Description	Qty.
1	020132003	Screw .....	4
2	364001001	Terminal .....	1
3	303504000	Motor Housing .....	1
4	022101000	Nylon Lock Nut .....	2
5	330021000	Bend Relief .....	1
6	900787000	Power Cord .....	1
7	303006000	Cord Clamp .....	1
8	020132000	* Screw (M4 x 14L) .....	2
9	303435000	Baffle .....	1
10	028600001	Screw with Washer .....	2
11	170024000	Field w/Leads .....	1
12	303436000	Switch Actuator .....	1
13	303288000	Micro Switch .....	1
14	029166001	Spring .....	1
15	303431000	Handle Cover .....	1

\* STANDARD HARDWARE ITEM – MAY BE PURCHASED LOCALLY