

RYOBI MITER SAW - MODEL NUMBER TS1341

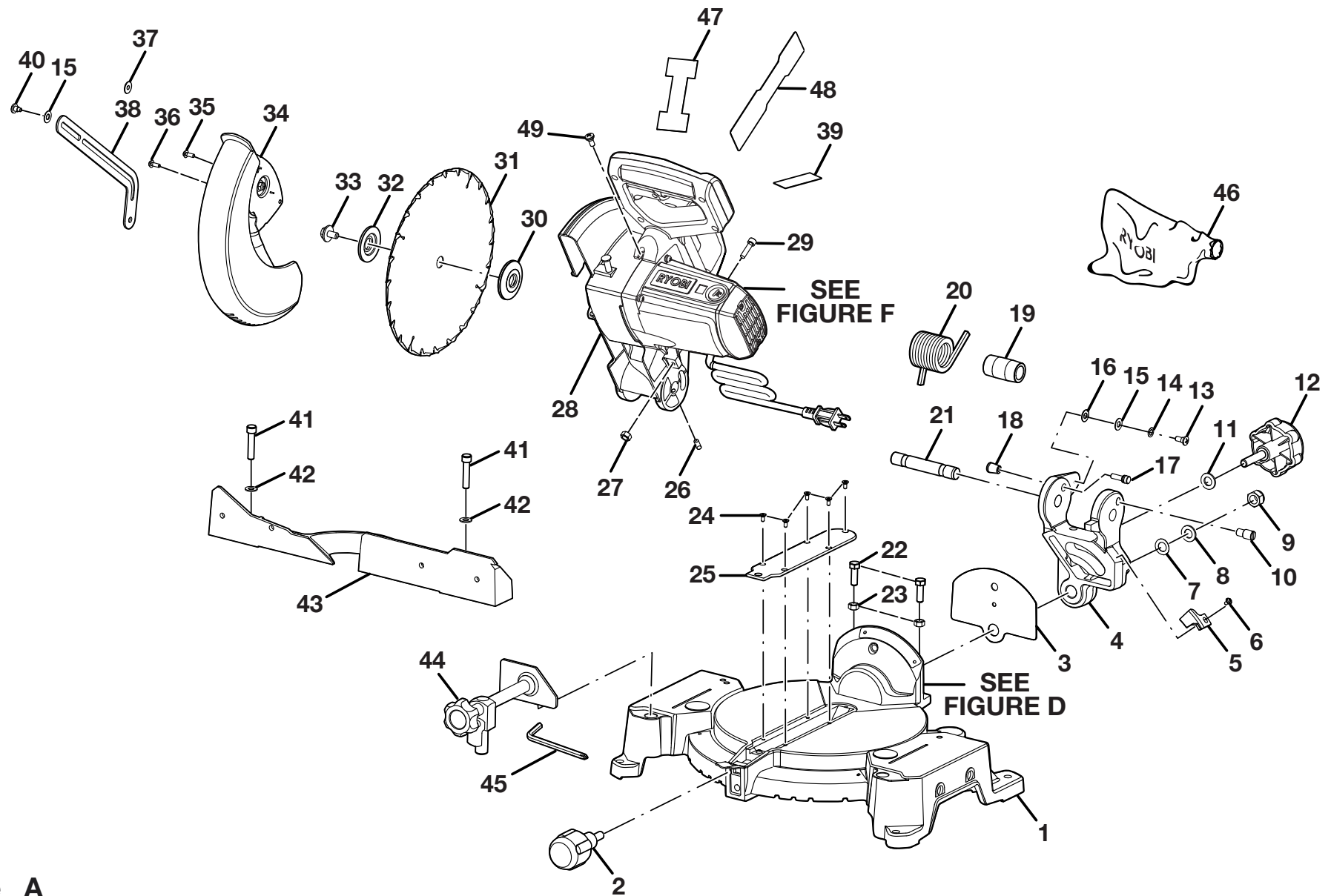

Figure A

RYOBI MITER SAW – MODEL NUMBER TS1341

The model number will be found on a plate attached to the motor housing. Always mention the model number in all correspondence regarding your **MITER SAW** or when ordering repair parts.

PARTS LIST (FIGURE A)

KEY NO.	PART NUMBER	DESCRIPTION	QTY	KEY NO.	PART NUMBER	DESCRIPTION	QTY
1	089100100701	TABLE AND BASE ASSEMBLY (SEE FIGURE B)	1	28	089100100702	MOTOR ASSEMBLY (120V - 15A) (SEE FIGURE E)	1
2	900786001	MITER KNOB.....	1	29	089100100013	* HEX SOC. BOLT (M6 X 1.0 X 24 mm)	1
3	270571000	SPACER.....	1	30	270511000	INNER BLADE FLANGE	1
4	089100100001	PIVOT	1	31	350056001	BLADE (24T).....	1
5	089100100002	BEVEL SCALE INDICATOR	1	32	270373000	BLADE COLLAR.....	1
6	020716007	* SCREW (M5 X 0.8 X 10 mm PAN HD.).....	1	33	020300011	* ARBOR SCREW	1
7	021117003	* WASHER (M12.2 X 22 X 2T).....	1	34	089100100703	LWR. BLADE GUARD ASSEMBLY (SEE FIGURE E).....	1
8	089100100003	* WAVY WASHER	1	35	089100100133	SCREW (10-32 X 5/16 in. PAN HD.).....	1
9	022300001	* NYLON LOCK NUT (M12 X 1.75P).....	1	36	089100100045	SHOULDER BOLT (10-32 X 5/16 in.).....	1
10	028969001	VERTICAL STOP PIN	1	37	021119002	WASHER (5.5 X 16 X 0.8T)	1
11	021109019	FLAT WASHER	1	38	089100100014	LINK ACTUATOR.....	1
12	089100100004	BEVEL KNOB (M10 X 57 mm).....	1	39	089100100902	DATA LABEL	1
13	089100100005	* SCREW (M6 X 8 mm)	1	40	028931002	* SCREW-SHOULDER (M5 X 8 mm)	1
14	021403007	* WAVY WASHER (7.5 X 12.7 X 0.4T)	1	41	089100100046	HEX SOCKET BOLT (5/16-18 X 1 in.).....	2
15	021103010	* WASHER (7.5 X 16 X 0.8T)	2	42	021120007	WASHER (8 X 14 X 1.2T)	2
16	089100100006	* WASHER (7.5 X 16 X 1.5T)	1	43	089100100049	FENCE.....	1
17	089100100044	LATCH PIN	1	44	900239004	WORK CLAMP	1
18	089100100007	LATCH PIN KNOB	1	45	040027000	WRENCH (1/4 X 100 mm)	1
19	089100100008	SLEEVE	1	46	089100100801	DUST BAG (O.D. 2-1/2 in.).....	1
20	089100100009	TORSION SPRING (6 X 53 mm)	1	47	089100100901	WARNING (HANG TAG).....	1
21	089100100010	ARM PIVOT SHAFT	1	48	089100100050	HANDLE WARNING LABEL	1
22	020314003	HEX SCREW (M8 X 1.25 X 25 mm)	2	49	089100100061	SCREW (M4 X 10 mm PAN HD.) & WASHER (4.3 X 7.5 X 0.8T)	1
23	022116001	HEX NUT (M8 X 1.25).....	2		983000606	OPERATOR'S MANUAL	
24	020804000	* SCREW (M4 X 0.7 X 10 mm)	5		03-15-07	(REV:04)	
25	089100100048	TABLE INSERT	1				
26	089100100011	* SCREW (M6 X 1P X 10 mm - SET).....	1				
27	089100100012	* NUT (M6 X 1P X 4.8T)	1				

WARNING: Improper repair of a double insulated tool can result in damage to the double insulation system possibly causing electrical shock or electrocution. Any repairs requiring disassembly of your tool requires safety testing and should only be performed by a Ryobi Authorized Service Center. For the service center nearest you call 1-800-525-2579.

* STANDARD HARDWARE ITEM – MAY BE PURCHASED LOCALLY

RYOBI MITER SAW - MODEL NUMBER TS1341

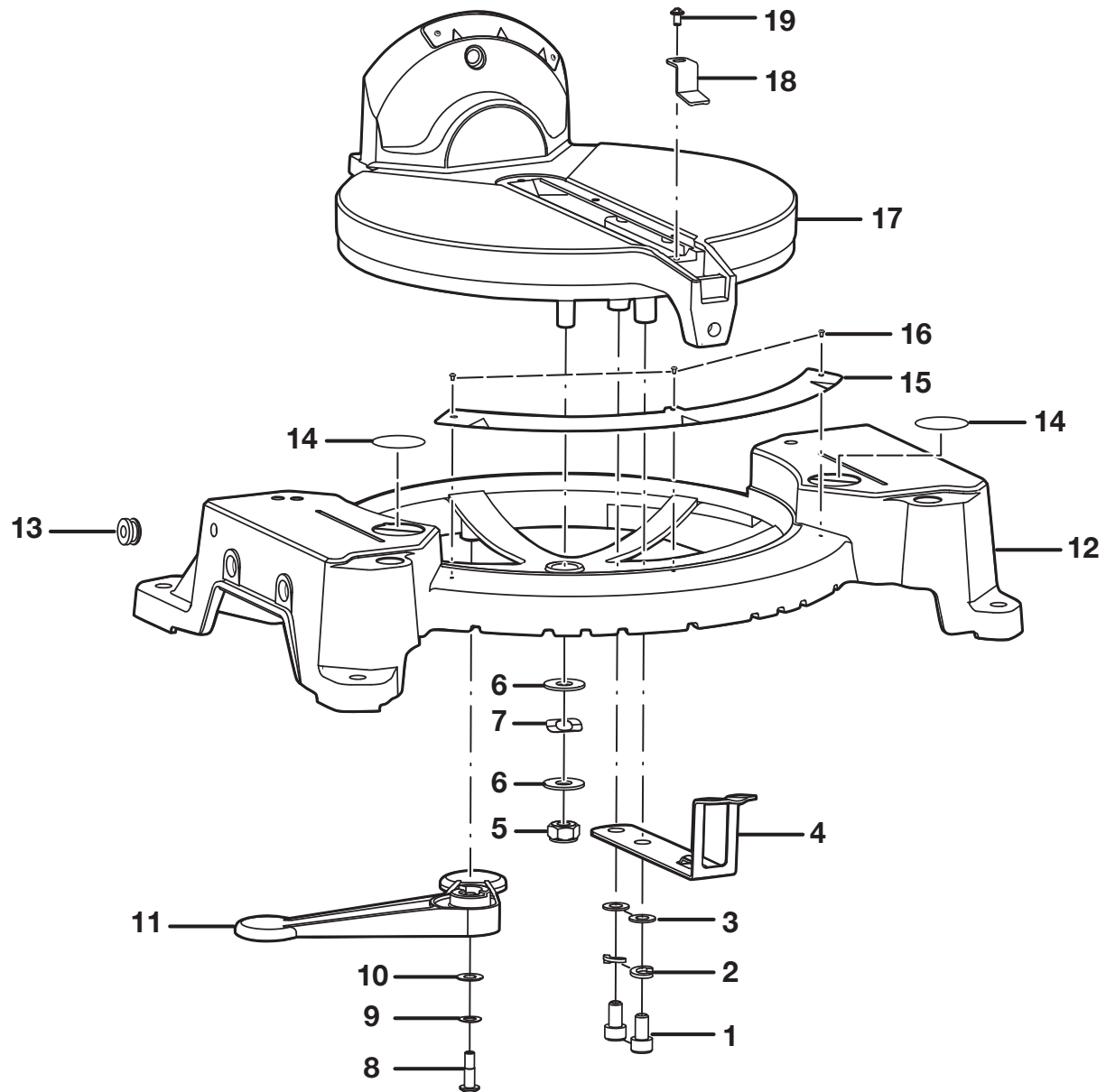

Figure B

RYOBI MITER SAW – MODEL NUMBER TS1341

The model number will be found on a plate attached to the motor housing. Always mention the model number in all correspondence regarding your **MITER SAW** or when ordering repair parts.

PARTS LIST (FIGURE B)

KEY NO.	PART NUMBER	DESCRIPTION	QTY
1	020606013	HEX SOCKET BOLT (5/16 -18 X 14.8 mm).....	2
2	021204001	LOCK WASHER (5/16 in.)	2
3	021120001	* FLAT WASHER (8 X 14 X 2T)	2
4	270572000	SPRING INDEX	1
5	022308001	NYLON NUT (M10 X 1.5P).....	1
6	021109011	FLAT WASHER (10 X 21 X 1.2T)	2
7	021403001	WAVY WASHER (10 X 22 X 0.5T).....	1
8	089100100015	* SCREW (M6 X 1P X 22 mm - PAN HD.).....	1
9	089100100016	* WAVY WASHER (7.5 X 14 X 0.4T).....	1
10	089100100017	* WASHER (7.5 X 14 X 0.4T)	1
11	089100100018	FLIP FOOT	1
12	089100100105	BASE.....	1
13	330030000	GROMMET	1
14	089100100909	WARNING LABEL (NO HANDS)	2
15	870028001	MITER SCALE.....	1
16	024400000	* COACH SCREW	3
17	900846000	TABLE ASSEMBLY	1
18	303508000	MITER INDICATOR	1
19	020726003	* SCREW W/WASHER (M4 X 0.7 X 8 mm).....	1

WARNING: Improper repair of a double insulated tool can result in damage to the double insulation system possibly causing electrical shock or electrocution. Any repairs requiring disassembly of your tool requires safety testing and should only be performed by a Ryobi Authorized Service Center. For the service center nearest you call 1-800-525-2579.

* STANDARD HARDWARE ITEM – MAY BE PURCHASED LOCALLY

RYOBI MITER SAW – MODEL NUMBER TS1341

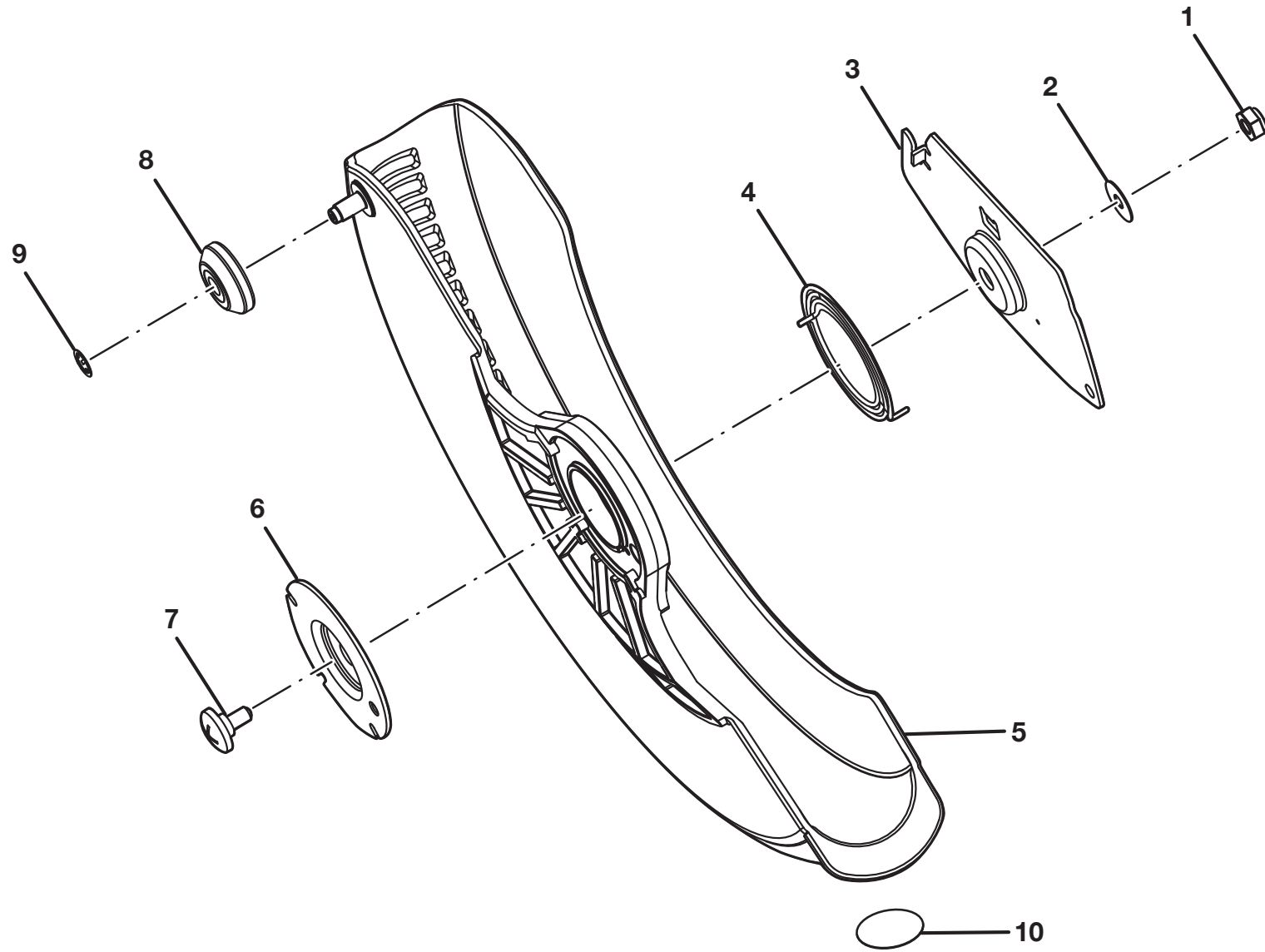

Figure C

RYOBI MITER SAW – MODEL NUMBER TS1341

The model number will be found on a plate attached to the motor housing. Always mention the model number in all correspondence regarding your **MITER SAW** or when ordering repair parts.

PARTS LIST (FIGURE C)

KEY NO.	PART NUMBER	DESCRIPTION	QTY
1	022307001	* NUT (10-32).....	1
2	021108006	* WASHER (13/64 X 15/32 X 0.5T)	1
3	089100100038	PIVOT PLATE	1
4	089100100039	RETURN SPRING.....	1
5	089100100040	LOWER BLADE GUARD	1
6	270376005	LOWER GUARD PLATE	1
7	028939004	SCREW (10-32 SPECIAL)	1
8	303993000	RUBBER WHEEL	1
9	022711000	PLATE NUT	1
10	089100100908	GUARD WARNING LABEL.....	1

WARNING: Improper repair of a double insulated tool can result in damage to the double insulation system possibly causing electrical shock or electrocution. Any repairs requiring disassembly of your tool requires safety testing and should only be performed by a Ryobi Authorized Service Center. For the service center nearest you call 1-800-525-2579.

* STANDARD HARDWARE ITEM – MAY BE PURCHASED LOCALLY

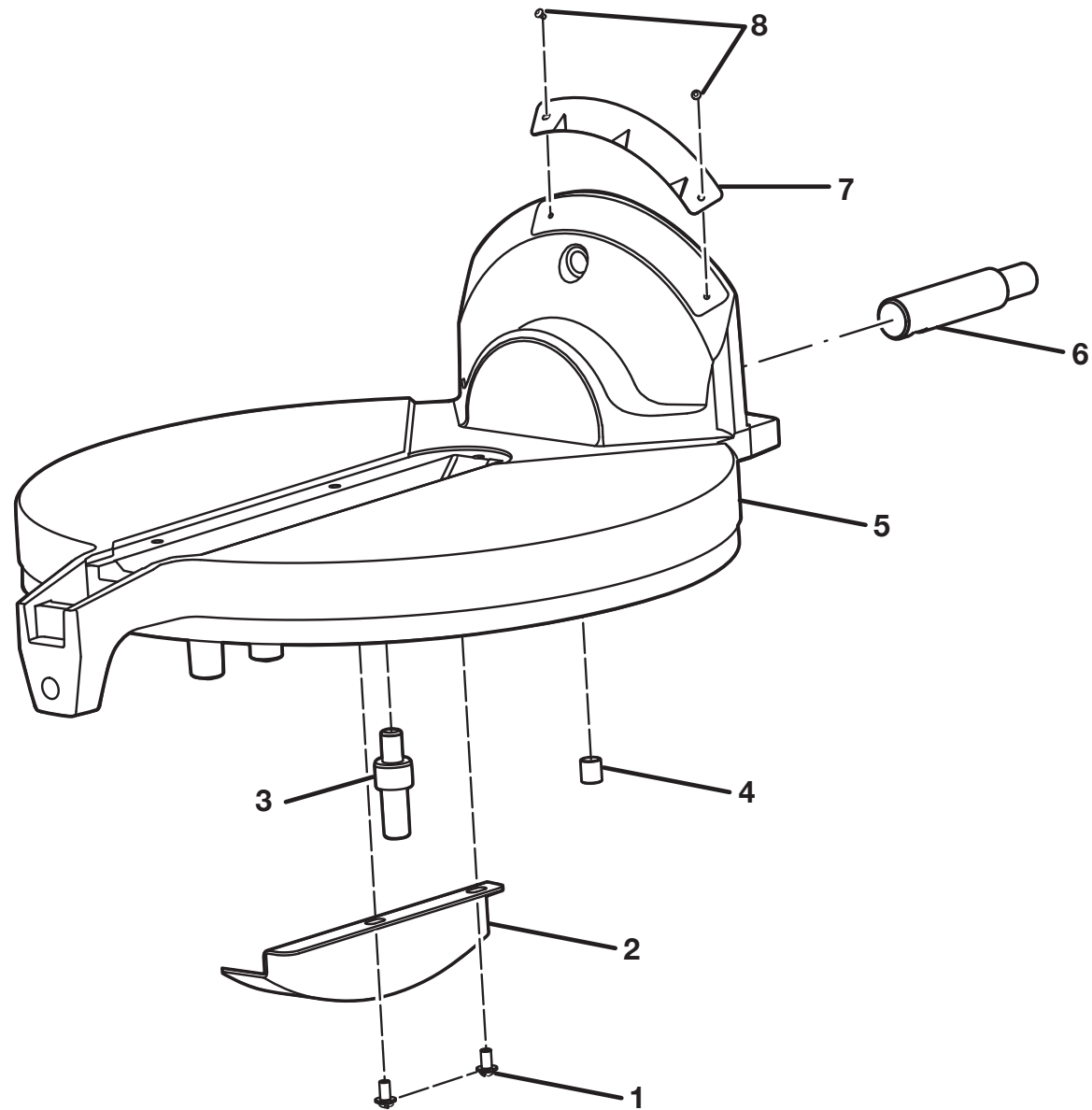

Figure D

RYOBI MITER SAW – MODEL NUMBER TS1341

The model number will be found on a plate attached to the motor housing. Always mention the model number in all correspondence regarding your **MITER SAW** or when ordering repair parts.

PARTS LIST (FIGURE D)

KEY NO.	PART NUMBER	DESCRIPTION	QTY
1	020726003	* SCREW W/WASHER (M4 X 0.7 X 8 mm)	2
2	270499000	SAFETY GUARD	1
3	028961000	PIVOT TABLE	1
4	020505007	* LOCK SCREW (M8 X 1.25 X 9 mm)	1
5	225232000	TABLE.....	1
6	290340000	BEVEL PIVOT SHAFT.....	1
7	870029001	BEVEL SCALE.....	1
8	024400000	* COACH SCREW (RIVET).....	2

WARNING: Improper repair of a double insulated tool can result in damage to the double insulation system possibly causing electrical shock or electrocution. Any repairs requiring disassembly of your tool requires safety testing and should only be performed by a Ryobi Authorized Service Center. For the service center nearest you call 1-800-525-2579.

* STANDARD HARDWARE ITEM – MAY BE PURCHASED LOCALLY

RYOBI MITER SAW – MODEL NUMBER TS1341

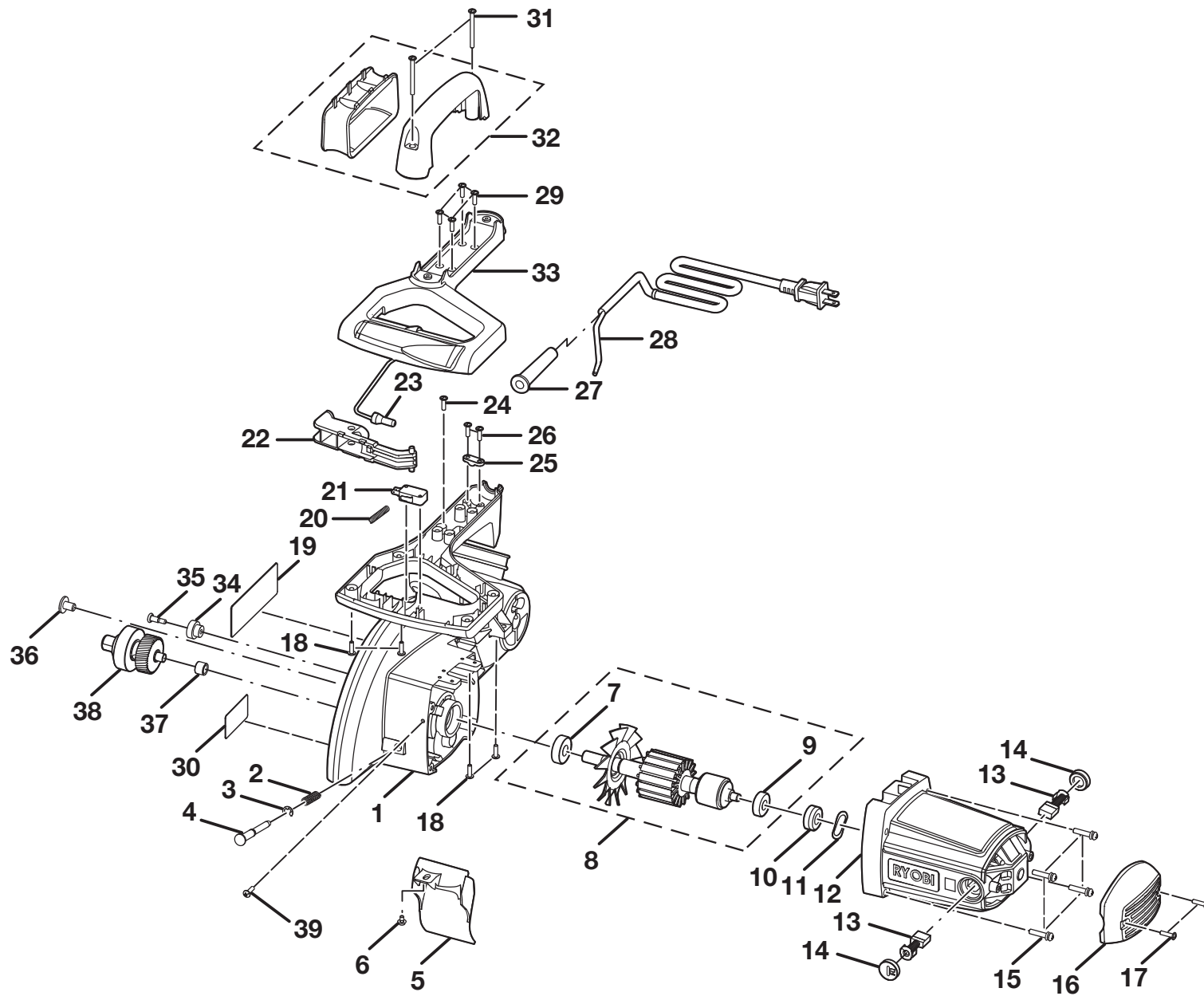

Figure E

RYOBI MITER SAW – MODEL NUMBER TS1341

The model number will be found on a plate attached to the motor housing. Always mention the model number in all correspondence regarding your **MITER SAW** or when ordering repair parts.

PARTS LIST (FIGUR E)

KEY NO.	PART NUMBER	DESCRIPTION	QTY	KEY NO.	PART NUMBER	DESCRIPTION	QTY
1	089100100019	UPPER BLADE GUARD	1	20	029166001	SPRING (6.2 X 0.8 X 37L).....	1
2	029151001	SPRING (7.7 X 1 X 30L).....	1	21	303288000	* MICRO SWITCH (125 - 250 VAC).....	1
3	023206001	RETAINING RING (E-6).....	1	22	089100100027	SWITCH ACTUATOR.....	1
4	290113001	LOCK PIN.....	1	23	089100100051	WIRE NUT	1
5	089100100020	DUST CHUTE.....	1	24	089100100028	* SCREW (M4 X 10 mm - PAN HD.).....	1
6	089100100021	* SCREW & WASHER (M5 X 0.8 X 10 mm).....	1	25	303006000	CORD CLAMP.....	1
7	050010100	BEARING (6201 LLU)	1	26	089100100029	* SCREW (M4 X 14 mm - PAN HD.).....	2
8	089100100710	ARMATURE ASSEMBLY W/ BEARINGS (INCLUDE KEY NOS. 7 AND 9)	1	27	330021000	BEND RELIEF	1
9	050007000	BALL BEARING (608ZZ).....	1	28	089100100052	POWER CORD (AWG 14/2 C)	1
10	330052000	BEARING RETAINER.....	1	29	089100100030	* SCREW & WASHER (M4 X 0.7 X 28 mm).....	4
11	021400001	* WAVY WASHER (20 X 14.5 X 0.3T)	1	30	867217004	WARNING LABEL - UPPER GUARD.....	1
12	089100100704	MOTOR HSG. W/ FIELD	1	31	020132005	* SCREW (M4 X 45 mm - PAN HD.).....	2
13	089100100022	BRUSH (7 X 15 X 17).....	2	32	089100100708	HANDLE ASSEMBLY (CARRY).....	1
14	089100100023	BRUSH COVER.....	2	33	089100100709	HANDLE ASSEMBLY (MAIN).....	1
15	089100100047	* SCREW W/WASHER (M5 X 35 mm).....	4	34	330027000	RUBBER SLEEVE.....	1
16	089100100024	END CAP	1	35	028921003	* SCREW (10 X 32NF X 20 mm).....	1
17	089100100025	* SCREW (M4 X 16 mm - SPECIAL)	2	36	028930003	SCREW (M8 X 1.25P - SPECIAL).....	1
18	020132003	* SCREW (M4 X 14 mm - SPECIAL)	4	37	052001000	NEEDLE BEARING (HK0910)	1
19	089100100905	LOGO PLATE (UPPER GUARD)	1	38	089100100705	OUTPUT SHAFT ASSEMBLY.	1
				39	089100100032	* SCREW (M4 X 0.7P X 10 mm) W/ THICK WASHER	1

WARNING: Improper repair of a double insulated tool can result in damage to the double insulation system possibly causing electrical shock or electrocution. Any repairs requiring disassembly of your tool requires safety testing and should only be performed by a Ryobi Authorized Service Center. For the service center nearest you call 1-800-525-2579.

* STANDARD HARDWARE ITEM – MAY BE PURCHASED LOCALLY

RYOBI MITER SAW – MODEL NUMBER TS1341

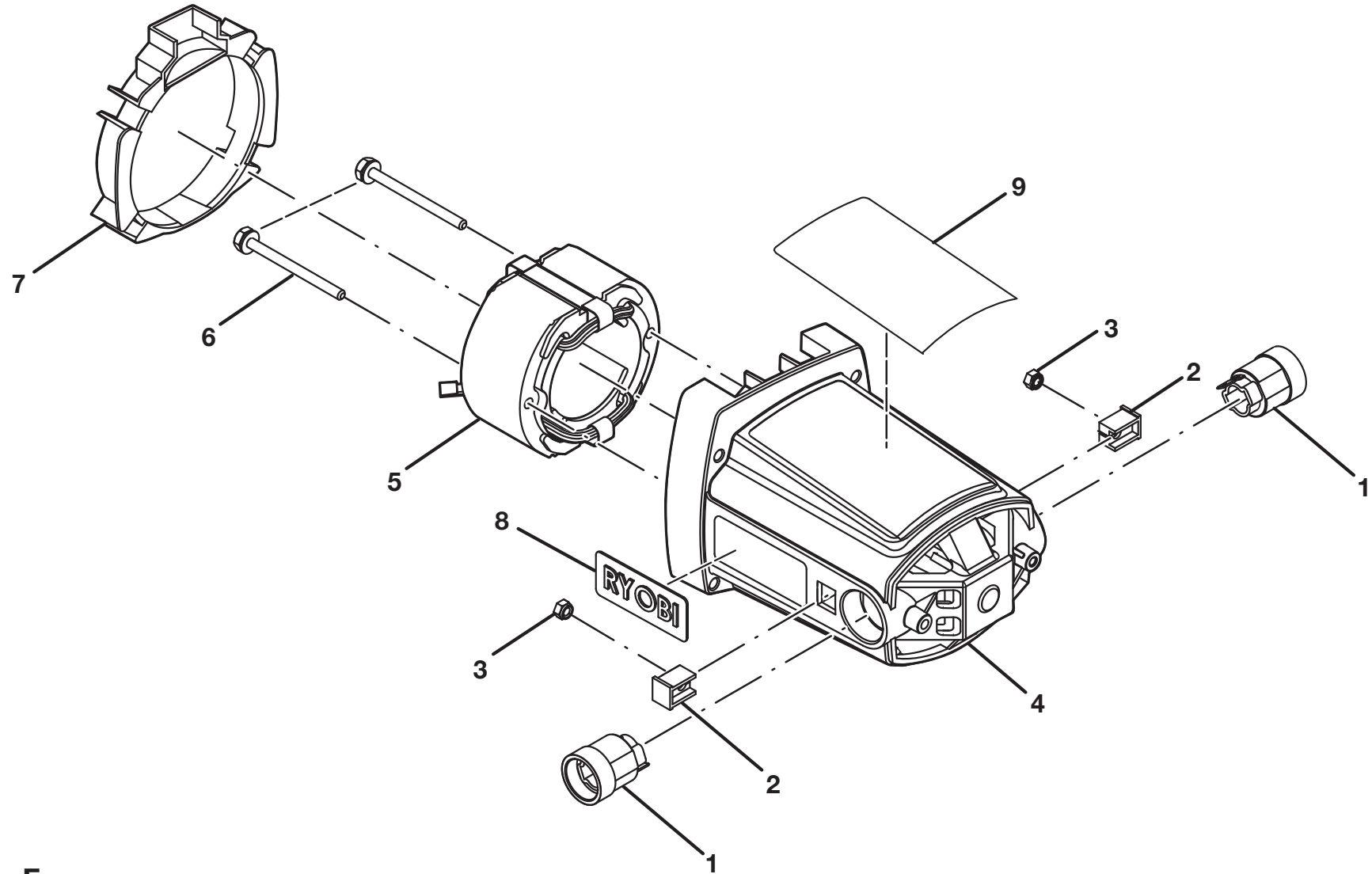

Figure F

RYOBI MITER SAW – MODEL NUMBER TS1341

The model number will be found on a plate attached to the motor housing. Always mention the model number in all correspondence regarding your **MITER SAW** or when ordering repair parts.

PARTS LIST (FIGURE F)

KEY NO.	PART NUMBER	DESCRIPTION	QTY
1	089100100033	BRUSH HOLDER (7 X 15 mm).....	2
2	089100100034	NUT HOLDER (M5)	2
3	089100100035	NYLON NUT (M5)	2
4	089100100036	MOTOR HOUSING	1
5	170060000	FIELD W/LEADS (120V, 40T).....	1
6	028600001	* SCREW W/WASHER (M5 X 0.8 X 60 mm).....	2
7	089100100037	BAFFLE.....	1
8	089100100906	LOGO (60 X 24 mm).....	1
9	089100100907	WARNING LABEL	1

WARNING: Improper repair of a double insulated tool can result in damage to the double insulation system possibly causing electrical shock or electrocution. Any repairs requiring disassembly of your tool requires safety testing and should only be performed by a Ryobi Authorized Service Center. For the service center nearest you call 1-800-525-2579.

* STANDARD HARDWARE ITEM – MAY BE PURCHASED LOCALLY