

**RYOBI**  
**4 in. WET/DRY TILE SAW**  
**MODEL NUMBER TC401**  
**REPAIR SHEET**

RYOBI 4 in. WET/DRY TILE SAW – MODEL NUMBER TC401

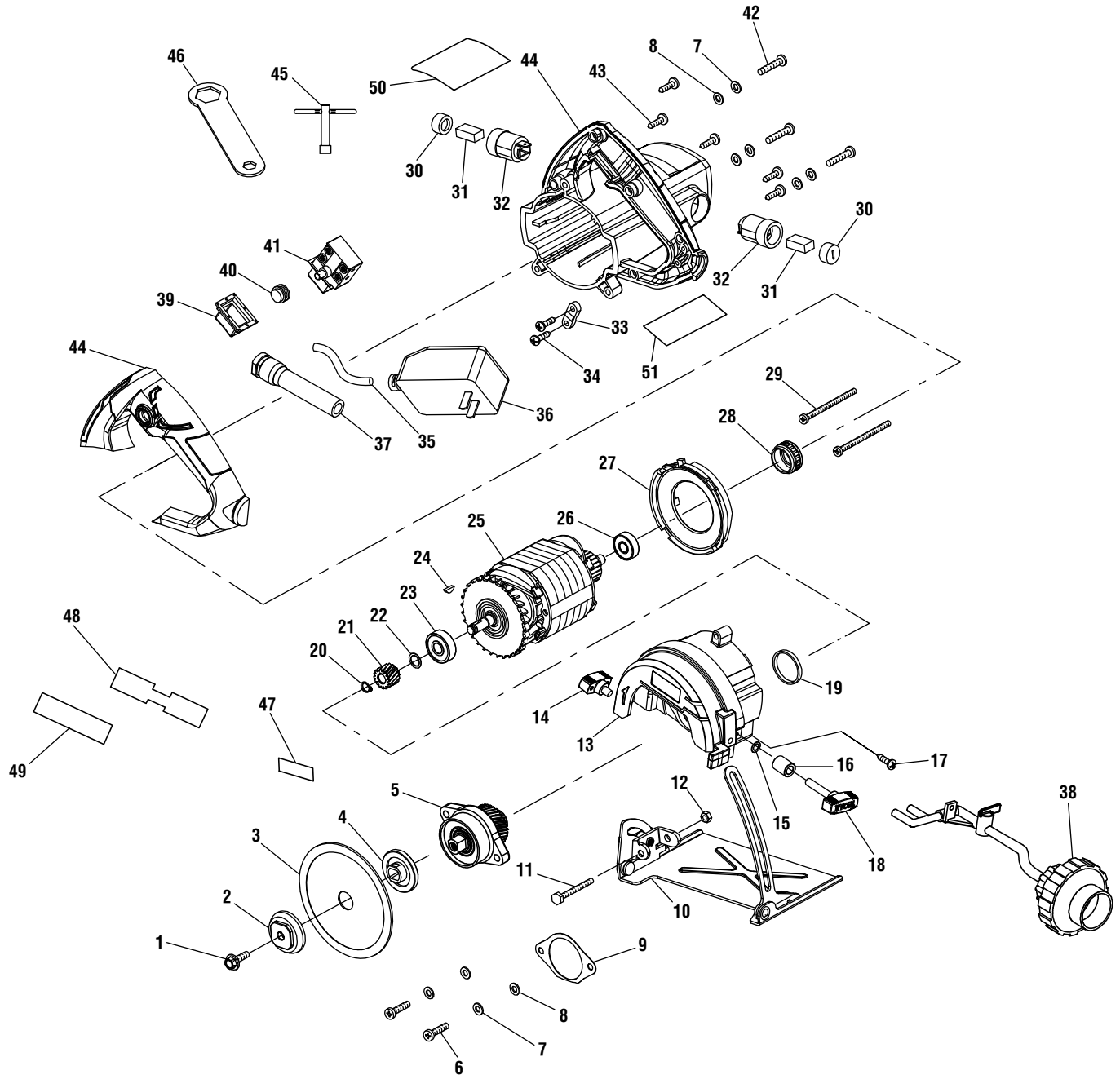

## RYOBI 4 in. WET/DRY TILE SAW – MODEL NUMBER TC401

The model number will be found on a label attached to the motor housing. Always mention the model number in all correspondence regarding your **4 in. WET/DRY TILE SAW** or when ordering parts.

### PARTS LIST

KEY NO.	PART NUMBER	DESCRIPTION	QTY	KEY NO.	PART NUMBER	DESCRIPTION	QTY
1	039815001001	Wheel Bolt (M6 x 18 mm, Special Left-Hand Threads) .....	1	28	039815001050	Bearing Sleeve .....	1
2	039815001002	Outer Wheel Washer .....	1	29	039815001052	Screw (M4.2 x 65 mm) .....	2
3	039815001003	Cutting Wheel (4 in.) .....	1	30	039815001044	Brush Cap .....	2
4	039815001004	Inner Wheel Bushing .....	1	31	039815001045	Brush With Spring .....	2
5	039815001009	Output Shaft Assembly .....	1	32	039815001046	Brush Holder .....	2
6	039815001005	Screw (M5 x 20 mm) .....	2	33	039815001055	Cord Clamp .....	1
7	039815001006	Lock Washer (ID5 x OD8.5 x 1.7t) .....	5	34	039815001054	Screw (M4.2 x 14 mm) .....	2
8	039815001007	Washer (ID5 x OD10 x 0.6t) .....	5	35	039815001047	Power Cord Assembly (Inc. Key Nos. 36-37) ..	1
9	039815001008	Gasket .....	1	36	039750001053	GFCI Plug Assembly .....	1
10	039815001025	Base Assembly .....	1	37	039815001048	Bend Relief .....	1
11	039815001024	Base Bolt (M5 x 40 mm) .....	1	38	039750001052	Water Supply System .....	1
12	039815001042	Base Nut (M5) .....	1	39	039815001056	Dust Cover (Switch) .....	1
13	039815001032	Upper Wheel Guard (Inc. Key No. 47) .....	1	40	039815001057	Lock On Button Cover .....	1
14	039815001031	Bevel Lock Knob .....	1	41	039815001058	Switch .....	1
15	039815001026	Washer (ID7 x OD13 x 0.8t) .....	1	42	039815001060	Screw (M5 x 25 mm) .....	3
16	039815001027	Steel Spacer .....	1	43	039815001059	Screw (M4.2 x 16 mm) .....	5
17	039815001029	Screw (M4 x 10 mm) .....	1	44	039815001020	Motor Housing Assembly .....	1
18	039815001028	Depth Lock Knob .....	1	45	039815001062	Hex T-Handle Wrench (11.5 mm) .....	1
19	039815001033	O-Ring (Ø26 x 3 mm) .....	1	46	039815001063	Hex Box Wrench (22 mm) .....	1
20	039815001035	Retaining Ring .....	1	47	941002145	Logo Label (Upper Guard) .....	1
21	039815001036	Pinion .....	1	48	941120087	Cord Warning Label .....	1
22	039815001037	Washer (ID8 x OD16 x 0.5t) .....	1	49	039750001054	GFCI Label .....	1
23	039815001038	Ball Bearing (629-2RS) .....	1	50	941121382	Data Label .....	1
24	039815001039	Key .....	1	51	941002146	Logo Label (Motor Housing) .....	1
25	039815001034	Motor Assembly (Inc. Key Nos. 23-24 and 26) .....	1	<b>Not Shown:</b>			
26	039815001041	Ball Bearing (608-2RS) .....	1	991000131	Operator's Manual (961152345)		
27	039815001051	Fan Baffle .....	1	9-26-14 (Rev:01)			

**RYOBI 4 in. WET/DRY TILE SAW – MODEL NUMBER TC401**

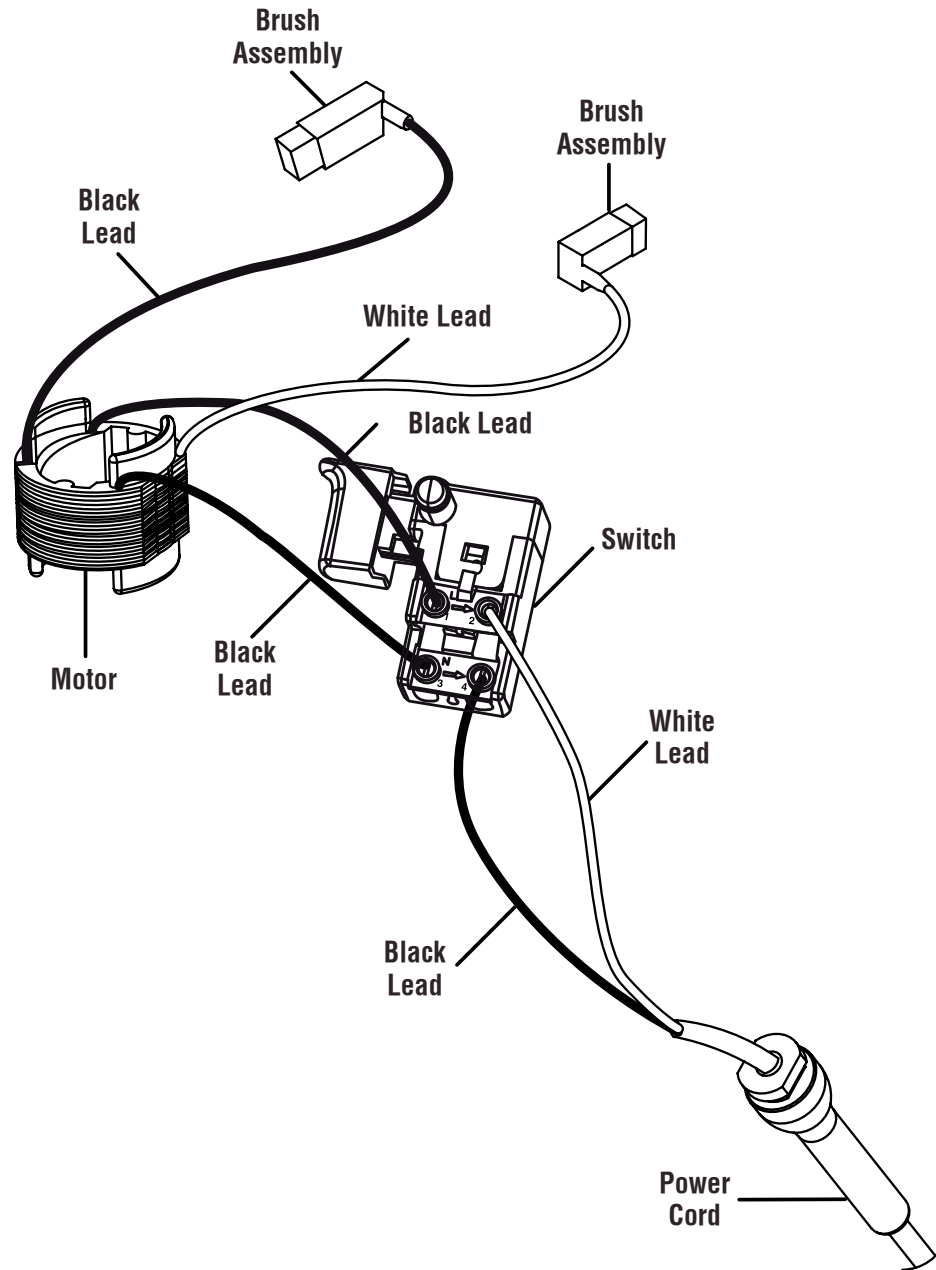

**WIRING DIAGRAM**