

# ST523

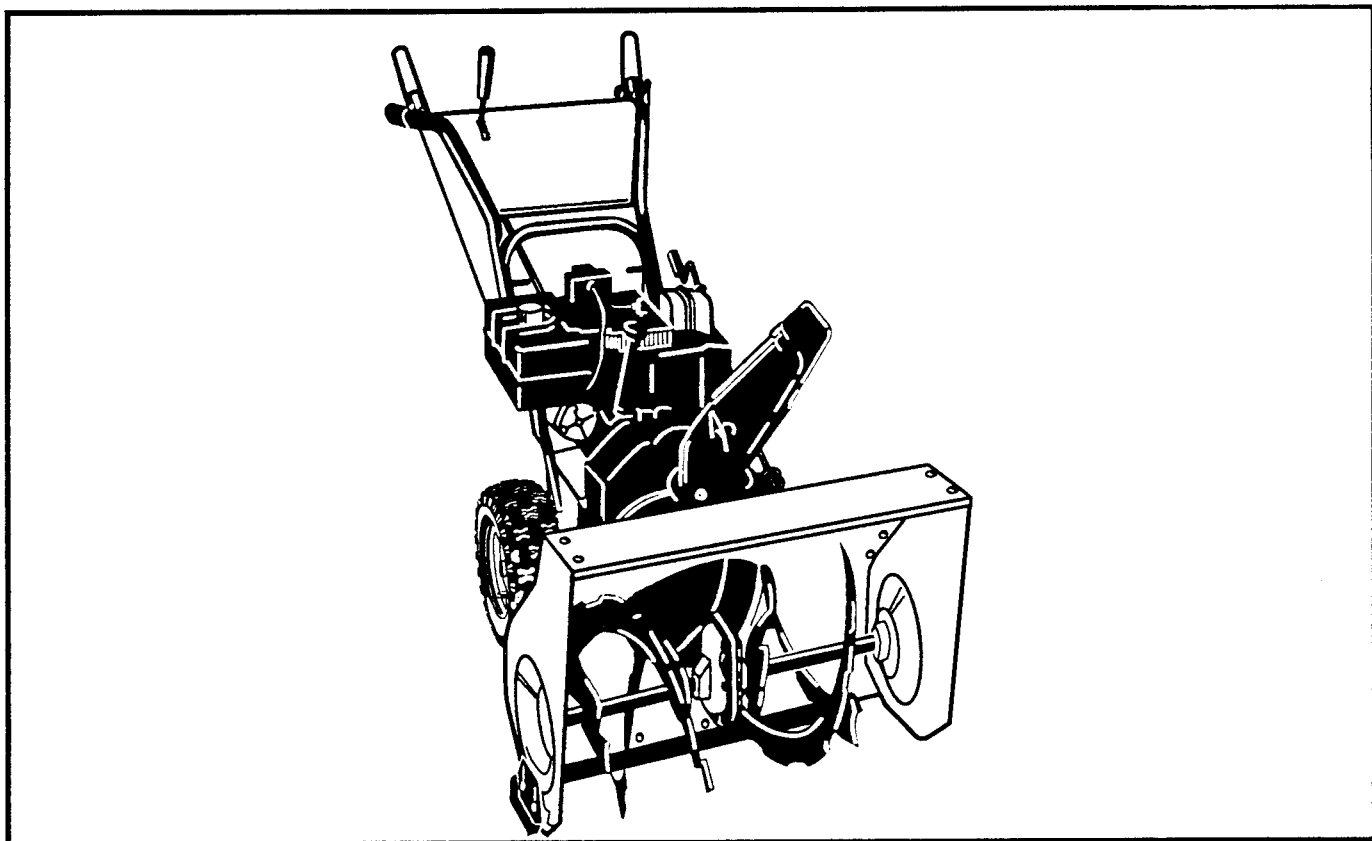

**1.1995**

**Spare Parts**

**Pièces Détachées**

# 23" SNOW THROWER MODEL ST 523

## ENGINE REPAIR PARTS

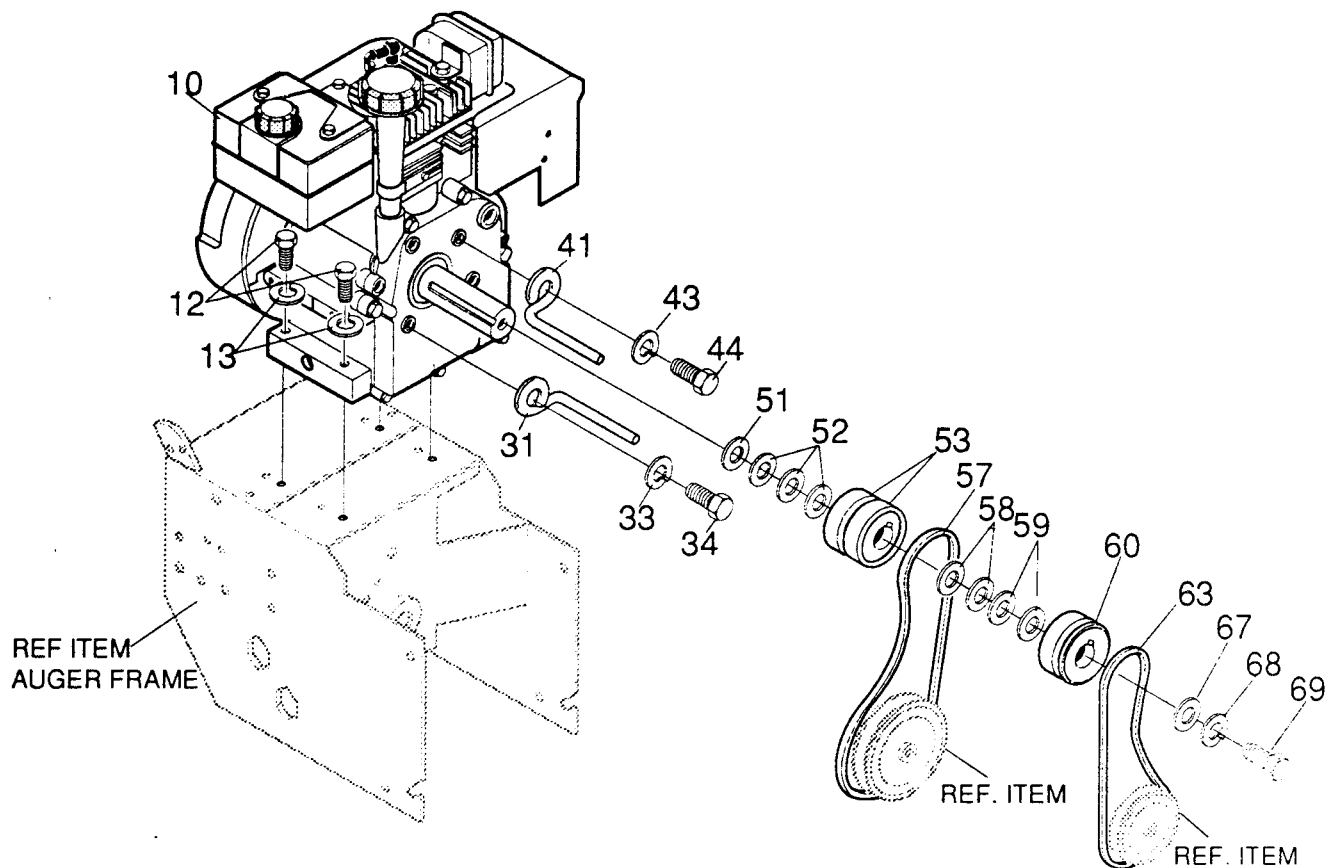

REF. NO.	PART NO.	PART NAME
10		ENGINE, 5 HP
12	601 00 14 31	SCREW, 5/16-18x1.25
13	601 00 00 23	WASHER, HVSP TLK .328x.60x.09
31	601 00 14 32	GUIDE, ROD BELT, RH
33	601 00 00 23	WASHER, HVSP TLK .328x.60x.09
34	601 00 14 33	SCREW, 5/16-24x.625 HHC
41	601 00 14 32	GUIDE, ROD BELT RH
43	601 00 00 23	WASHER, HVSP TLK .328x.60x.09
44	601 00 14 33	SCREW, 5/16-24x.625 HHC
51	601 00 14 34	WASHER, CRANKSHAFT
52	601 00 14 35	FLATWASHER, .752x.91x.02
53	601 00 14 36	PULLEY, HALF V3L 2.00x.752 ID
54	601 00 14 35	WASHER, FLAT .752x.91x.02
57	601 00 14 37	BELT, V 3L 33.13 LONG
58	601 00 14 38	FLATWASHER, .765x1.12x.06
59	601 00 14 35	FLATWASHER, .752x.91x.02
60	601 00 14 39	PULLEY, ENGINE V4L
63	601 00 14 40	BELT, V 4L AUG DRIVE 30.7
67	601 00 14 41	FLATWASHER
68	601 00 00 15	WASHER, REGSPTLK .393x.68x.10
69	601 00 05 27	SCREW, 3/8-24x1.00 NYL
	601 00 15 86	OWNER'S MANUAL

# 23" SNOW THROWER MODEL ST 523

## FRAME COMPONENTS REPAIR PARTS

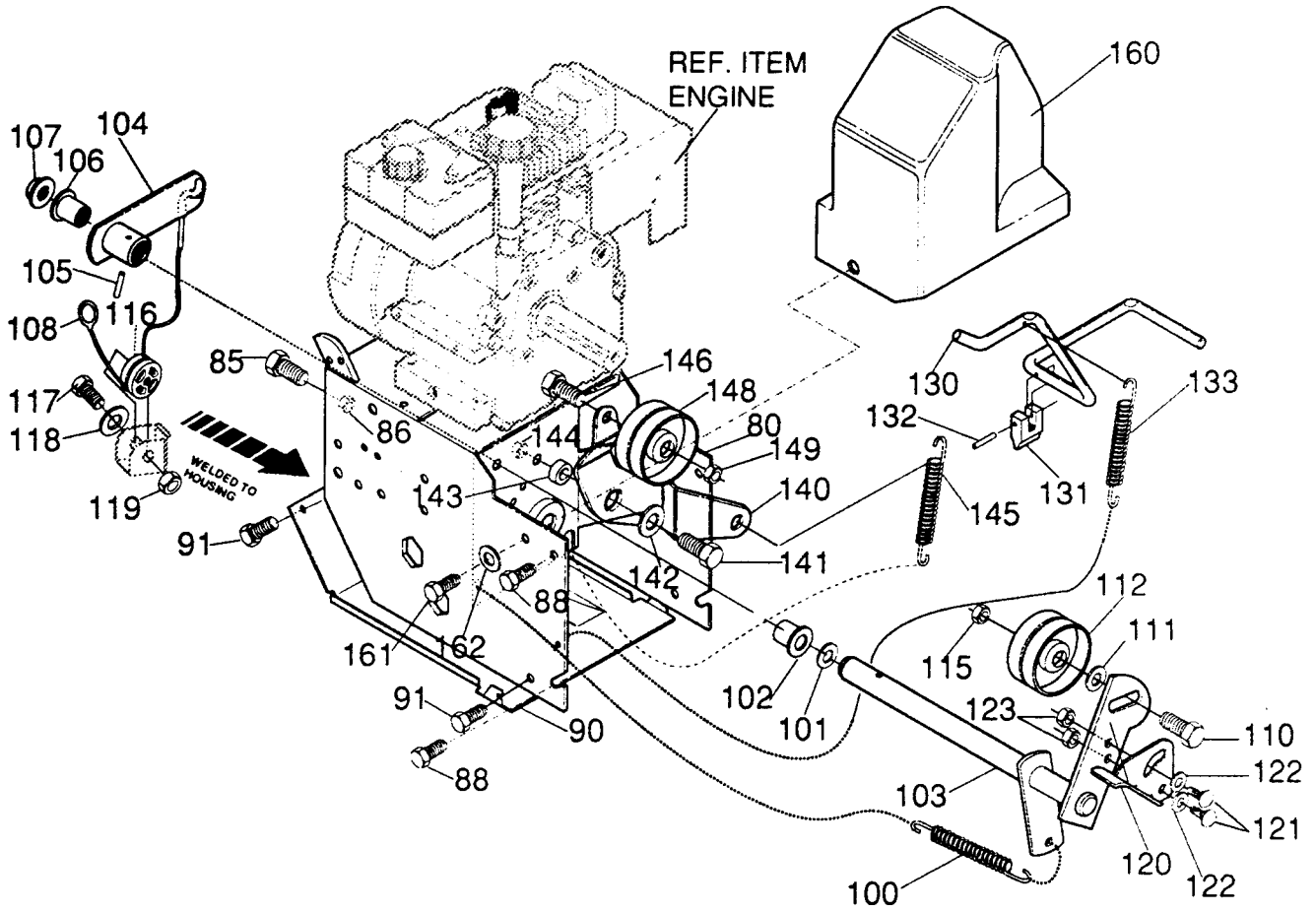

REF. NO.	PART NO.	PART NAME
80	601 00 14 42	FRAME, ASSY ENGINE MT 13"
85	601 00 14 43	SCREW, 5/16-24x1.00 HHC
86	601 00 08 23	NUT, 5/16-24 HEXWDFLLK
88	601 00 05 20	SCREW, 5/16-18x.75 WAHTAP
90	601 00 14 44	COVER, BOTTOM WHEEL DR
91	601 00 14 45	SCREW, 1/4-20x.63 WAHTAP
100	601 00 10 89	IDLER SPRING
101	601 00 14 46	FLATWASHER, .53x1.00x.063
102	601 00 14 47	BEARING, FLANGE
103	601 00 14 48	ASSY, SHAFT AUG CLUTCH
104	601 00 14 49	LEVER, ASSY AUGER CLUTCH CABLE
105	601 00 14 51	PIN, SPRING .165DIAx .88LG HD
106	601 00 14 47	BEARING, FLANGE
107	601 00 14 52	NUT, 1/2 PUSHON
108	601 00 14 53	CABLE, .205 EYE 6.125 LG
110	601 00 00 33	SCREW, 3/8-16x1.25
111	601 00 00 20	FLATWASHER, .406x.81x.065
112	601 00 14 54	PULLEY, IDLER
115	601 00 13 35	NUT, 3/8-16 HXCTRLKJAM
116	601 00 14 55	SPOOL, CABLE AUGER CLUTCH
117	601 00 14 56	SCREW, 1/4-20x1.75

REF. NO.	PART NO.	PART NAME
118	601 00 00 18	FLATWASHER, .281x.63x.065
119	601 00 00 62	NUT, 1/4-20 REGHEXCTRLK
120	601 00 14 50	CAM, BRAKE ARM
121	601 00 14 57	CARRIAGE BOLT, 1/4-20x.63
122	601 00 00 19	FLATWASHER, .344x.69x.065
123	601 00 00 62	NUT, 1/4-20 REGHEXCTRLK
130	601 00 14 58	BRAKE ROD
131	601 00 14 59	PAD, AUGER/IMPELLER BRAKE
132	601 00 14 51	PIN, SPRING.165 DIAx.88 LONG HD
133	601 00 14 60	SPRING, TENSION RETURN
140	601 00 14 61	LEVER, IDLER ARM TRACTION
141	601 00 00 73	SCREW, 5/16-18x.75
142	601 00 14 62	FLATWASHER, .328x1.38x.075
143	601 00 14 63	BUSHING, IDLER LEVER
144	601 00 14 64	NUT, 5/16-18 HEXNYL
145	601 00 10 89	SPRING, IDLER TRACTION DRIVE
146	601 00 00 33	SCREW, 3/8-16x1.25 HHC
148	601 00 14 54	PULLEY, IDLER BFF 1.88x.75
149	601 00 13 35	NUT, 3/8-16 HEXCTRLKJAM
160	601 00 14 65	COVER, BELT
161	601 00 06 68	SCREW, 1/4-20x.50 WAHTAP
162	601 00 00 18	FLATWASHER, .281x.63x.065

# 23" SNOW THROWER MODEL ST 523

## DRIVE COMPONENTS REPAIR PARTS

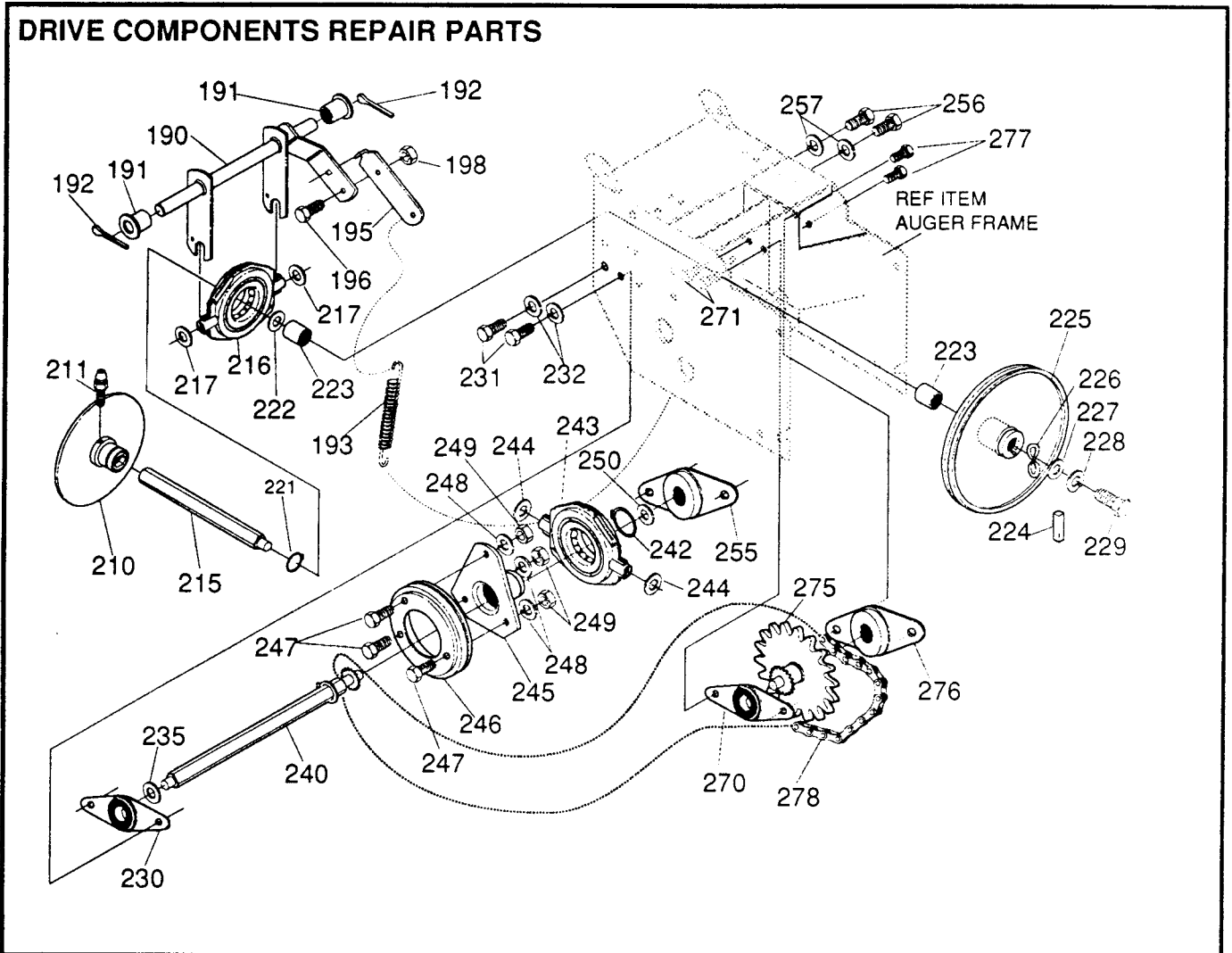

REF. NO.	PART NO.	PART NAME
190	601 00 14 66	LEVER, ASSY TRACT CLUTCH
191	601 00 14 47	BEARING, FLANGED
192	601 00 09 30	PIN, COTTER .125 DIAx1.00 LG
193	601 00 14 67	SPRING, RETURN
195	601 00 14 68	LEVER, SPRING TRAC CL
196	601 00 13 74	SCREW, 1/4-20x.63
198	601 00 00 62	NUT, 1/4-20 REGHEXCTRLK
210	601 00 14 69	DISC, ASSY FRICTION WHEEL
211	601 00 14 70	ZERK, GREASE .25-28x1.12 LONG
215	601 00 14 71	SHAFT, HEX TRACTION
216	601 00 14 72	BEARING, TRUNION 1.25 ID
217	601 00 14 73	FLATWASHER, .505x1.00x.06
221	601 00 14 74	RING, RETEX 1.16x.05
222	601 00 14 75	FLATWASHER, .680x1.12x.060
223	601 00 05 65	BEARING, BALL 6203-2AA
224	601 00 14 76	KEY, SQUARE .18 SQx.63 LONG
225	601 00 14 77	PULLEY, V3L 6.50x.56
226	601 00 14 78	WASHER, WAVE .675x1.00x.020
227	601 00 00 03	FLATWASHER, .281x1.00x.063
228	601 00 00 14	WASHER, SPTLK .263x.49x.07
229	601 00 00 68	SCREW, 1/4-20x.75
230	601 00 14 79	BEARING & RETAINER ASSY

REF. NO.	PART NO.	PART NAME
231	601 00 05 19	SCREW, 5/16-18x.50 WAHTAP
232	601 00 00 23	WASHER, SPTLK .328 X.60X.09
235	601 00 14 84	WASHER, SP .502X .75X.0605
240	601 00 14 81	SHAFT & SPRKT, ASSY #40-8T
242	601 00 14 74	RING, RETEX 1.16X.05
243	601 00 14 72	BEARING, TRUNION 1.25 ID
244	601 00 14 73	FLATWASHER, .505X1.00X.06
245	601 00 14 82	HUB, FRICTION WHEEL
246	601 00 14 83	WHEEL, FRICTION DISC 4.375 OD
247	601 00 13 34	SCREW, 1/4-20X .63
248	601 00 00 14	WASHER, SPTLK .26 X.50X.06
249	601 00 00 11	NUT, 1/4-20 REGHEX
250	601 00 14 84	WASHER, SP .502X .75X.0605
255	601 00 14 79	BEARING & RETAINER ASSY
256	601 00 05 19	SCREW, 5/16-18X .50
257	601 00 00 23	WASHER, SPTLK .328 X.60X.09
270	601 00 14 79	BEARING & RETAINER ASSY
271	601 00 05 19	SCREW, 5/16-18X .50
275	601 00 14 85	SPROCKET, ASSY 8T & 36T-41
276	601 00 14 79	BEARING & RETAINER ASSY
277	601 00 05 19	SCREW, 5/16-18X .50
278	601 00 14 86	CHAIN, ROLLER #42x40

# 23" SNOW THROWER MODEL ST 523

## GEAR BOX REPAIR PARTS

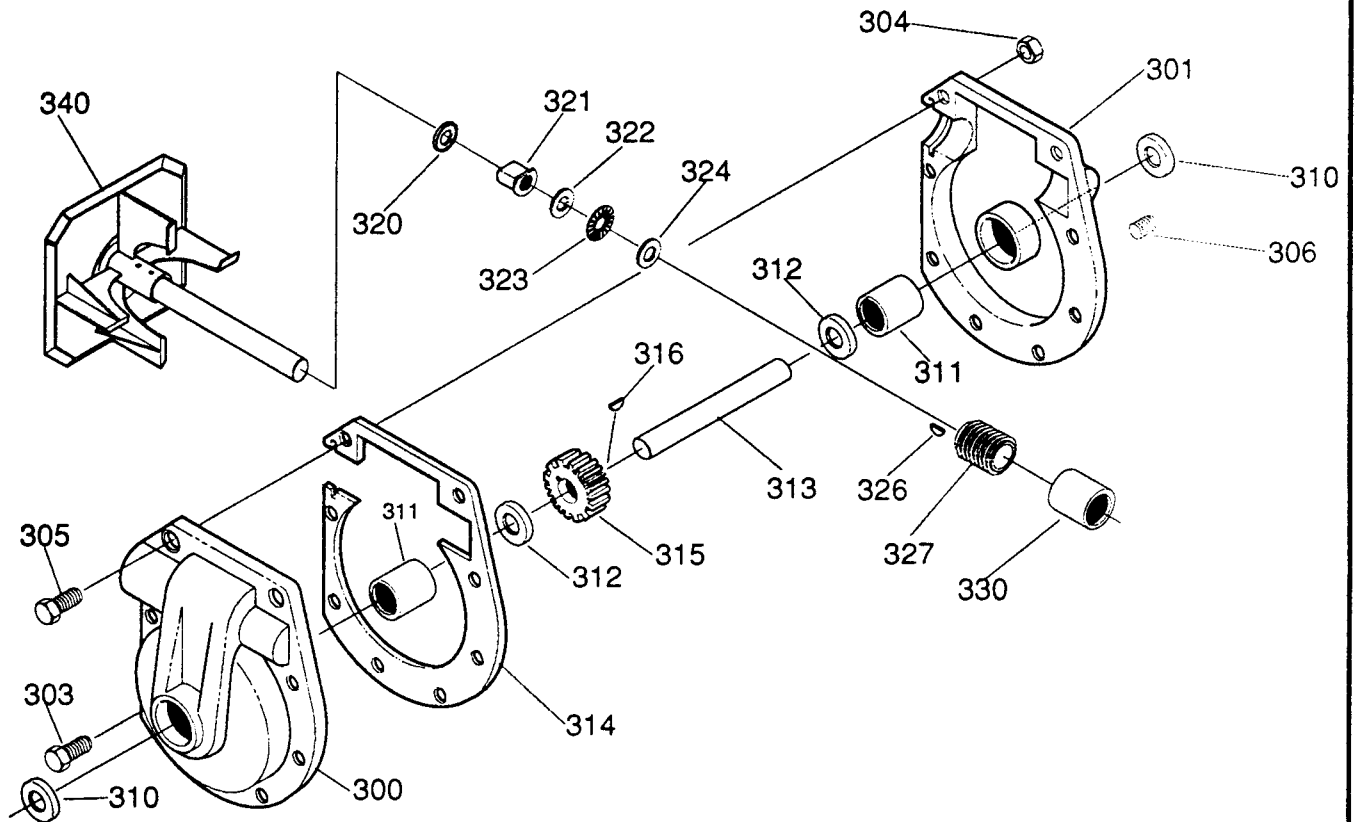

REF. NO.	PART NO.	PART NAME
300	601 00 14 87	CASE, GEAR, RH
301	601 00 14 88	CASE, GEAR, LH
303	601 00 14 43	SCREW, 5/16-24x1.00 HHC
304	601 00 08 23	NUT, 5/16-24 HEXWDFLLK
305	601 00 14 89	SCREW, 5/16-24x1.50 HHC
306	601 00 14 90	PIPE PLUG
310	601 00 14 91	SEAL, OIL CR 530552 #53744
311	601 00 14 92	BEARING, SLEEVE
312	601 00 14 93	FLATWASHER
313	601 00 14 94	SHAFT, AUGER OUTPUT MF 22"
314	601 00 14 95	GASKET, GEAR BOX
315	601 00 14 96	WORM GEAR
316	601 00 14 97	KEY, WDRF #91 .75 DIAx.25 WD
320	601 00 14 98	RING, QUAD
321	601 00 14 99	BEARING, FL .753 IDx1.128 ODx1.03
322	601 00 15 00	FLATWASHER, .752x1.24x.093 PL
323	601 00 15 01	BEARING, ROLL
324	601 00 15 00	FLATWASHER, .752x1.24x.093 PL
326	601 00 15 02	KEY, HI-PRO 606 .75DIAx.187WD
327	601 00 15 03	WORM GEAR
330	601 00 15 04	BEARING, SLEEVE .752 IDx.88 ODx.755
580	601 00 15 05	IMPELLER ASSEMBLY

314014 C

# 23" SNOW THROWER MODEL ST 523

## AUGER HOUSING REPAIR PARTS

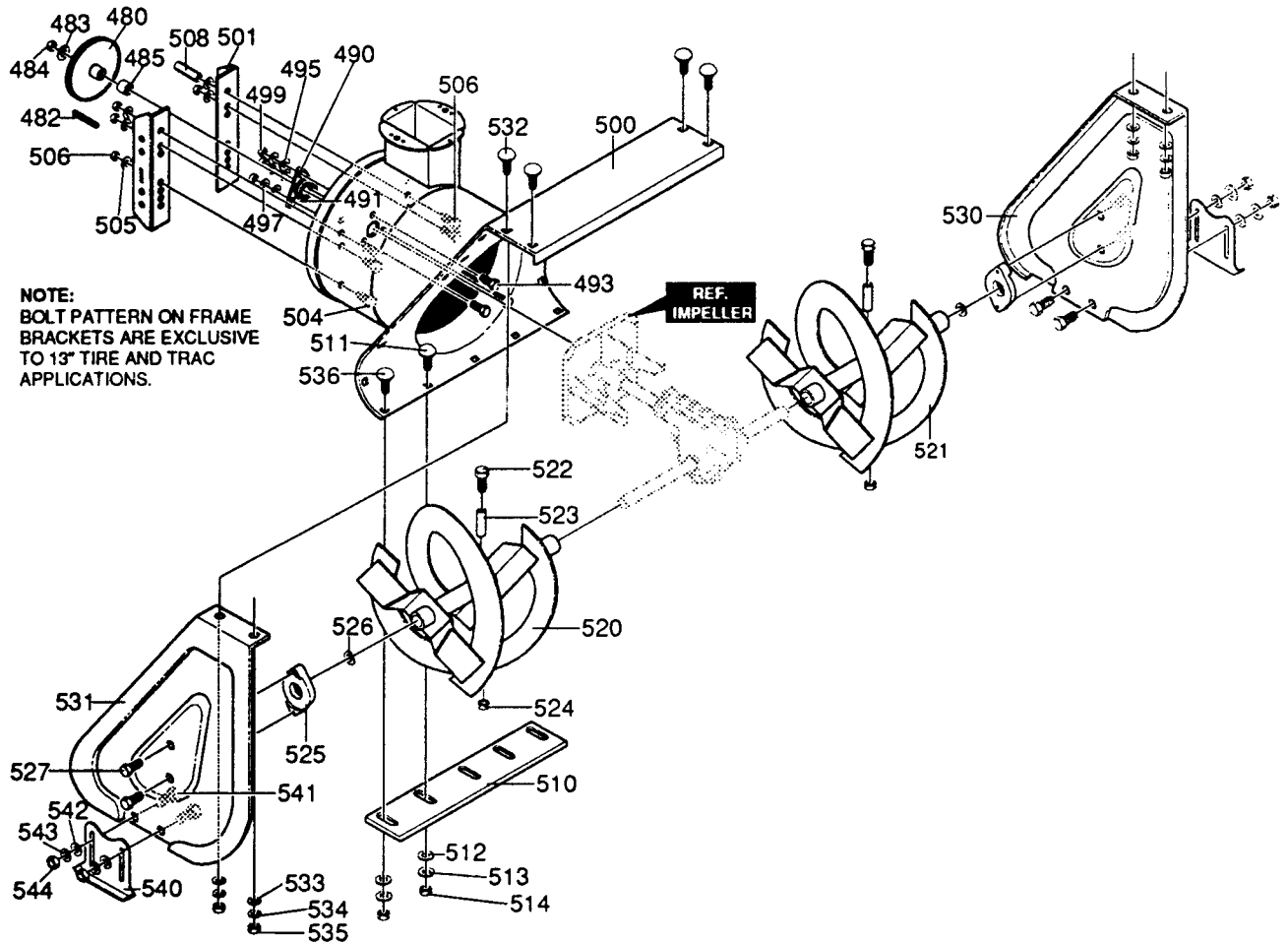

NOTE:  
BOLT PATTERN ON FRAME  
BRACKETS ARE EXCLUSIVE  
TO 13" TIRE AND TRAC  
APPLICATIONS.

REF. NO.	PART NO.	PART NAME
480	601 00 15 06	PULLEY, V4L 6.50 OD
482	601 00 15 07	KEY, SQUARE .18 SQx.88 LG
483	601 00 14 46	FLATWASHER, .53x1.00x.063
484	601 00 01 07	NUT, 1/2-20 REGHXCTRLK
485	601 00 15 08	SPACER, SLEV .676x1.00x.751
490	601 00 15 09	RETAINER, BALL BRNG
491	601 00 05 65	BRNG, BALL 6203-2AA(SEALS)-C3
493	601 00 00 73	SCREW, 5/16-18x.88 HHC
495	601 00 00 19	FLATWASHER, .344x.69x.065
497	601 00 00 23	WASHER, HVSP TLK .328x.60x.09
499	601 00 00 12	NUT, 5/16-18 REGHEX
500	601 00 15 10	HOUSING, ASSY
501	601 00 15 11	BRACKET & NUTS ASSY
504	601 00 15 12	SCREW 3/8-16x.75
505	601 00 00 15	WASHER .393x.68x.10
506	601 00 00 60	NUT, 3/8-16 REGHEXCTRLK
508	601 00 15 13	HUB, BRAKE ARM
510	601 00 15 14	BLADE, SCRAPER, MF 24"
511	601 00 14 11	BOLT, 5/16-18x.75 CARRLN
512	601 00 00 19	FLATWASHER, .344x.69x.065
513	601 00 00 23	WASHER, HVSP TLK .328x.60x.09

REF. NO.	PART NO.	PART NAME
514	601 00 00 12	NUT, 5/16-18 REGHEX
520	601 00 15 15	AUGER, ASSY MF LH 22"
521	601 00 15 16	AUGER, ASSY MF RH 22"
522	601 00 14 56	SCREW, 1/4-20x1.75 HHCFT
523	601 00 15 17	SPACER, SLEV .250x.47x.20
524	601 00 00 62	NUT, 1/4-20 REGHEXCTRLK
525	601 00 15 18	AUGER SHAFT BEARING
526	601 00 15 19	FLATWASHER, 1.005x1.31x.035
527	601 00 05 20	SCREW, 5/16-18x.75 WAHTAP
530	601 00 15 20	PLATE, AUGER HSNG END, LH
531	601 00 15 21	PLATE, AUGER HSNG END, RH
532	601 00 14 11	BOLT, 5/16-18x.75 CARRLN
533	601 00 00 19	FLATWASHER, .344x.69x.065
534	601 00 00 23	WASHER, HVSP TLK .328x.60x.09
535	601 00 00 12	NUT, 5/16-18 REGHEX
536	601 00 08 99	BOLT, 5/16-18x1.00 CARRLN
540	601 00 15 22	SKID, HEIGHT ADJUST
541	601 00 14 11	BOLT, 5/16-18x.75 CARRLN GR2
542	601 00 00 19	FLATWASHER, .344x.69x.065
543	601 00 00 23	WASHER, HVSP TLK .328x.60x.09
544	601 00 00 12	NUT, 5/16-18 REGHEX

334396 A



# 23" SNOW THROWER MODEL ST 523

## WHEEL ASSEMBLY REPAIR PARTS

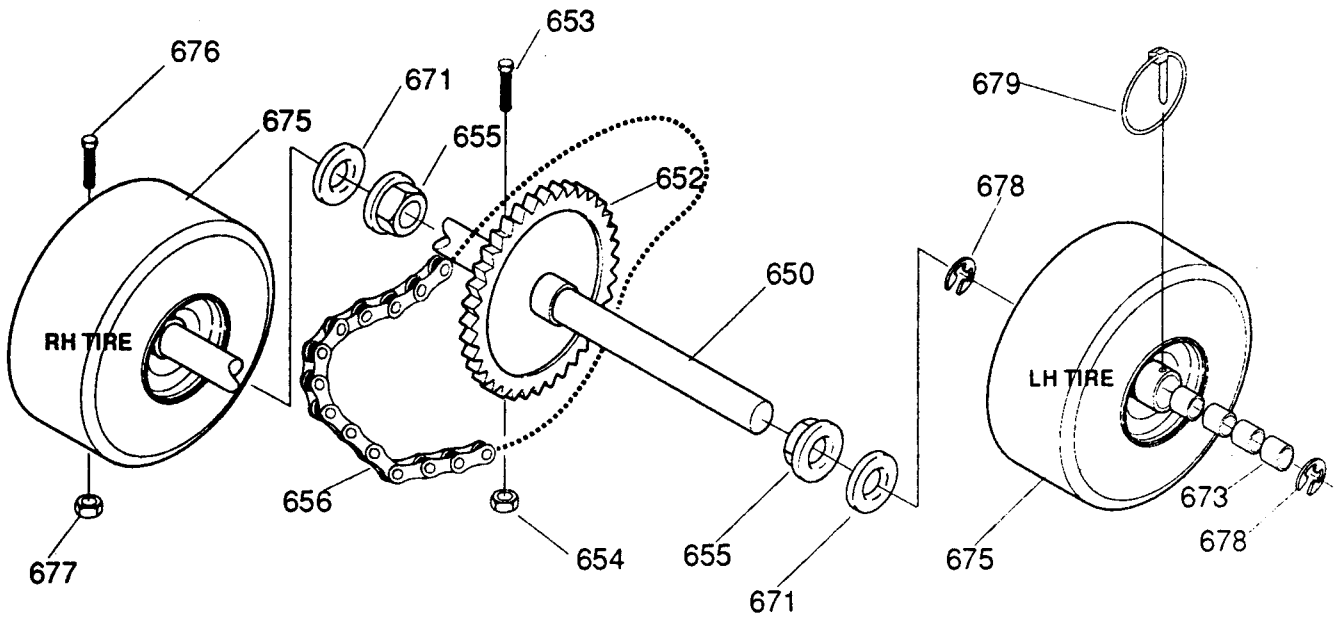

REF. NO.	PART NO.	PART NAME
650	601 00 15 33	SHAFT, AXLE
652	601 00 15 34	SPRKT, HUB #40-35Tx .75ID
653	601 00 15 35	SCREW, 1/4-20x2.25
654	601 00 00 62	NUT, 1/4-20 REGHEXCTRLK
655	601 00 15 36	BEARING, FL .755IDx1.127ODx .75
656	601 00 14 86	CHAIN, ROLLER #42x40PITCHES
671	601 00 14 38	FLATWASHER, .765x1.12x.06
673	601 00 15 37	BEARING, FLANGE
675	601 00 15 38	TIRE & RIM, PU 13x5.0x6
676	601 00 15 39	SCREW, SHR 1/4-20x1.75
677	601 00 00 62	NUT, 1/4-20 REGHEXCTRLK
678	601 00 15 40	RING, RET
679	601 00 15 41	PIN, KLIK .25x1.38 DIA



# 23" SNOW THROWER MODEL ST 523

## HANDLE CONTROL REPAIR PARTS

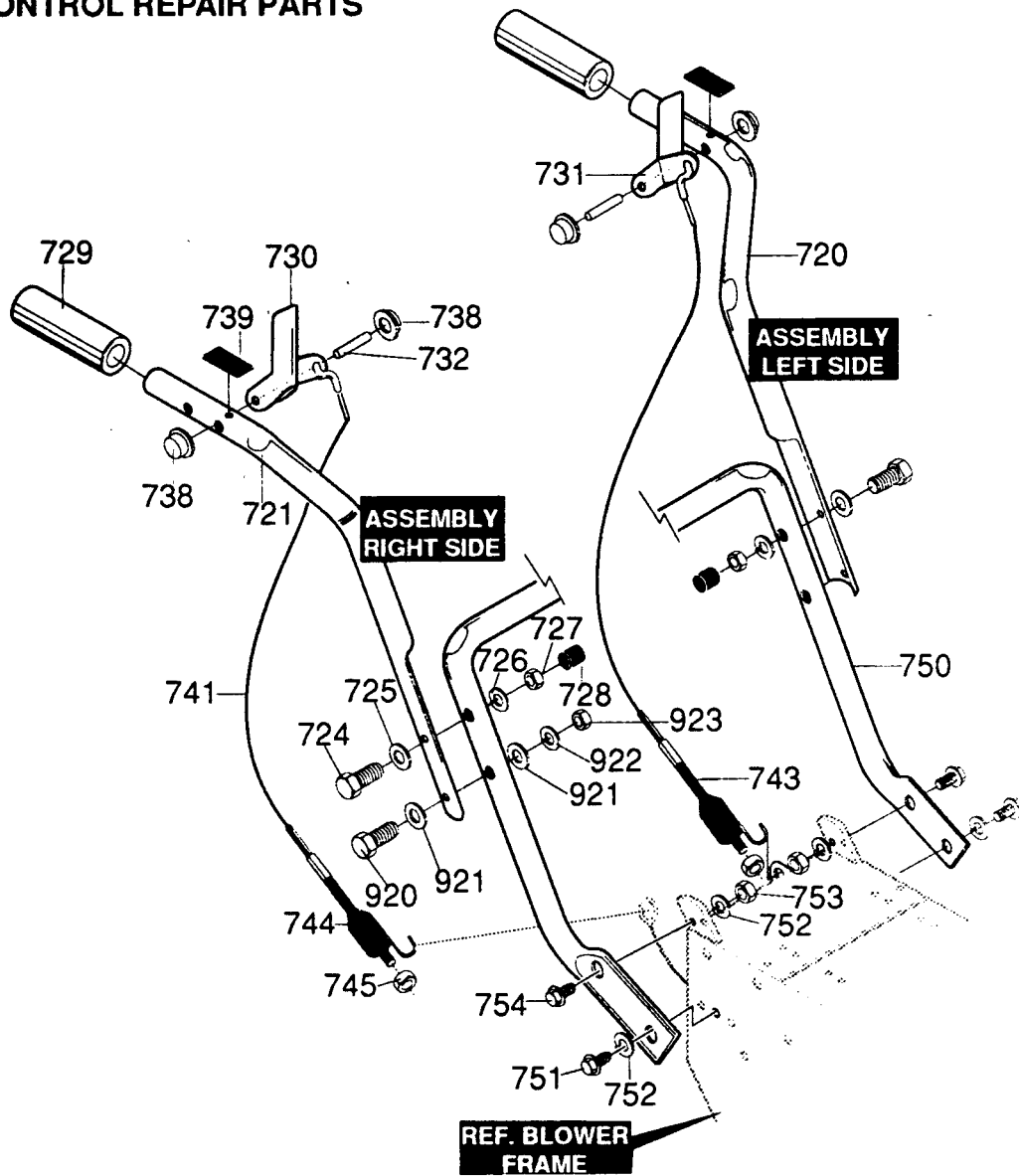

REF. NO.	PART NO.	PART NAME
720	601 00 15 42	HANDLE, UPPER, LH
721	601 00 15 43	HANDLE, UPPER, RH
724	601 00 15 44	SCREW, 3/8-16x3.00 HHCFT
725	601 00 00 20	FLATWASHER, .406x.81x.065
726	601 00 00 15	WASHER, REGSPTLK .393x.68x.10
727	601 00 00 60	NUT, 3/8-16 REGHXCTRLK
728	601 00 15 45	STOP, PLASTIC .375
729	601 00 15 46	GRIP, HANDLE 1.25x4.38
730	601 00 15 47	HANDLE, RH ASSEMBLY
731	601 00 15 48	HANDLE, LH ASSEMBLY
732	601 00 15 49	PIN, PIVOT .31 OD
738	601 00 05 16	NUT, PUSH ON CAP .312 OD
739	601 00 15 50	BUMPER, RECT W/FLAT TOP

REF. NO.	PART NO.	PART NAME
741	601 00 15 51	CABLE, CLUTCH 32.19" TRACTION
743	601 00 15 52	SPRING TENSION
744	601 00 15 53	SPRING, AUGER CLUTCH
745	601 00 00 62	NUT, 1/4-20 REGHEXCTRLK
750	601 00 15 54	HANDLE, LOWER
751	601 00 00 73	SCREW, 5/16-18x.75 HHC
752	601 00 00 23	WASHER, HVSPTLK .328x.60x.09
753	601 00 00 12	NUT, 5/16-18 REGHEX
754	601 00 05 20	SCREW, 5/16-18x.75 WAHTAP
920	601 00 15 55	SCREW, 3/8-16x2.00 HHC
921	601 00 00 20	FLATWASHER, .406x.81x.065
922	601 00 00 15	WASHER, REGSPTLK .393x.68x.10
923	601 00 00 60	NUT, 3/8-16 REGHEXCTRLK

# 23" SNOW THROWER MODEL ST 523

## CONTROL PANEL REPAIR PARTS

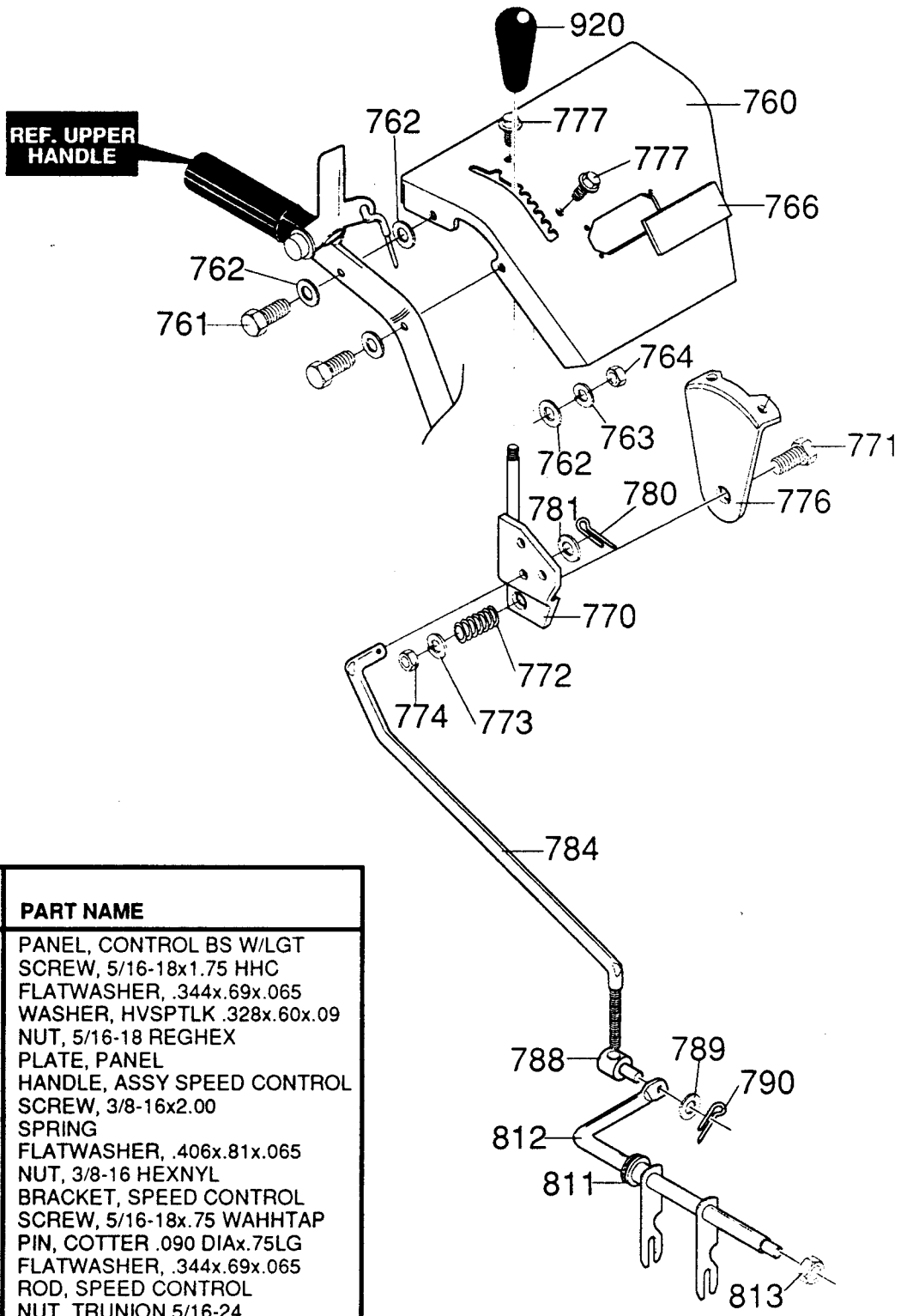

REF. NO.	PART NO.	PART NAME
760	601 00 15 56	PANEL, CONTROL BS W/LGT
761	601 00 15 57	SCREW, 5/16-18x1.75 HHC
762	601 00 00 19	FLATWASHER, .344x.69x.065
763	601 00 00 23	WASHER, HVSP TLK .328x.60x.09
764	601 00 00 12	NUT, 5/16-18 REG HEX
766	601 00 15 58	PLATE, PANEL
770	601 00 15 59	HANDLE, ASSY SPEED CONTROL
771	601 00 15 55	SCREW, 3/8-16x2.00
772	601 00 15 60	SPRING
773	601 00 00 20	FLATWASHER, .406x.81x.065
774	601 00 06 53	NUT, 3/8-16 HEX NYL
776	601 00 15 61	BRACKET, SPEED CONTROL
777	601 00 05 20	SCREW, 5/16-18x.75 WAHTAP
780	601 00 00 25	PIN, COTTER .090 DIAx.75LG
781	601 00 00 19	FLATWASHER, .344x.69x.065
784	601 00 15 62	ROD, SPEED CONTROL
788	601 00 15 63	NUT, TRUNION 5/16-24
789	601 00 00 19	FLATWASHER, .344x.69x.065
790	601 00 00 25	PIN, COTTER .090 DIAx.75 LONG
811	601 00 15 64	BEARING, FL .500 IDx.88 ODx.31
812	601 00 15 65	ROD, ASM SPEED CONSOLE
813	601 00 00 60	NUT, 3/8-16 REGHXCTRLK
920	601 00 15 66	KNOB, 3/8-16x.75

# 23" SNOW THROWER MODEL ST 523

## CHUTE CONTROL ROD REPAIR PARTS

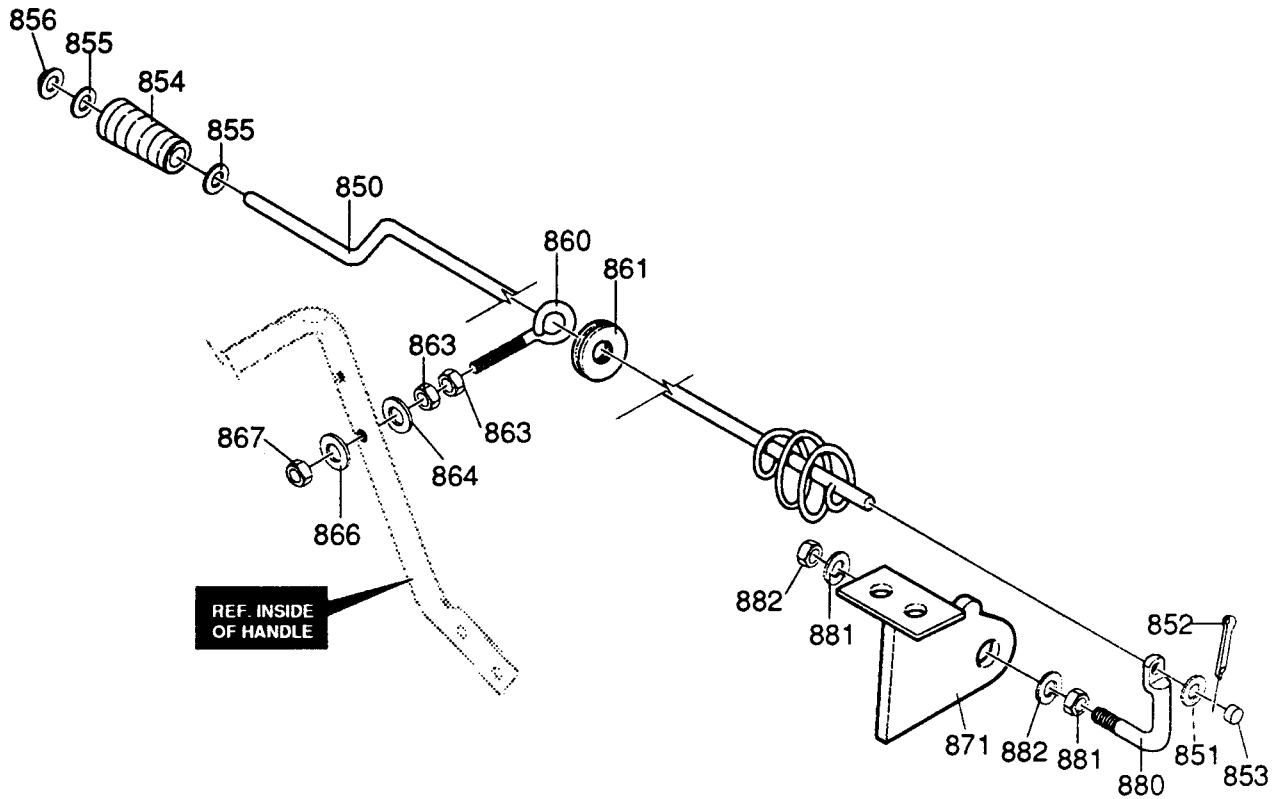

REF. NO.	PART NO.	PART NAME
850	601 00 15 67	CRANK, ASSY CHUTE
851	601 00 00 20	FLATWASHER, .406x.81x.065
852	601 00 14 03	PIN, COTTER .094 DIAx1.00 LONG
853	601 00 15 68	CAP, PLASTIC, 3/8 ID
854	601 00 15 69	KNOB, SLEEVE
855	601 00 00 20	FLATWASHER, .406x.81x.065
856	601 00 12 91	NUT, PUSH ON 3/8"
860	601 00 15 70	BOLT, EYE 3/8-16x5.00 .63ID
861	601 00 14 08	GROMMET, EYE BOLT.40IDx.435WD
863	601 00 14 09	NUT, 3/8-16 HEXJAM
864	601 00 00 20	FLATWASHER, .406x.81x.065
866	601 00 00 20	FLATWASHER, .406x.81x.065
867	601 00 06 53	NUT, 3/8-16 HEXNYL
871	601 00 15 71	PLATE, ASSY MTG STL CHUTE
880	601 00 15 72	ROD, CHUTE CONT 420T
881	601 00 15 73	NUT, 1/2-20 HXJAM
882	601 00 15 74	WASHER, REGSPTLK .523x.87x.14

# 23" SNOW THROWER MODEL ST 523

## DECALS

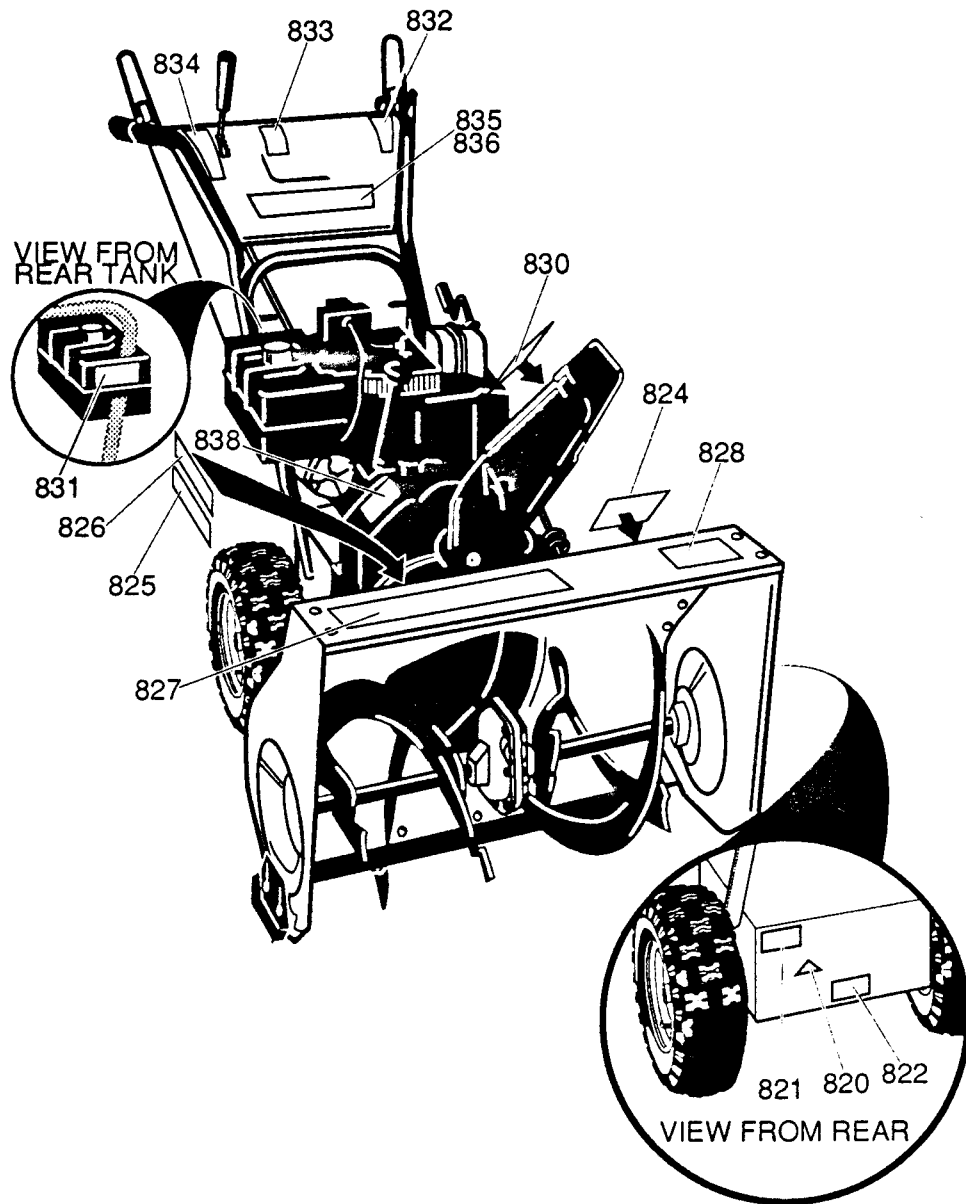

REF. NO.	PART NO.	PART NAME
820		REFERENCE ONLY
821		REFERENCE ONLY
822	601 00 15 75	DECAL, OVER ADJ OF DISC
824	601 00 15 76	DECAL, DANGER FOOT SYM
825	601 00 15 77	DECAL, DUAL STAGE
827	601 00 15 78	DECAL, 5HP-24" PATH NOMA
830	601 00 15 79	DECAL, DANGER FINGER
831	601 00 15 80	DECAL, IMPORTANT FREE IMPEL
832	601 00 15 81	DECAL, TRACTION DRIVE #6099
833	601 00 15 82	DECAL, SNOW CONDITIONS
834	601 00 15 83	DECAL, GEAR SELECTOR/AUGER
835	601 00 15 84	DECAL, NOMA SNOWTHROWER PANEL
838	601 00 15 85	DECAL, BELT ADJ