

RYOBI
40 Volt Hedge Trimmer
Model No. RY40602
Mfg. No. 107273001
Repair Sheet

RYOBI 40 VOLT HEDGE TRIMMER – MODEL NO. RY40602

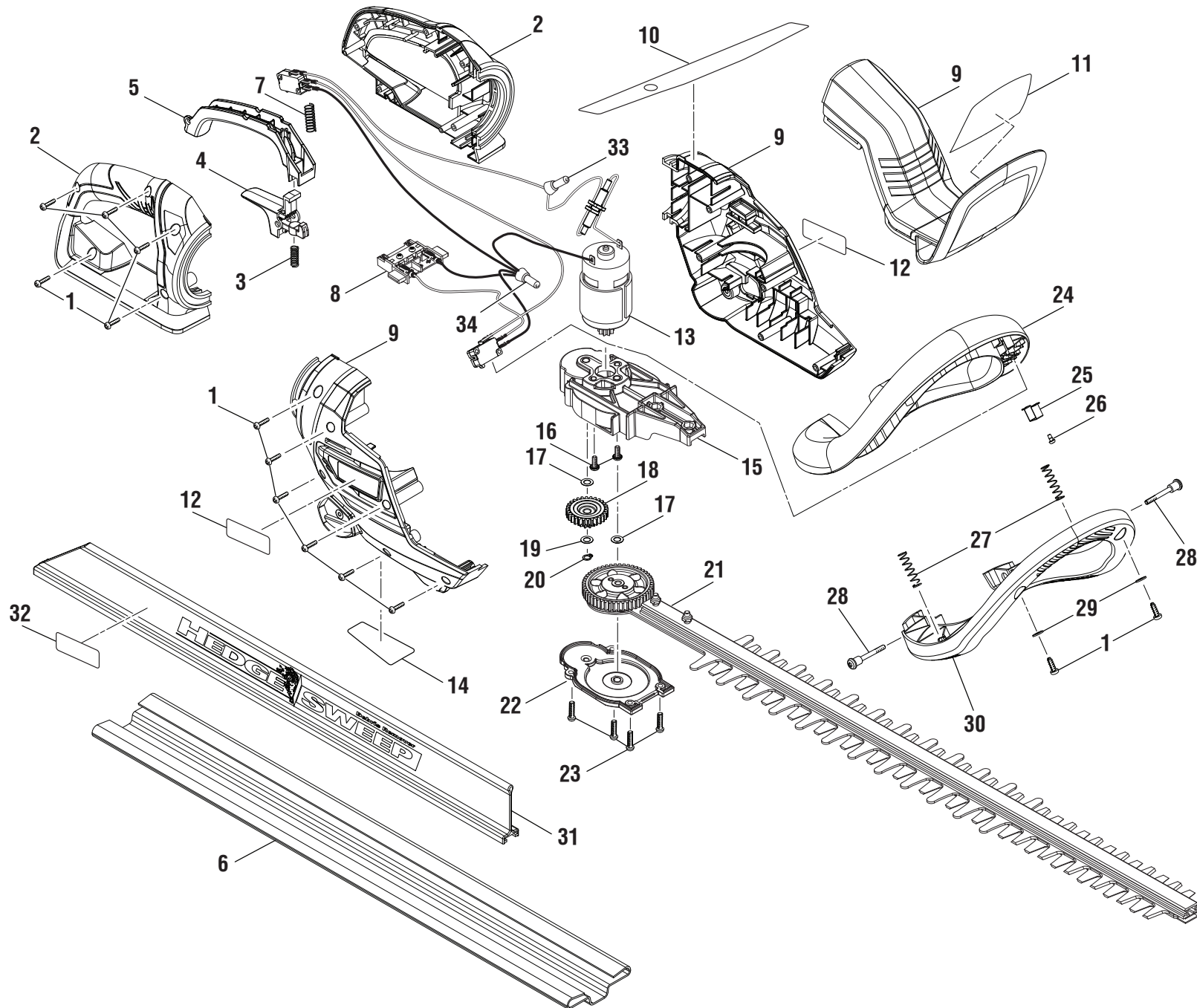

RYOBI 40 VOLT HEDGE TRIMMER – MODEL NO. RY40602

The model number will be found on a label attached to the motor housing. Always mention the model number in all correspondence regarding your Hedge Trimmer or when ordering replacement parts.

PARTS LIST

KEY NO.	PART NUMBER	DESCRIPTION	QTY	KEY NO.	PART NUMBER	DESCRIPTION	QTY
1	661817002	Screw (M4 x 13.5 mm, T15 Torx Pan Hd.).....	13	19	638623005	Washer (OD10 x 5.3ID x 0.5t)	1
2	205094001	Rear Handle Assembly	1	20	679048001	Retaining Ring.....	1
3	695164001	Compression Spring	1	21	205096001	Blade Assembly (24 in.).....	1
4	311716001	Lock-off Trigger Assembly	1	22	535297001	Gear Case Cover	1
5	529765001	Trigger	1	23	660208052	Screw (M4 x 16 mm, Pan Hd.).....	4
6	528341001	Scabbard.....	1	24	526800001	Front Handle	1
7	679055008	Compression Spring	1	25	639109001	Switch Bracket	1
8	205100001	Switch and Contact Plate Assembly (Inc. Key Nos. 13 and 33-34).....	1	26	660203073	Screw (M3 x 6 mm, Pan Hd.)	1
9	205095001	Motor Housing Assembly (Inc. Key Nos. 10-12 & 14)	1	27	679055009	Compression Spring	2
10	941589008	Angle Adjustment Label.....	1	28	660137014	Screw (M4 x 38 mm, T20 Torx Pan Hd.)	2
11	941589006	Warning Label	1	29	690969001	Washer (OD10 x ID4.2 x 1t)	2
12	941589005	Logo Label	2	30	526801001	Front Handle Cover	1
13	205099001	Motor Assembly	1	31	205101001	Hedge Sweep (Inc. Key No. 32).....	1
14	941589007	Data Label	1	32	941769001	Warning Label	1
15	535298001	Gear Case	1	33	790009004	Wire Connector	1
16	660137001	Screw w/Lock Washer (M4 x 12 mm, Pan Hd.).....	2	34	790021001	Wire Connector	1
17	670914001	Washer (M6)	2	Not Shown:			
18	312379001	Middle Gear Assembly	1	995000583 Operator's Manual			
				5-8-19			
				(Rev:04)			

RYOBI 40 VOLT HEDGE TRIMMER – MODEL NO. RY40602

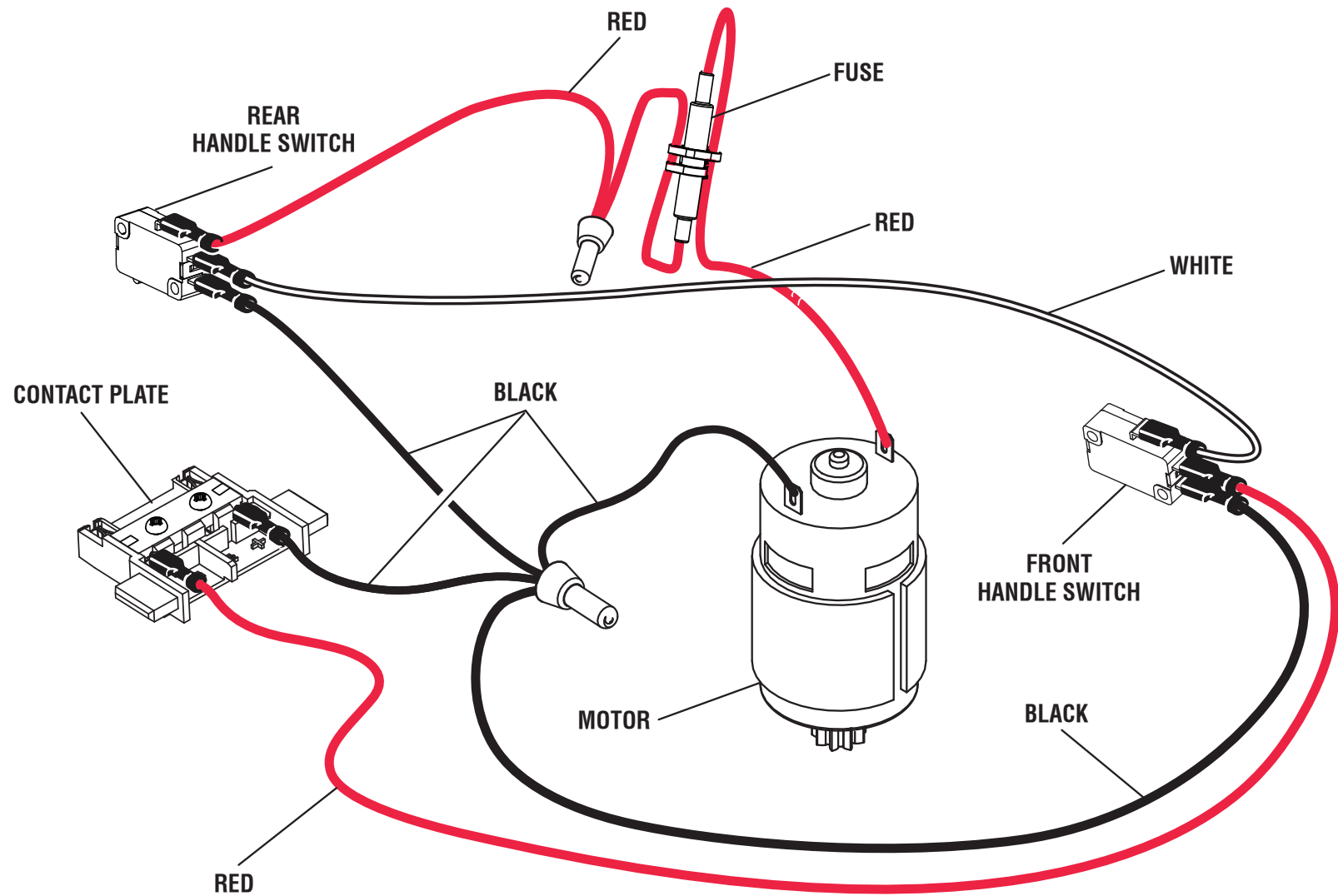

WIRING DIAGRAM