

RYOBI 40 VOLT HEDGE TRIMMER – MODEL NUMBER RY40600

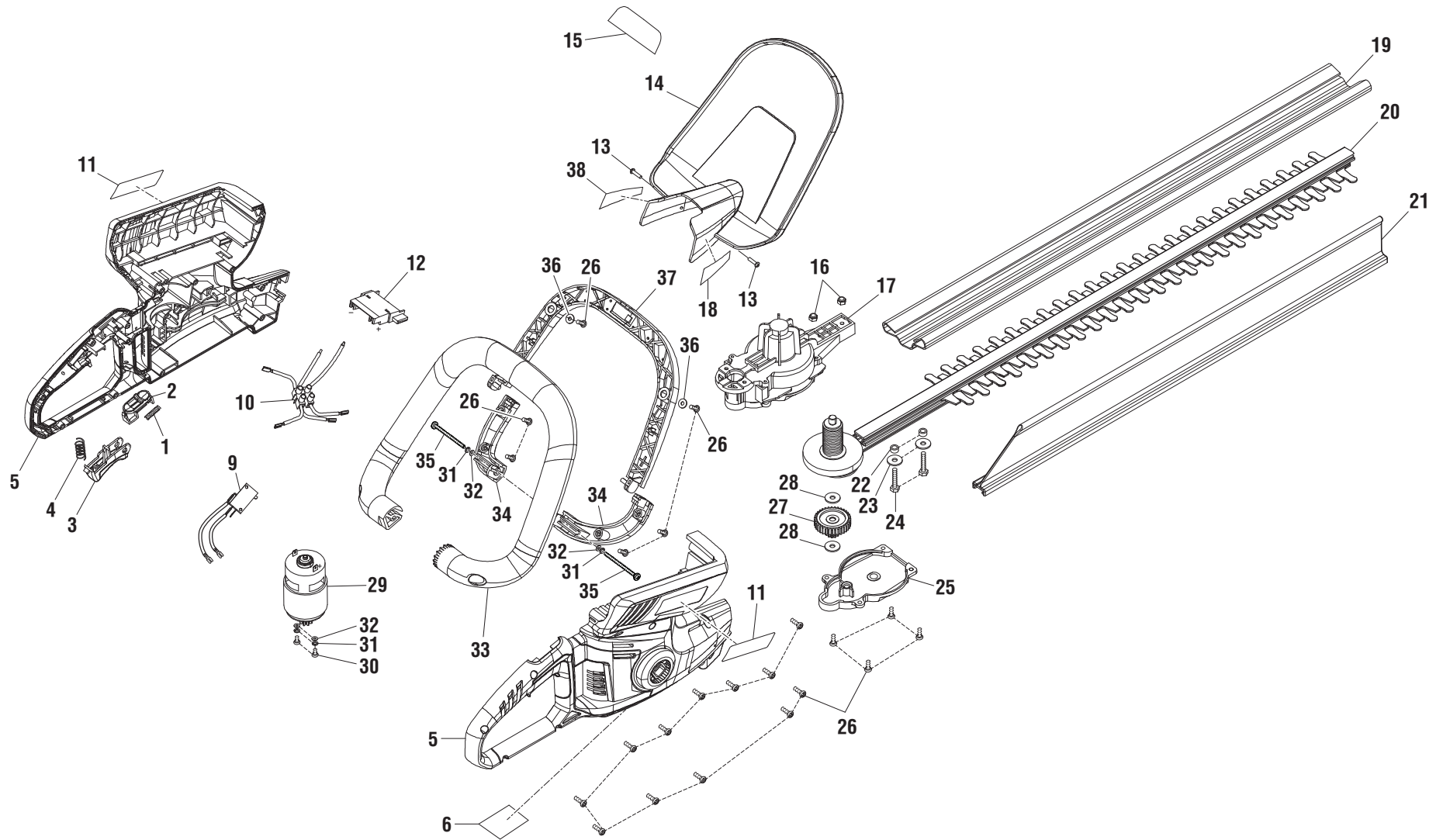

RYOBI 40 VOLT HEDGE TRIMMER – MODEL NUMBER RY40600

The model number will be found on a label attached to the motor housing. Always mention the model number in all correspondence regarding your **HEDGE TRIMMER** or when ordering repair parts.

PARTS LIST

KEY NO.	PART NUMBER	DESCRIPTION	QTY	KEY NO.	PART NUMBER	DESCRIPTION	QTY
1	099968002001	Compression Spring.....	1	23	33321442G	Washer (OD16 x ID5.2 x 1.5t).....	2
2	099968002002	Lock Off Button	1	24	33202639G	Screw (M5 x 30 mm).....	2
3	099968002003	Trigger.....	1	25	34108454G	Gear Box Cover.....	1
4	099968002004	Compression Spring.....	1	26	099968002026	Screw (M4 x 12 mm).....	22
5	31111650G	Housing Assembly.....	1	27	33904454G	Dual Gear.....	1
6	941588019	Data Label	1	28	3330111G	Washer (ID6.2 x OD14 x 0.5t).....	2
9	099968002009	Micro Switch.....	1	29	099968002029	Motor and Pinion Assembly	1
10	099968002010	Wire Terminal Assembly	1	30	099968002030	Screw (M4 x 10 mm).....	2
11	099968002012	Logo Label.....	2	31	099968002031	Spring Washer (M4).....	4
12	099968002013	Battery Connector Assembly	1	32	099968002032	Flat Washer (M4).....	4
13	099968002014	Screw (M2.9 x 12 mm).....	2	33	099968002033	Auxiliary Handle.....	1
14	31112650G	Guard.....	1	34	099968002034	Lower Auxiliary Handle Cover Assembly.....	1
15	941657002	Warning Label.....	1	35	099968002035	Screw (M4 x 50 mm).....	2
16	32901639G	Hex Nut (M5)	2	36	33901650G	Spacer	2
17	099968002018	Gear Box Assembly.....	1	37	099968002037	Upper Auxiliary Handle Cover	1
18	940705002	Lithium Label (Right).....	1	38	940705003	Lithium Label (Left)	1
19	099968002020	Blade Shield	1	Not Shown:			
20	31113650G	Blade, Cam, and Clutch Assembly.....	1	988000817	Operator's Manual		
21	34110454-1G	Debris Remover.....	1	3-16-12			
22	33311454G	Spacer	2	(REV:01)			

WARNING: Improper repair of a double insulated tool can result in damage to the double insulation system possibly causing electrical shock or electrocution. Any repairs requiring disassembly of your tool requires safety testing and should only be performed by a Ryobi Authorized Service Center. For the service center nearest you call 1-800-860-4050.