

# EXPLODED VIEW AND PARTS LIST

## VUE ÉCLATÉE ET LISTE DES PIÈCES

### VISTA DESARROLLADA Y LISTA DE PIEZAS

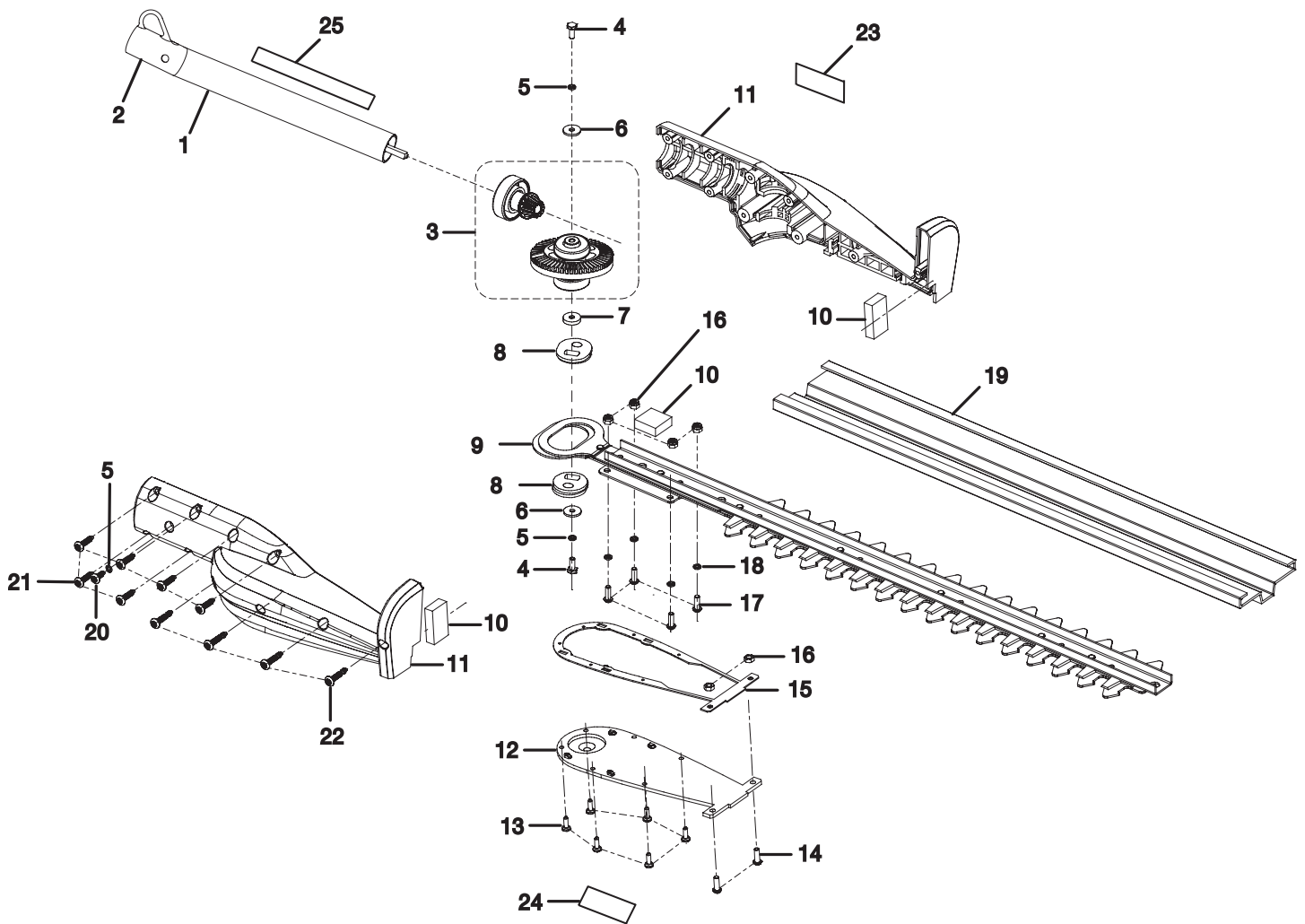

# EXPLODED VIEW AND PARTS LIST

## VUE ÉCLATÉE ET LISTE DES PIÈCES

### VISTA DESARROLLADA Y LISTA DE PIEZAS

KEY NO. Pièce Num. Núm. Ref.	PART NO. Num. Réf. Núm. Pieza	DESCRIPTION	DESCRIPTION	DESCRIPCIÓN	QTY. Qté. Cant.
1	308893002	Lower Drive Shaft Assembly (Inc. Key No. 26)	Arbre moteur inférieur (incl. pièce réf. 26)	Conjunto del eje de impulsión inferior (incl. pza. núm. ref. 26)	1
2	518019002	Hanger Cap	Capuchon de suspension	Tapa de suspensión	1
3	308894002	Output Gear and Pinion Assembly	Engrenages de sortie et pignon	Conjunto del piñón y del engranaje de salida	1
4	660927001	* Screw (M5 x 10 mm)	Vis (M5 x 11.5 mm)	Tornillo (M5 x 11.5 mm)	2
5	678343001	* Spring Washer (M5)	Rondelle élastique	Arandela elástica	2
6	678341002	* Washer (M5)	Rondelle	Arandela	2
7	638342001	Cam Spacer	Entretoise de came	Espaciador de le va	1
8	678350001	Cam	Came	Leva	2
9	308548001	Blade Assembly	Ensemble de lame	Conjunto de las hojas	1
10	901382001	Felt	Feutre	Filtro	3
11	120530011	Housing Assembly	Ensemble de boîtier	Conjunto de la armazón	1
12	518464002	Housing Bottom Plate	Plaque inférieure du boîtier	Placa inferior de la armazón	1
13	660923001	* Screw (M3 x 8 mm)	Vis (M3.5 x 8 mm)	Tornillo (M3.5 x 8 mm)	6
14	660924001	* Screw (M4 x 12 mm)	Vis (M4 x 11.5 mm)	Tornillo (M4 x 11.5 mm)	2
15	591617001	Seal	Joint	Sello	1
16	678344002	* Nut (M4)	Écrou (M4)	Tuerca (M4)	6
17	660924002	* Screw (M4 x 16 mm)	Vis (M4 x 15.5 mm)	Tornillo (M4 x 15.5 mm)	4
18	678346001	* Spring Washer (M4)	Rondelle élastique	Arandela elástica	4
19	518463001	Scabbard	Fourreau	Funda	1
20	660925002	* Screw (M4 x 9 mm)	Vis (M4 x 9 mm)	Tornillo (M4 x 9 mm)	1
21	660927002	* Screw (M5 x 14.5 mm)	Vis (M5 x 14.5 mm)	Tornillo (M5 x 14.5 mm)	6
22	660926001	* Screw (M5 x 26.5 mm)	Vis (M5 x 26.5 mm)	Tornillo (M5 x 26.5 mm)	4
23	940705023	Logo Label	Autocollant de logo	Etiqueta logotipo	1
24	940680005	Hot Surface Label	Étiquette de surface brûlante	Etiqueta superficial caliente	1
25	940657028	Warning Label	Étiquette d'avertissement	Etiqueta de advertencia	1
	987000383	Operator's Manual	Manuel d'utilisation	Manual del operador	1

\* STANDARD HARDWARE ITEM — MAY BE PURCHASED LOCALLY

\* ARTICLE DE QUINCAILLERIE STANDARD — EN VENTE DANS LES MAGASINS LOCAUX

\* ARTÍCULO ESTÁNDAR DE FERRETERÍA — PUEDE ADQUIRIRSE EN LA LOCALIDAD