

RYOBI SANDER – MODEL NUMBER RS2418

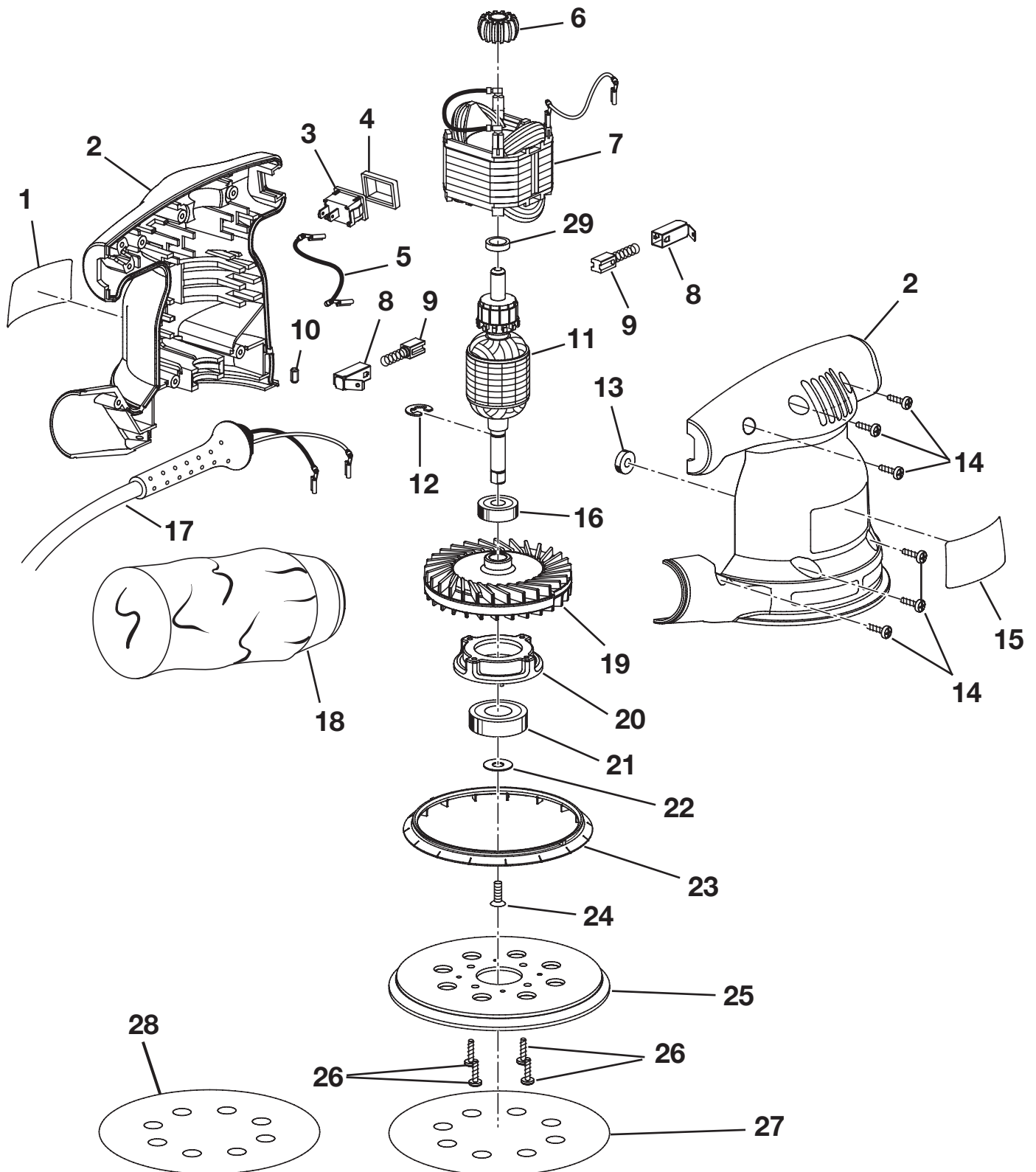

WARNING:

Improper repair of a double insulated tool can result in damages to the double insulation system possibly causing electrical shock or electrocution. Any repairs requiring disassembly of your tool requires safety testing and should only be performed by a Ryobi Authorized Service Center. For the repair center nearest you call 1-800-525-2579.

RYOBI SANDER – MODEL NUMBER RS2418

The model number will be found on a plate attached to the motor housing. Always mention the model number in all correspondence regarding your **SANDER** or when ordering repair parts.

PARTS LIST

KEY NO.	PART NO.	DESCRIPTION	QTY.
1	982754-001	LOGO PLATE.....	1
2	970121-005	HOUSING ASSEMBLY	1
3	968303-035	SWITCH ASSEMBLY (INCLUDES KEY NO. 4)	1
4	971443-001	SWITCH COVER.....	1
5	975421-001	BLACK LEAD.....	1
6	998044-001	HEAT SINK W/BEARING	1
7	976802-001	FIELD ASSEMBLY	1
8	999185-001	BRUSH TUBE.....	2
9	968304-059	BRUSH ASSEMBLY.....	2
10	623019-004	RUBBER PLUG	1
11	968306-139	ARMATURE ASEMBLY (INCLUDES KEY NOS. 12 AND 16).....	1
12	623111-004	RETAINING RING EXTERNAL	1
13	623552-004	STATOR PAD	1
14	990908-009	SCREW (#6-19 X 5/8 in. PAN HD. HI-LO).....	6
15	982753-002	DATA PLATE.....	1
16	968305-003	BALL BEARING (NACHI 608ZZ C3/1E).....	1
17	970777-019	CORD	1
18	975244-003	DUST BAG ASSEMBLY	1
19	975237-001	FAN.....	1
20	976801-001	BEARING CAP W/BEARING (INCLUDES KEY NO. 21).....	1
21	969235-004	BALL BEARING (NACHI 6002 2NSE C3/1E).....	1
22	931744-828	WASHER.....	1
23	975239-001	BRAKE.....	1
24	622183-026	SCREW (#8-32 X 1/2 in. FLAT HD.).....	1
25	975773-001	BACKING PAD W/BRAKE (INCLUDES KEY NO. 23)	1
26	990908-008	SCREW (#6-19 X 9/16 in. PAN HD.)	4
27	***	SANDING DISC	1
28	974484-001	CONVERSION PAD	1
29	5911701	PHENOLIC WASHER.....	1
	972000-994	OPERATOR'S MANUAL	
	10-25-05	REPAIR SHEET (REV:00)	

*** COMPLETE ASSORTMENT AVAILABLE AT YOUR NEAREST CATALOG ORDER OR RETAIL STORE