

RYOBI RECIPROCATING SAW – MODEL NUMBER RJ162VK

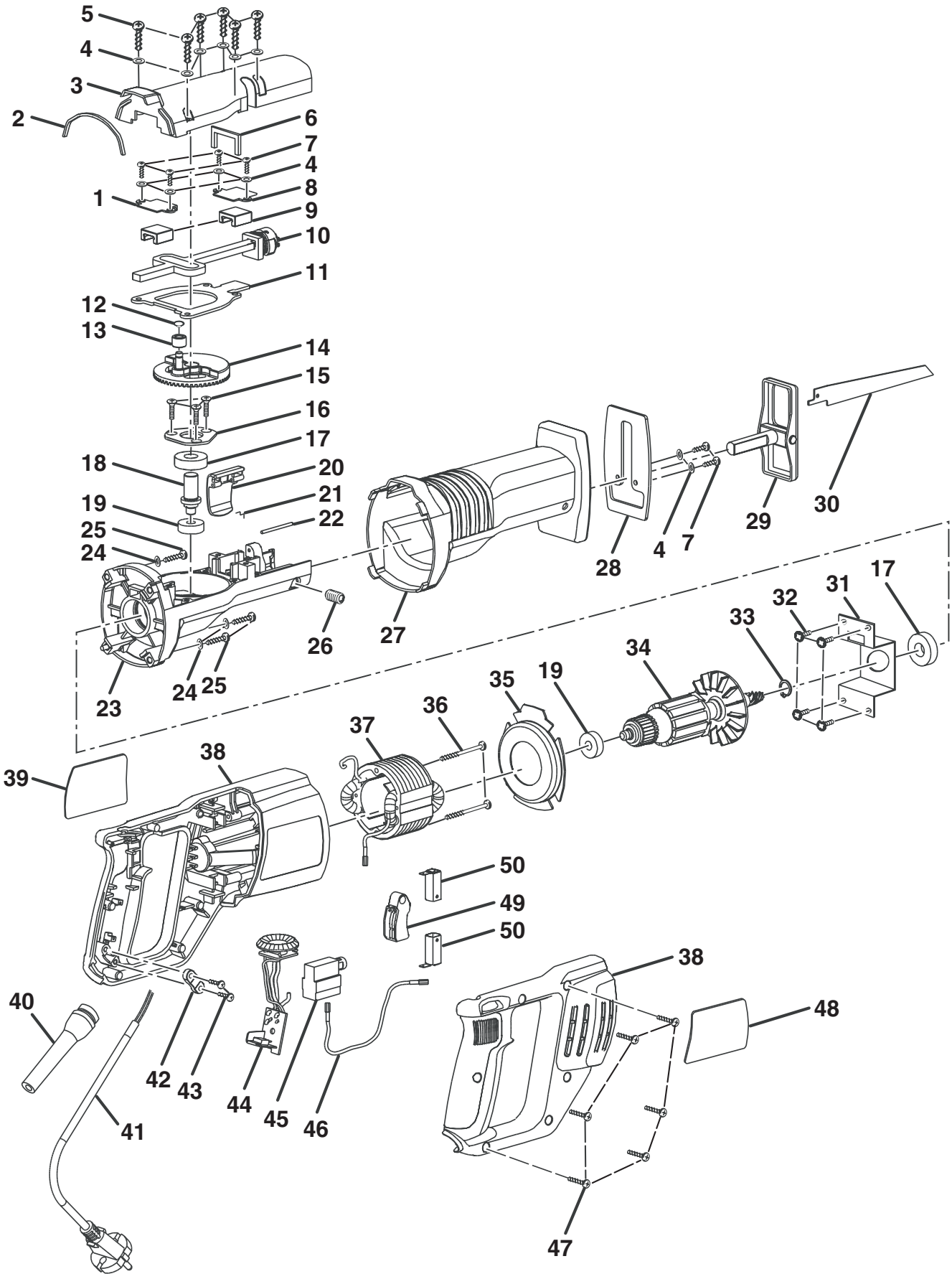

RYOBI RECIPROCATING SAW – MODEL NUMBER RJ162VK

The model number will be found on a plate attached to the motor housing. Always mention the model number in all correspondence regarding your **RECIPROCATING SAW** or when ordering repair parts.

PARTS LIST

KEY PART NO. NUMBER	DESCRIPTION	QTY.	KEY PART NO. NUMBER	DESCRIPTION	QTY.
1 6934201	COVER PLATE.....	1	29 3021607	SHOE ASSEMBLY	1
2 9066701	GEAR CASE SEAL	1	30 6934701	SAW BLADE (6 in.)	1
3 5909501	GEAR CASE COVER.....	1	6934801	SAW BLADE (4 in.)	1
4 6703001	SPRING WASHER	12	31 6950301	BEARING RETAINER	1
5 6616503	* SCREW (M4 X 18 mm)	6	32 6622801	* SCREW (M3 X 8 mm FLAT HD.)	4
6 5682601	SEAL	1	33 6939601	RETAINING RING	1
7 6621202	* SCREW (M4 X 10 mm)	6	34 7436901	ARMATURE	1
8 6934901	COVER PLATE	1	35 5909001	BAFFLE	1
9 6935601	GUIDE BLOCK	2	36 6615601	SCREW (SELF TAPPING)	2
10 3000330	SAW BAR ASSEMBLY	1	37 7437001	FIELD	1
11 6934501	YOKE PLATE.....	1	38 200202330	HOUSING ASSEMBLY.....	1
12 6770401	RETAINING RING	1	39 940999013	LOGO PLATE	1
13 6829601	ROLLER BEARING.....	1	40 5629001	BEND RELIEF.....	1
14 3036203	GEAR ASSEMBLY	1	41 7320112	POWER CORD.....	1
15 6621301	* SCREW (M4 X 16 mm)	3	42 5950101	CORD CLAMP	1
16 6839502	SHAFT MOUNTING PLATE	1	43 6620805	* SCREW (M4 X 16 mm)	2
17 6939501	BALL BEARING (6001ZZ)	2	44 280013065	SPEED CONTROL BOARD	1
18 6940401	GEAR SHAFT	1	45 7615501	SWITCH (DEFOND)	1
19 6814104	BALL BEARING (608Z).....	2	7628601	SWITCH (BAICHENG).....	1
20 4009401	BLADE RELEASE LEVER.....	1	46 2913301	LEAD ASSEMBLY	1
21 6950201	SPRING	1	47 6620802	SCREW (SELF TAPPING)	6
22 6951801	PIN	1	48 940999014	DATA PLATE	1
23 6453501	GEAR CASE	1	49 5909201	TRIGGER	1
24 6886301	LOCK WASHER.....	4	50 290069077	BRUSH TUBE ASSEMBLY	2
25 6625902	SCREW (SELF TAPPING)	4	51 300636030	CARRYING CASE (NOT SHOWN)	1
26 6616926	* SCREW (M6 X 14 mm WASHER HD.) ..	1	983000628	OPERATOR'S MANUAL (960972001)	
27 5909101	RUBBER BOOT	1	983000628R	REPAIR SHEET (REV:01)	
28 6942301	GUARD PLATE	1	04-14-05		

WARNING: Improper repair of a double insulated tool can result in damage to the double insulation system possibly causing electrical shock or electrocution. Any repairs requiring disassembly of your tool requires safety testing and should only be performed by a Ryobi Authorized Service Center. For the service center nearest you call 1-800-525-2579.

* Standard Hardware Item – May Be Purchased Locally