

RIDGID
Tile Saw
Model No. R40211/R40211CN
Repair Sheet

RIDGID
Scie à carreaux
Numéro de modèle R40211/R40211CN
Feuille de réparation

RIDGID
Sierra de losas
Número de modelo R40211/R40211CN
Listas de piezas de repuesto

ONE WORLD TECHNOLOGIES, INC.
P.O. Box 1427
Anderson, SC 29622, USA
1-866-539-1710 ■ powertools.RIDGID.com

FIGURE A / FIGURA A

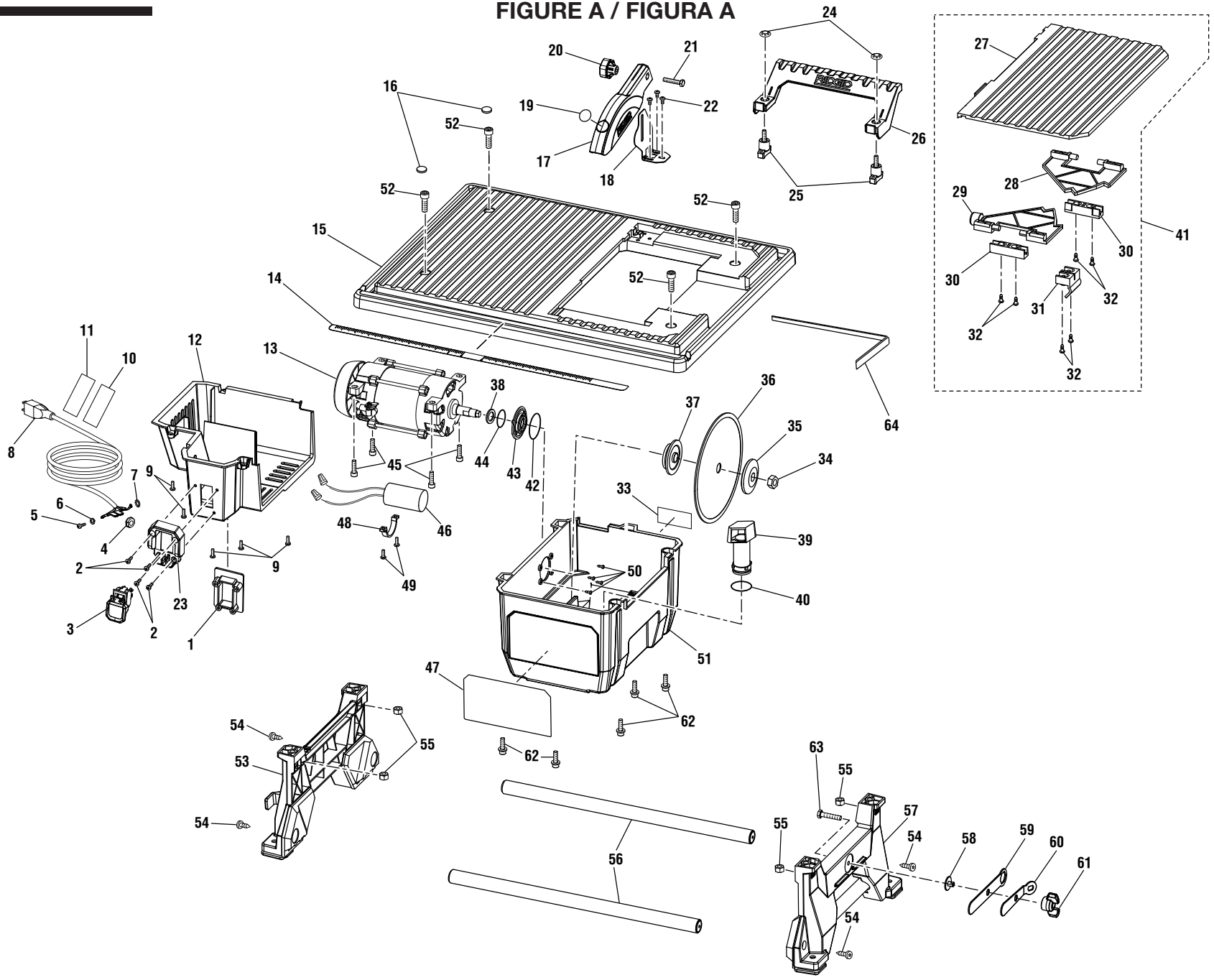



R40211/R40211CN

FIGURE A

KEY P/N	DESCRIPTION	QTY	KEY P/N	DESCRIPTION	QTY	KEY P/N	DESCRIPTION	QTY			
1	089041047029	Rear Switch Cover.....	1	23	089041047030	Front Switch Cover.....	1	45	089041047033	Screw (M6 x 25 mm).....	4
2	089240031024	Screw (M4 x 15 mm).....	4	24	089041033063	Push Nut (M5).....	2	46	080009022043	Capacitor	1
3	080009022108	On/Off Switch	1	25	089041047010	Rear Table Knob	2	47	089041047902	Warning/Logo Label	1
4	089041047023	Strain Relief	1	26	089041047702	Rear Table Support (Inc. Key Nos. 24-25).....	1	48	089041047035	Capacitor Strap	1
5	080009019032	Screw (M4 x 8 mm).....	1	27	089041047044	Bevel Table	1	49	080009007031	Screw (M4 x 8 mm).....	2
6	089041047025	Spring Washer (M4)	1	28	089041047045	Bevel Plate Support (Right)	1	50	089041047017	Screw (M3 x 8 mm).....	4
7	080015001496	Washer (M4).....	1	29	089041047049	Bevel Plate Support (Left).....	1	51	089041047704	Cabinet (Inc. Key No. 33 and 47)	1
8	080009022107	Power Cord Assembly	1	30	089041047046	Support Arm Base	2	52	089041047117	Screw (M8 x 25 mm, Hex Soc. Hd.)	4
9	089041047028	Screw (M4 x 12 mm).....	5	31	089041047048	Locking Block.....	1	53	089041047051	Left Table Leg	1
10	089041047906	Warning Cordwrap Label (FR/SP).....	1	32	089041047047	Screw (M5 x 12 mm).....	6	54	089041047050	Screw (M5 x 13 mm).....	4
11	089041047907	Danger Cordwrap Label	1	33	089041047901	Data Label (R40211)	1	55	089041047064	Hex Nut (M8).....	4
12	089041047022	Motor Housing	1		089041057901	Data Label (R40211CN).....	1	56	089041047055	Tube w/Plug.....	2
13	N/A	Motor Assembly (Inc. Key Nos. 38, 44 and 46)	1	34	080009019035	Arbor Nut	1	57	089041047058	Right Table Leg.....	1
14	089041047904	Scale Label	1	35	080009019034	Outer Wheel Washer.....	1	58	089041047059	Wrench Storage Bracket	1
15	089041047703	Table Assembly (Inc. Key Nos. 14 and 64)	1	36	089009035905	Cutting Wheel	1	59	089041047060	Wheel Wrench	1
16	089041047116	Screw Cover (Plug).....	2	37	080009019033	Inner Wheel Washer.....	1	60	089041047061	Arbor Wrench.....	1
17	089041047701	Splash Hood Assembly (Inc. Key Nos. 18-22).....	1	38	089041047021	Seal.....	1	61	089041047062	Wing Nut (Wrench Knob)	1
18	089041047004	Splash Hood Bracket (Riving Knife)	1	39	089041047043	Overflow Drain w/O-Ring (Inc. Key No. 40)	1	62	089041047037	Screw (M6 x 16 mm).....	5
19	089041047903	No Hands Warning Label.....	1	40	080009019011	O-Ring	1	63	080009019057	Screw (M6 x 30 mm, Hex. Hd.).....	1
20	089041047115	Knob (M6)	1	41	089041047706	Bevel Table Assembly (Inc. Key Nos. 27-32).....	1	64	089041047015	Sponge	1
21	089041047002	Screw (M6 x 26 mm, Hex Hd.).....	1	42	089041047019	O-Ring	1		Not Shown:		
22	089041047001	Screw (M4 x 6 mm, Pan Hd.).....	3	43	089041047020	Arbor Seal Assembly	1		995000122	Operator's Manual (089041047908)	
				44	089041047070	O-Ring	1		6-22-20		
									(Rev:02)		

FIGURE B / FIGURA B

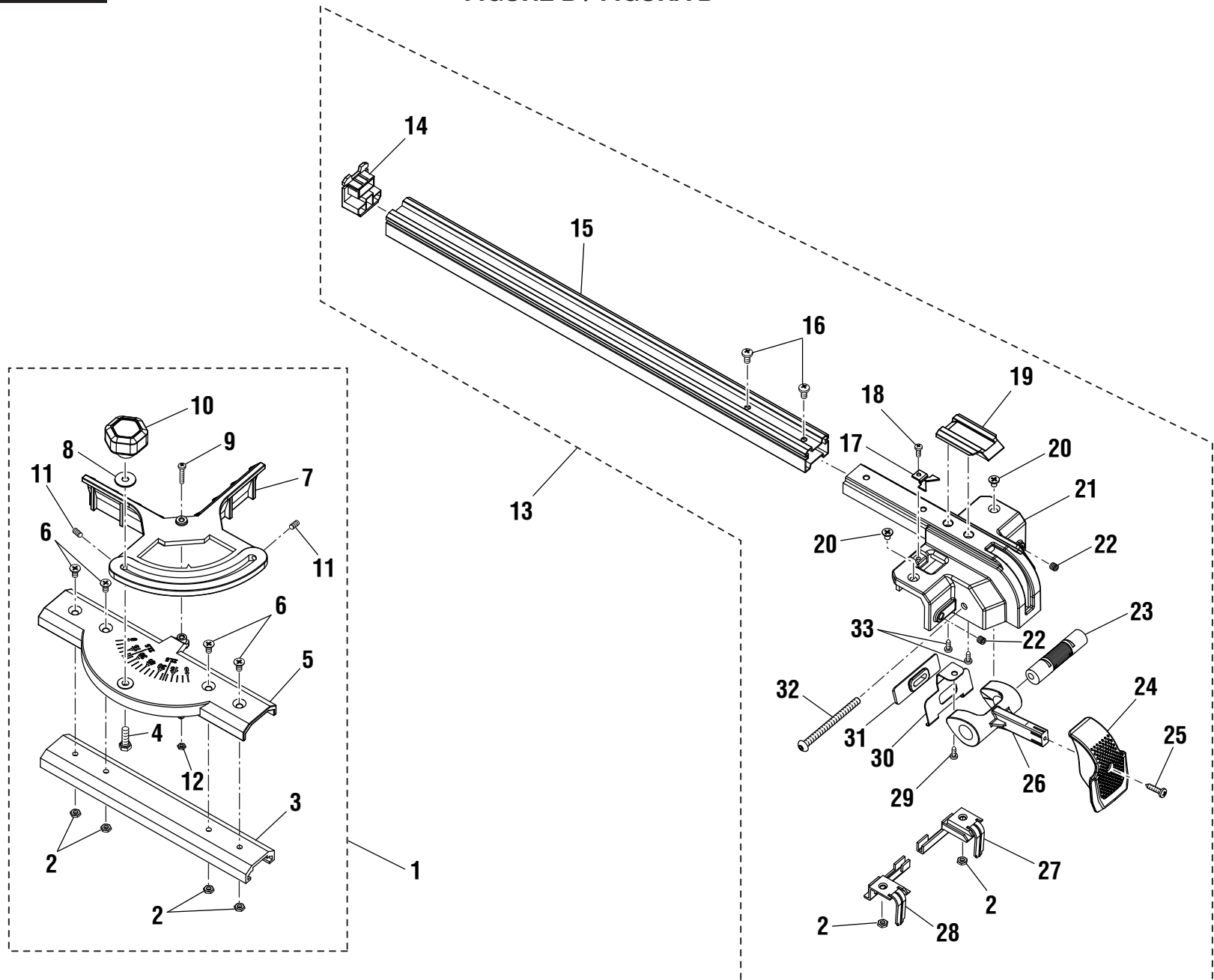



R40211/R40211CN

FIGURE B / FIGURA B

KEY P/N	DESCRIPTION	QTY	CLÉ NUM.	DESCRIPTION	QTÉ. LLAVE NÚM.	DESCRIPCIÓN	CANT.	
1 089041047710	Miter Gauge Assembly (Inc. Key Nos. 2-12).....	1	089041047710	Ensemble de guide d'onglet (incl. lég. réf. 2-12).....	1	089041047710	Conjunto de la guía de ingletes (incl. núm. ref. 2-12).....	1
2 080009022099	Hex Nut (M4).....	6	080009022099	Écrou (hexagonal M4).....	6	080009022099	Tuerca hexagonal (M4)	6
3 089041047118	Miter Gauge Support.....	1	089041047118	Support de guide d'onglet.....	1	089041047118	Soporte de la guía de ingletes.....	1
4 089041047088	Screw (M5 x 20 mm, Hex Hd.).....	1	089041047088	Vis (M5 x 20 mm, tête hex.).....	1	089041047088	Tornillo (M5 x 20 mm, cab. hex.)	1
5 089041047087	Miter Gauge Bracket	1	089041047087	Support d'onglet coulissant	1	089041047087	Soporte de ingletes deslizable	1
6 089041047086	Screw (M4 x 6 mm, Pan Hd.).....	4	089041047086	Vis (M4 x 8 mm, tête bombée).....	4	089041047086	Tornillo (M4 x 8 mm, cab. tronc.).....	4
7 089041047092	Miter Gauge.....	1	089041047092	Guide d'onglet.....	1	089041047092	Guía de ingletes.....	1
8 089041047084	Washer (M5).....	1	089041047084	Rondelle (M5).....	1	089041047084	Arandela (M5)	1
9 089041047091	Screw (M3 x 18 mm, Phillips Hd.)	1	089041047091	Vis (M3 x 20 mm, tête bombée).....	1	089041047091	Tornillo (M3 x 20 mm, cab. tronc.).....	1
10 089041047083	Knob	1	089041047083	Bouton	1	089041047083	Perilla.....	1
11 089041047085	Screw (M4 x 8 mm).....	2	089041047085	Vis (M4 x 8 mm).....	2	089041047085	Tornillo (M4 x 8 mm)	2
12 080009019074	Hex Lock Nut (M3).....	1	080009019074	Écrou de blocage six pans (M3)	1	080009019074	Tuerca hexagonal de seguridad (M3) ..	1
13 089041047709	Rip Fence Assembly (Inc. Key Nos. 14-33).....	1	089041047709	Ensemble de guide longitudinal (incl. lég. réf. 14-33).....	1	089041047709	Conjunto de la guía de corte al hilo (incl. núm. ref. 14-33).....	1
14 089041047114	Front Fence Cap.....	1	089041047114	Capuchon de guide avant	1	089041047114	Tapa de la guía frente	1
15 089041047113	Rip Fence	1	089041047113	Guide longitudinal.....	1	089041047113	Guía de corte al hilo.....	1
16 089006017041	Screw (M4 x 10 mm).....	2	089006017041	Vis (M4 x 10 mm)	2	089006017041	Tornillo (M4 x 10 mm)	2
17 089041047096	Fence Indicator.....	1	089041047096	Indicateur de guide.....	1	089041047096	Indicador de la guía	1
18 089041047095	Screw (M3 x 8 mm).....	1	089041047095	Vis (M3 x 8 mm).....	1	089041047095	Tornillo (M3 x 8 mm)	1
19 089041047097	Fence Cap	1	089041047097	Capuchon de guide	1	089041047097	Tapa de la guía trasero	1
20 089041047098	Screw (M4 x 4 mm).....	2	089041047098	Vis (M4 x 6 mm).....	2	089041047098	Tornillo (M4 x 6 mm)	2
21 089041047111	Fence Bracket	1	089041047111	Support de guide.....	1	089041047111	Soporte de guía	1
22 089041047101	Set Screw (M4 x 6 mm)	2	089041047101	Vis d'arrêt (M4 x 6 mm)	2	089041047101	Tornillo fijadore (M4 x 6 mm)	2
23 089041047102	Eccentric Shaft	1	089041047102	Arbre de excentrique.....	1	089041047102	Eje del cojinete excéntrica.....	1
24 089041047103	Fence Locking Lever	1	089041047103	Guide de levier.....	1	089041047103	Guía de la palanca.....	1
25 089041047104	Screw (M4 x 20 mm).....	1	089041047104	Vis (M4,2 x 16 mm).....	1	089041047104	Tornillo (M4,2 x 16 mm)	1
26 089041047105	Locking Wheel.....	1	089041047105	Meule de verrouillage	1	089041047105	Disco de seguridad.....	1
27 089041047112	Left Clamp.....	1	089041047112	Bride gauche	1	089041047112	Prensa izquierdo.....	1
28 089041047099	Right Clamp.....	1	089041047099	Bride droit.....	1	089041047099	Prensa derecho	1
29 089041047107	Screw (M4 x 6 mm).....	1	089041047107	Vis (M4 x 6 mm).....	1	089041047107	Tornillo (M4 x 6 mm)	1
30 089041047108	Locking Piece.....	1	089041047108	Pièce frein.....	1	089041047108	Pieza de fijación.....	1
31 089041047109	Rubber Gasket	1	089041047109	Joint en caoutchouc.....	1	089041047109	Junta de goma.....	1
32 089041047106	Screw (M5 x 65 mm).....	1	089041047106	Vis (M4 x 65 mm).....	1	089041047106	Tornillo (M4 x 65 mm)	1
33 089041047110	Screw (M3 x 8 mm).....	2	089041047110	Vis (M3 x 8 mm).....	2	089041047110	Tornillo (M3 x 8 mm)	2

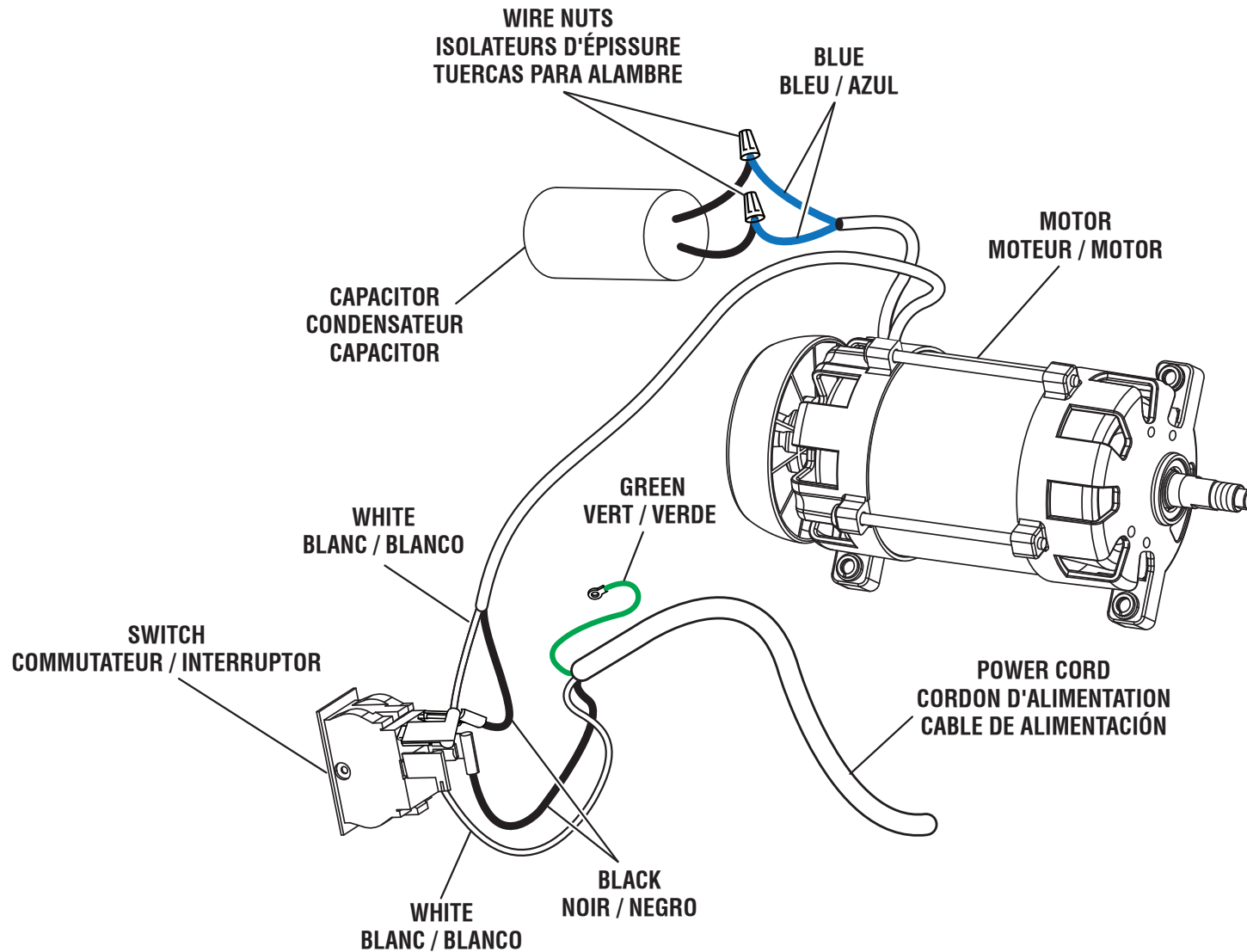

WIRING DIAGRAM / SCHÉMA DE CÂBLAGE / DIAGRAMA DE CABLEADO