

# RIDGID® R3101

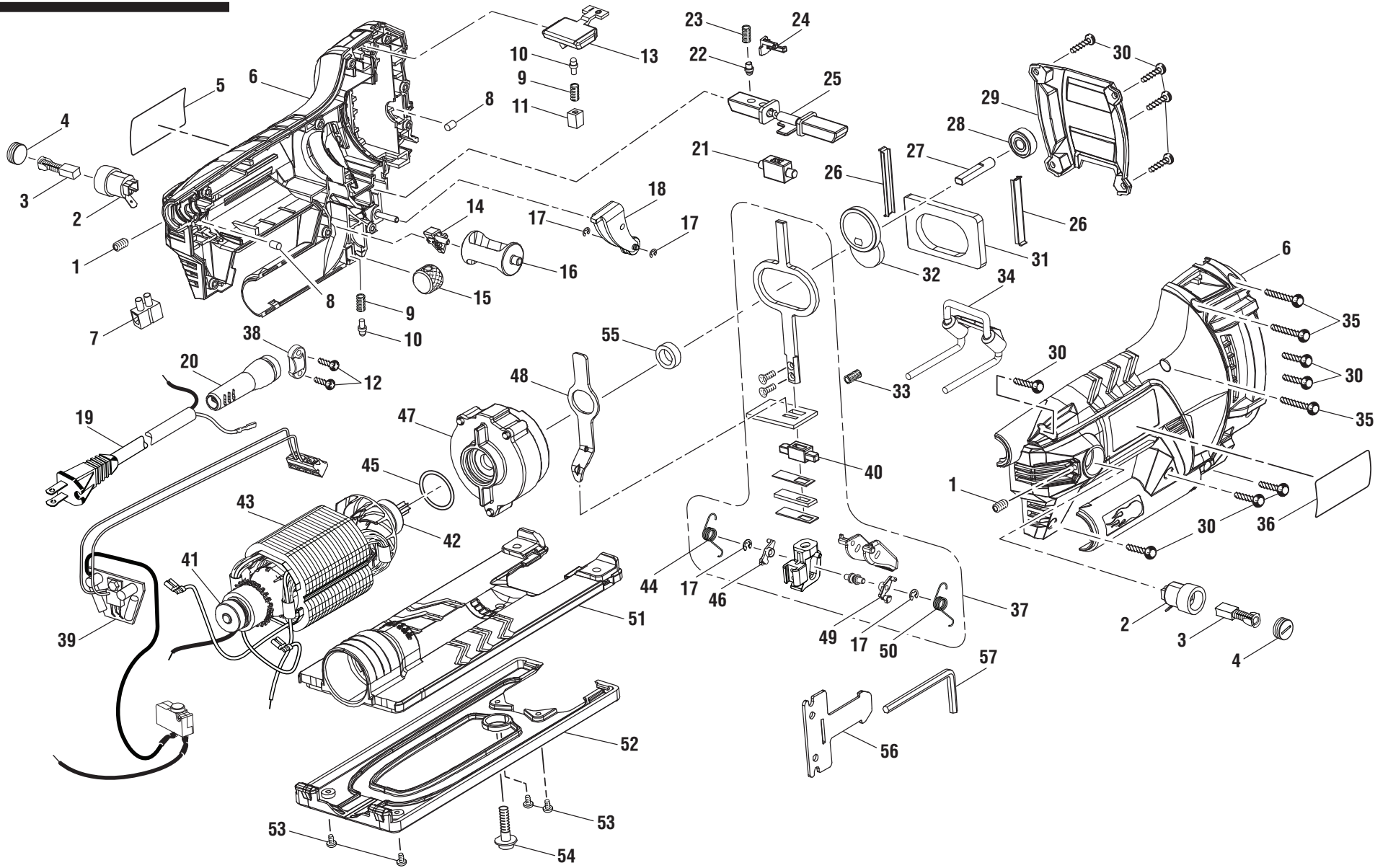

- ⚠ WARNING:** The assembly shown represents an important part of the Double Insulated System. To avoid the possibility of alteration or damage to the System, service should be performed by your nearest authorized service center.
- ⚠ AVERTISSEMENT:** L'ensemble illustré représente une partie importante du système à isolation double. Afin d'éviter la possibilité de modification ou de dommage au système, la réparation ne doit être effectuée que par votre centre de réparation centre commercial autorisé.
- ⚠ ADVERTENCIA:** El conjunto que se ilustra representa una parte importante del Sistema de Aislamiento Doble. Para evitar la posibilidad de alteración o daño del sistema, la reparación debe ser efectuada en su centro de servicio autorizado.

KEY P/N	DESCRIPTION	QTY	KEY P/N	DESCRIPTION	QTY	KEY P/N	DESCRIPTION	QTY
1	660439003 Set Screw (M4 x 4.5 mm).....	2	24	522114001 Retainer .....	1	46	690377003 Right Linkage Arm.....	1
2	516850001 Brush Holder .....	2	25	201636004 Orbital Control Assembly .....	1	47	304035001 Gear case Assembly .....	1
3	290848001 Brush Assembly .....	2	26	633379001 Slide Plate .....	2	48	633328001 Orbital Bar .....	1
4	516851001 Brush Cap .....	2	27	621141002 Output Shaft.....	1	49	690377008 Left Linkage Arm .....	1
5	940304530 Logo Label .....	1	28	681296001 Ball Bearing.....	1	50	691965001 Left Coil Spring.....	1
6	201754004 Housing Assembly.....	1	29	641646003 Front Cover.....	1	51	641668003 Base .....	1
7	690331004 Terminal Block.....	1	30	660031012 Screw (M3.5 x 14 mm) .....	10	52	521927001 Subbase .....	1
8	560075001 Bearing Plug .....	2	31	633327001 Counterbalance.....	1	53	660211006 Screw (M3 x 6 mm) .....	4
9	692670001 Compression Spring.....	2	32	201636007 Eccentric w/Bearing Assembly .....	1	54	661276001 Screw (M5 x 20 mm) .....	1
10	692667001 Pin .....	2	33	692671001 Spring.....	1	55	681426001 Bearing.....	1
11	521974001 Detent Bracket .....	1	34	201636005 Blade Guard Assembly.....	1	56	562574001 Hex Key Strap .....	1
12	660206050 Screw (M3.5 x 10 mm) .....	2	35	660230014 Screw (M3 x 20 mm) .....	3	57	681215001 Hex Key (M4).....	1
13	521970002 Switch Actuator.....	1	36	940488184 Data Label .....	1	<b>Not Shown:</b>		
14	521972001 Blower Tube Button.....	1	37	303974001 Saw Bar Assembly (Inc. Key Nos. 17, 40, 44, 46 and 49-50).....	1	690227040	T-Shank Metal Cutting Blade .....	1
15	692668001 Rotate Screw.....	1	38	512879002 Cord Clamp.....	1	690227041	T-Shank Wood Cutting Blade.....	1
16	521973001 Blower Tube.....	1	39	201754002 Circuit Board w/Switch Assembly.....	1	902513003	Tool Bag .....	1
17	671319001 E-Ring.....	4	40	611187001 Lower Bushing .....	1	201754003	Optional Edge Guide Assembly .....	1
18	304034002 Blade Guide Assembly .....	1	41	6972701 Ball Bearing (626Z).....	1	521976001	Optional Anti-Splintering Insert .....	1
19	730387039 Power Cord .....	1	42	681461001 Ball Bearing (608RSB).....	1	560199002	Terminal Sleeve .....	2
20	560106001 Bend Relief.....	1	43	201636002 Motor Assembly .....	1	988000283	Operator's Manual (961067545).....	1
21	611186001 Upper Bushing .....	1	44	691966001 Right Coil Spring .....	1	4-2-12 (Rev:05)		
22	692675001 Detent Pin.....	1	45	562390001 O-Ring.....	1			
23	692674001 Spring.....	1						