

CAUTION: Items 12 and 26 must be assembled in direction shown. Retaining tooth on driver, and longest side of piston, must face front of tool. Do not rotate these parts.

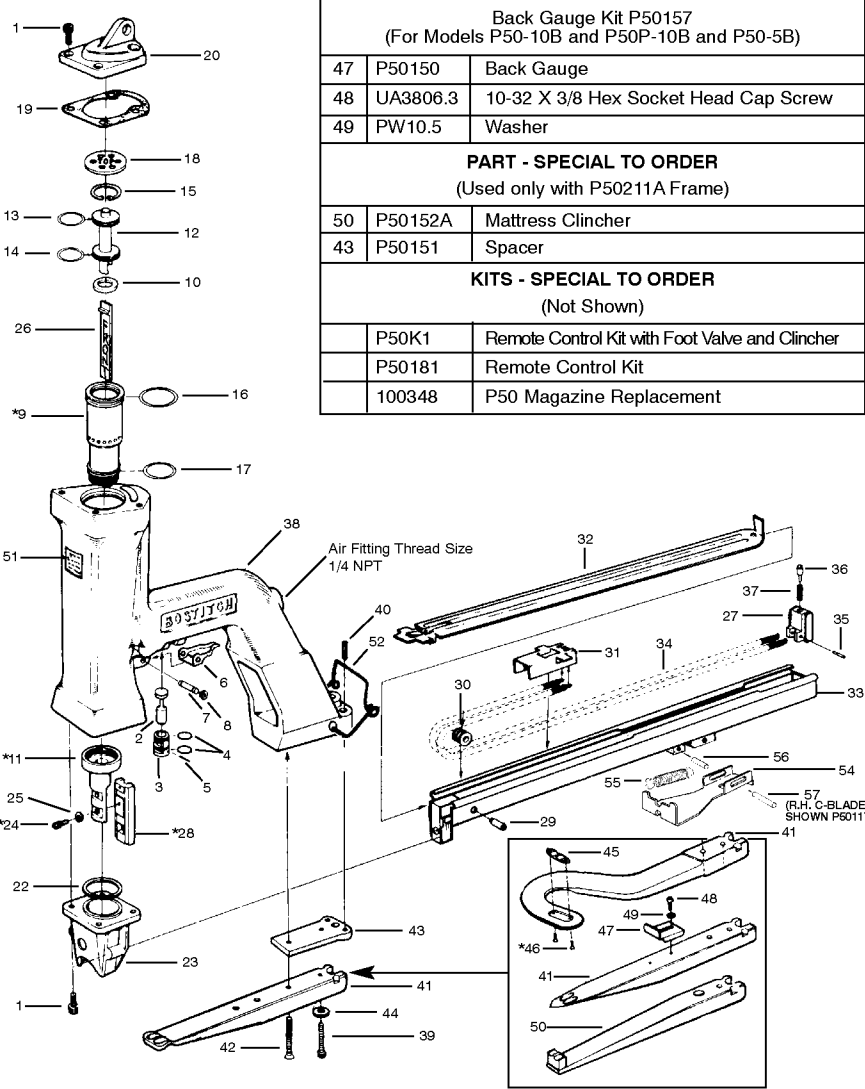
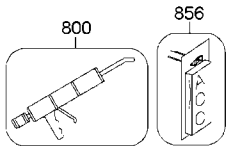

PARTS SPECIAL TO "C" BLADE MODELS		
45	P50137	Clincher
46	UA1804.7	4-40 X 1/4 Hex Socket Flat Head Screw
KITS - SPECIAL TO ORDER		
Back Gauge Kit P50157 (For Models P50-10B and P50P-10B and P50-5B)		
47	P50150	Back Gauge
48	UA3806.3	10-32 X 3/8 Hex Socket Head Cap Screw
49	PW10.5	Washer
PART - SPECIAL TO ORDER		
(Used only with P50211A Frame)		
50	P50152A	Mattress Clincher
43	P50151	Spacer
KITS - SPECIAL TO ORDER		
(Not Shown)		
	P50K1	Remote Control Kit with Foot Valve and Clincher
	P50181	Remote Control Kit
	100348	P50 Magazine Replacement

* IMPORTANT: SEE SPECIAL MAINTENANCE INSTRUCTIONS, PAGE 7
 * NOTE: FOR SB1030203/8 STAPLES USE P50191 SHUTTLE

Parts List for P50 Type 0

Item Number	Part Number	Description	Qty Required
1	UA3808.1	SCREW-10-32 X 1/2 SH	8
2	P50115A	TRIGGER VALVE STEM	1
3	P50114	TRIGGER VALVE BARREL	1
4	86458	O-RING	2
5	UB2112.2	SPRING PIN-.094X.75	1
6	P50119	TRIGGER	1
7	P50129	PIN-SPECIAL	1
8	85018	RING	1
9	P50196	SHUTTLE PISTON	1
10	P50108	DRIVER PISTON BUMPER	1
11	P50104	SHUTTLE PISTON SLEEV	1
12	P50118	DRIVER PISTON	1
13	87112	O-RING	1
14	87137	O-RING	1
15	87115	RING	1
16	87113	O-RING	1
17	850682	O-RING-1.112X.103	1
18	P50106	BUMPER	1
19	P50120	CYLINDER CAP GASKET	1
20	P50102	CYLINDER CAP	1
22	P50107	SHUTTLE PISTON BUMPE	1
23	P50105	NOSE GUIDE	1
24	UA3804.6	SCREW-SHCS-10-32X1/4	1
25	SW10E	WASHER-#10 EXT TOOTH	1
26	P50121	DRIVER	1
26	P50187	DRIVER	1
27	A05502101	BLOCK	1

Parts List for P50 Type 0

Item Number	Part Number	Description	Qty Required
28	103507	SHUTTLE-.050-3/8	1
28	P50186	SHUTTLE-.103	1
28	P50188	SHUTTLE-.050	1
28	P50191	SHUTTLE-.103-3/8	1
29	P50169	PIN-SPECIAL	1
30	P50168	ROLL	1
31	P50172	PUSHER	1
32	P50171A	ASSEMBLY-TOP GUIDE	1
33	P50213A	CORE CASE	1
33	P50213A	CORE CASE	1
33	P50213A	CORE CASE	1
33	104137	ASSY-CORE CASE	1
34	P50177	SPRING-EXTENSION	2
35	P50175	PIN-SPECIAL	1
36	P50173	PIN-SPECIAL	1
37	P50174	SPRING-COMPRESSION	1
38	P50212A	FRAME	1
38	P50211A	FRAME (MACHINING)	1
39	UA4824.2	SCREW-1/4-20 X 1 1/2	1
39	UA4812.1	SCREW-1/4-20 X 3/4 S	1
40	UA4808.4	SCREW-CONESSS-1/4-20	1
40	UA4816.12	SCREW-CONESSS-1/4-20	1
41	P50116A	BLUNT CLINCHER (SB)	1
41	P50117	BLADE	1
41	P50138	BLADE	1
42	UA5824.5	SCREW-SFHCS-5/16-18X	1
42	UA5816.7	SCREW-SFHCS-5/16-18X	1

Parts List for P50 Type 0

Item Number	Part Number	Description	Qty Required
43	P50151	SPACER	1
44	LW14	WASHER-1/4 LOCK ZINC	1
45	P50137	C BLADE CLINCHER	1
46	UA1804.7	SCREW-SFHCS/4-40X1/4	1
47	P50150	BACK GAUGE	1
48	000000-00	No Longer Available	1
49	PW10.5	PLAIN WASHER	1
50	P50152A	MATTRESS CLINCHER	1
51	159923	LABEL-WARNING-P50	1
52	P50197	MAGAZINE SPRING	1
53	P50210	LABEL- WARNING	1
54	A05502701	MAGAZINE CLAMP	1
55	P50218	SPRING-EXTENSION	1
56	UB2808.1	PIN- SPRING .101 X .	1
57	UB2112.2	SPRING PIN-.094X.75	1
800	100653	LUBE (2CC)	1
800	100679	LUBE (1LB.CAN)	1