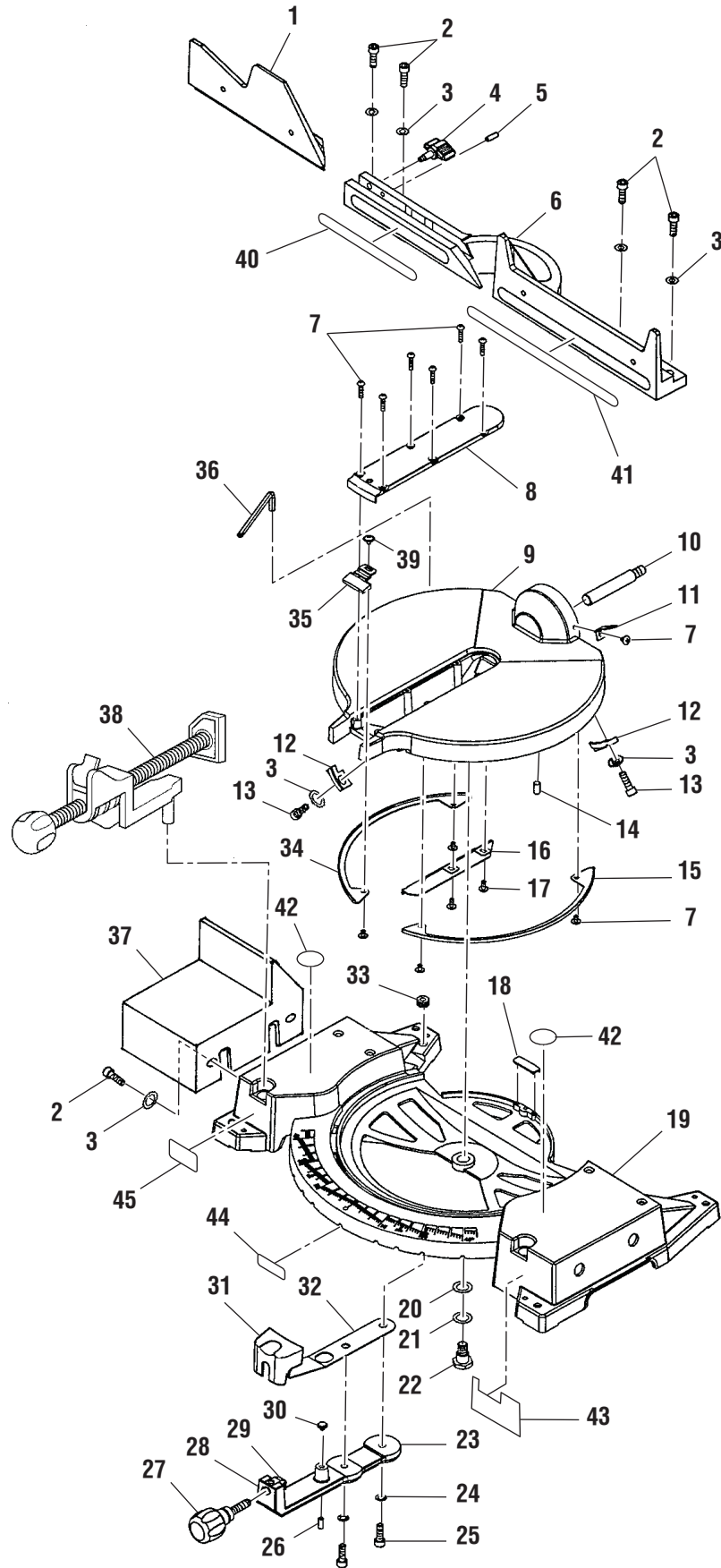

FIGURE A



RIDGID 12 in. COMPOUND MITER SAW – MODEL NUMBER MS1250LZ

The model number will be found on a plate attached to the motor housing. Always mention the model number in all correspondence regarding your **MITER SAW** or when ordering repair parts.

PARTS LIST FOR FIGURE A

Key No.	Part Number	Description	Qty.
1	828102	SLIDING FENCE.....	1
2	141594-17	SCREW (5/16-18 X 1 in. SOC CAP).....	1
3	821063-6	WASHER.....	8
4	827439	FENCE KNOB.....	1
5	820244-6	SCREW M6 X 1.0 X 18 mm PAN HD).....	1
6	828103	STATIONARY FENCE.....	1
7	816755-10	SCREW (M5 X 0.8-8 mm PAN CROSS).....	6
8	826886	THROAT PLATE.....	1
9	828104	TABLE.....	1
10	827434	BEVEL PIVOT SHAFT.....	1
11	827438	BEVEL INDICATOR.....	1
12	826882	BEVEL INDEX STOP.....	2
13	9421621	SCREW (5/16-18 X 5/8 in. SOC).....	2
14	827449	SCREW (M8 X 1.25-16 mm SOC SET LK).....	1
15	823331	SHOE (LEFT).....	1
16	827879	GUARD PLATE.....	1
17	827886	SCREW (M5-10 mm SEMS).....	1
18	823361	REAR BASE SHOE.....	1
19	828105	BASE.....	1
20	828116	SPRING WASHER.....	1
21	60047	WASHER.....	1
22	823355	TABLE PIVOT BOLT.....	1
23	828106	MITER ARM.....	1
24	140785-6	TOOTH LOCKWASHER (5/16 in.).....	2
25	9421622	SCREW (5/16-18 X 3/4 in. SOC CAP).....	2
26	828040-1	SCREW (M6 X 1.0-16 mm SET LOCK).....	2
27	828032	MITER KNOB.....	1
28	828031	MITER PLATE CLAMP.....	1
29	827886-1	SCREW (SEMS PAN LOCK WASHER).....	1
30	823356	FRONT BASE SHOE.....	1
31	828128	MITER INDEX GRIP.....	1
32	828029	MITER INDEX SPRING.....	1
33	823335	GROMMET.....	1
34	823332	SHOE (RIGHT).....	1
35	826885	MITER INDICATOR.....	1
36	823492	HEX WRENCH (L25).....	1
37	828109	EXTENSION TABLE.....	1
38	828048	CLAMP.....	1
39	828119-1	SCREW (M5-12 mm SEMS).....	1
40	867216001	FENCE LABEL (LEFT).....	1
41	867216002	FENCE LABEL (RIGHT).....	1
42	867227001	NO HANDS WARNING LABEL.....	2
43	867216029	CROWN MOLDING LABEL (RIGHT).....	1
44	871045004	DATA PLATE LABEL.....	1
45	867216031	CROWN MOLDING LABEL (LEFT).....	1
46	828050	HARDWARE BAG (NOT SHOWN)	

* Standard Hardware Item – May Be Purchased Locally

FIGURE B

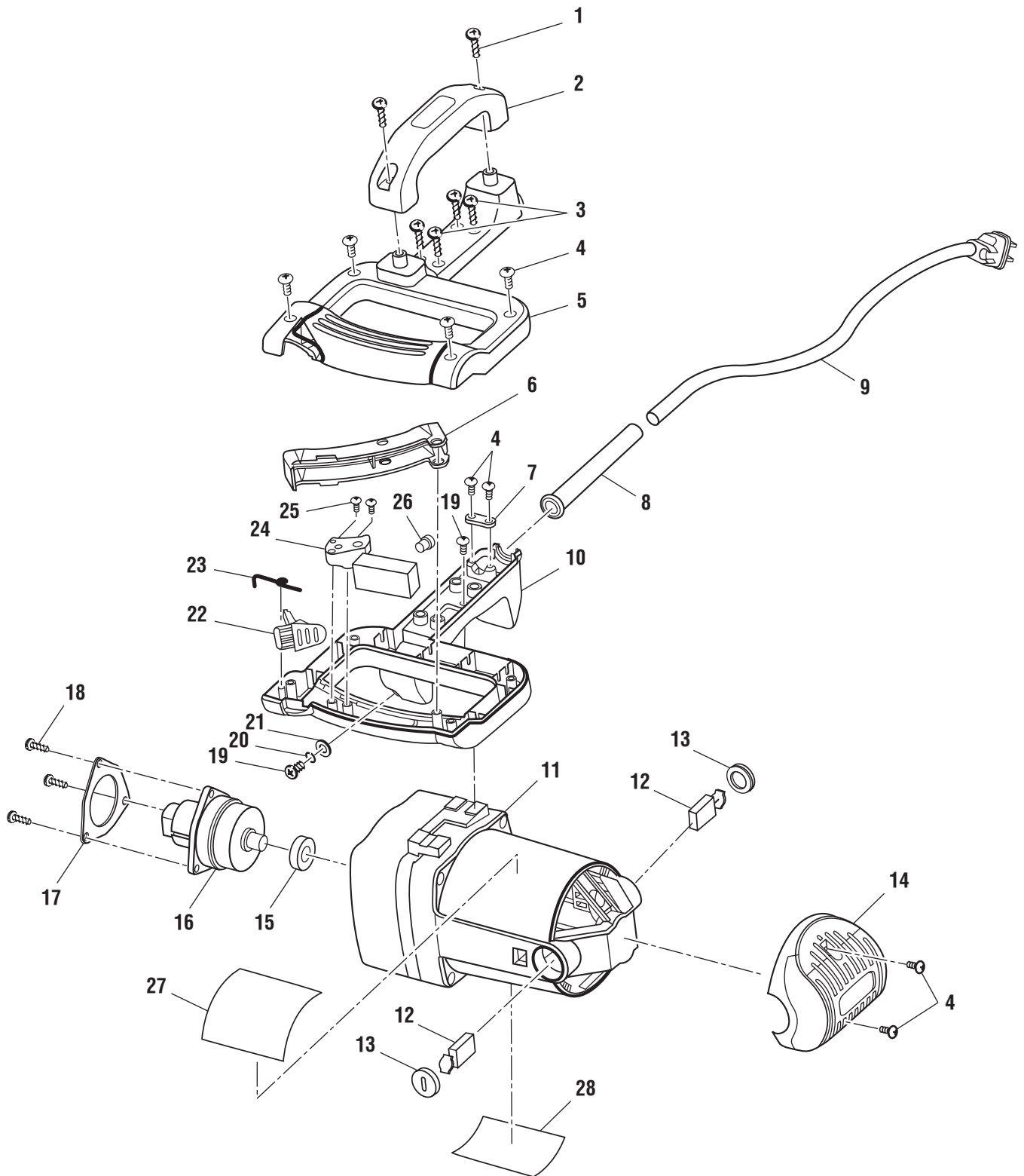

RIDGID 12 in. COMPOUND MITER SAW – MODEL NUMBER MS1250LZ

The model number will be found on a plate attached to the motor housing. Always mention the model number in all correspondence regarding your **MITER SAW** or when ordering repair parts.

PARTS LIST FOR FIGURE B

Key No.	Part Number	Description	Qty.
1	828123	SCREW (M5 X 30 mm PAN HD)	2
2	828063	HANDLE	1
3	820376-5	SCREW (M4 X 0.7-22 mm PAN HD).....	4
4	828122	SCREW (M4 X 14 mm PAN HD)	4
5	828062	HANDLE (INCLUDES UPPER AND LOWER HANDLE)	1
6	828059	SWITCH ACTUATOR.....	1
7	816725	CORD CLAMP.....	1
8	821122-1	STRAIN RELIEF	1
9	828057	POWER CORD	1
10	828056	LOWER HANDLE.....	1
11	828125	MOTOR.....	1
12	816768	BRUSH	2
13	816770	BRUSH COVER.....	2
14	828064	REAR MOTOR COVER.....	1
15	816781	NEEDLE BEARING	1
16	828133-2	ARBOR ASSEMBLY.....	1
17	823271	BEARING RETAINER PLATE	1
18	816755-2	SCREW (M5 X 15 mm PAN HD)	3
19	820376-4	SCREW (M4 X 0.7-10 mm PAN HD).....	1
20	813303-4	LOCK WASHER (M4).....	1
21	821102	WASHER	1
22	828060	LOCK BUTTON	1
23	828061	TORSION SPRING	1
24	823493	SWITCH.....	1
25	828122-1	SCREW (M4 X 10 mm PAN HD)	2
26	803709-1	WIRE CONNECTOR (#12-#18).....	2
27	867216028	WARNING LABEL (ENGLISH/SPANISH)	1
28	867216030	WARNING LABEL (FRENCH)	1

* Standard Hardware Item – May Be Purchased Locally

FIGURE C

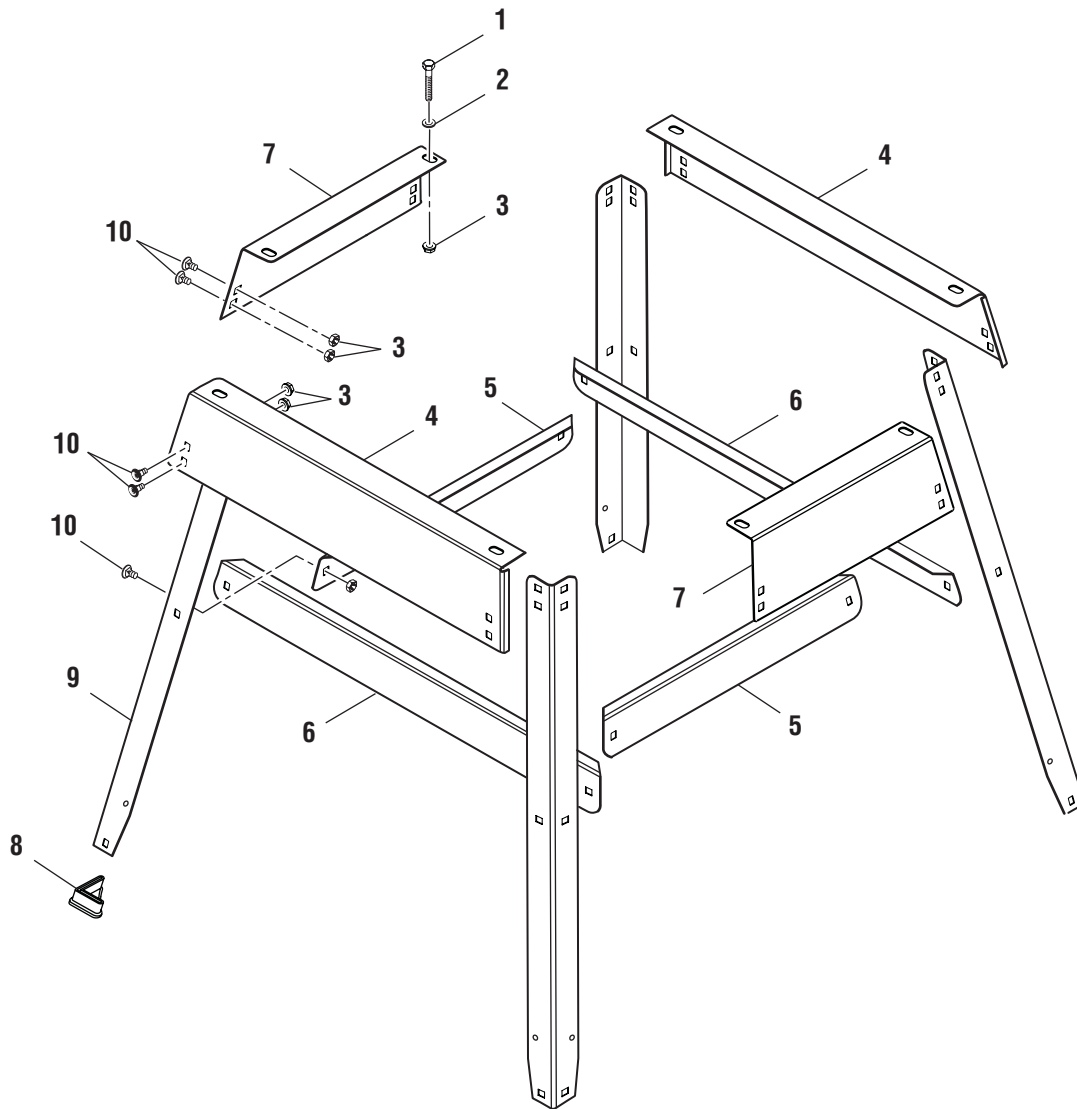

RIDGID 12 in. COMPOUND MITER SAW – MODEL NUMBER MS1250LZ

The model number will be found on a plate attached to the motor housing. Always mention the model number in all correspondence regarding your **MITER SAW** or when ordering repair parts.

PARTS LIST FOR FIGURE C

Key No.	Part Number	Description	Qty.
1	805467-13	SCREW (5/16-18 X 2-1/2 in. HEX HD).....	4
2	819198	WASHER.....	4
3	827566	HEX NUT (5/16-18 FLANGED).....	28
4	829621	BRACE (UPPER LONG).....	2
5	829623	BRACE (LOWER SHORT).....	2
6	829622	BRACE (LOWER LONG).....	2
7	829620	BRACE (UPPER SHORT).....	2
8	829619	FOOT	4
9	829624	LEG.....	4
10	825780-1	CARRIAGE BOLT (5/16-18 X 5/8 in.)	24
	829625	LEG SET HARDWARE BAG (NOT SHOWN)	

* Standard Hardware Item – May Be Purchased Locally

FIGURE D

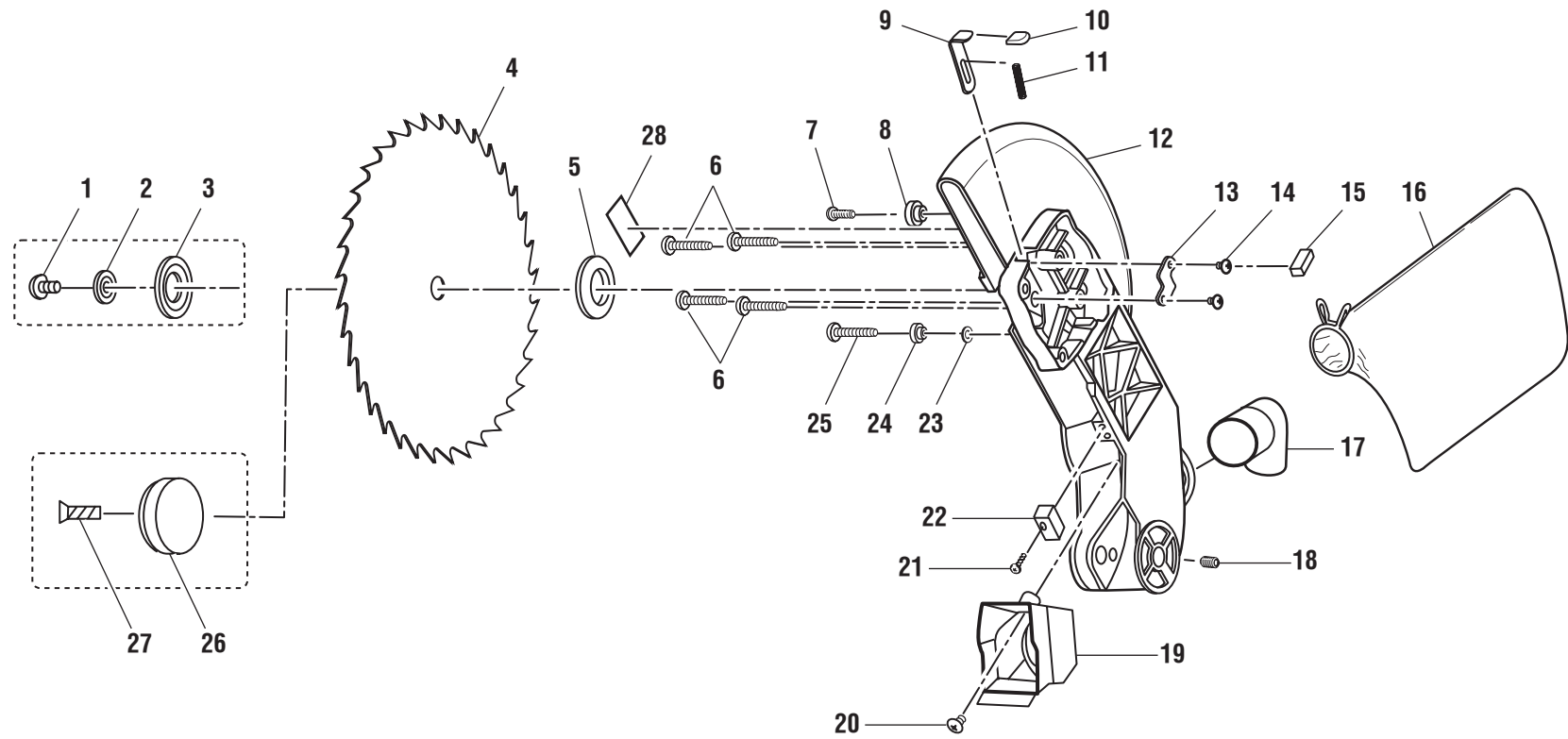

RIDGID 12 in. COMPOUND MITER SAW – MODEL NUMBER MS1250LZ

The model number will be found on a plate attached to the motor housing. Always mention the model number in all correspondence regarding your **MITER SAW** or when ordering repair parts.

PARTS LIST FOR FIGURE D

Key No.	Part Number	Description	Qty.
1	830525	BLADE SCREW (M10 x 20 mm)	1
2	830523	BLADE WASHER	1
3	089100300052	BLADE COLLAR (OUTER)	1
4	828042	BLADE	1
5	830526	BLADE COLLAR (INNER)	1
6	827886-2	SCREW (M8-35 SEMS PAN L/WSH).....	4
7	821878	SCREW (10-32 X 7/8 in. SHOULDER).....	1
8	827498	RUBBER SLEEVE	1
9	827512	ARBOR LOCK.....	1
10	827516	GRIP CAP	1
11	823402	SPRING	1
12	830531	UPPER ARM GUARD	1
13	823353	ARBOR LOCK PLATE	1
14	823404	SCREW (M5 X 0.8-8 mm)	2
15	823359	ARBOR LOCK GROMMET	1
16	828045	DUST BAG.....	1
17	828038	ELBOW	1
18	828040-1	SCREW (M6 X 1.0-16 mm SET LOCK).....	1
19	827543	SAWDUST CHUTE	1
20	828119	SCREW (M5 X 0.8-25 mm SEMS)	1
21	816755-6	SCREW (M5 X 0.8-16 mm PAN HD).....	1
22	823360	LOWER GUARD BUMPER	1
23	820238-2	WASHER.....	1
24	821862	BEARING GUIDE	1
25	821875-1	SCREW (M6 X 14 mm SHOULDER).....	1
26	830527	LASER	1
27	830522	LASER SCREW (M10 x 26 mm)	1
28	867216027	WARNING LABEL (UPPER GUARD)	1

FIGURE E

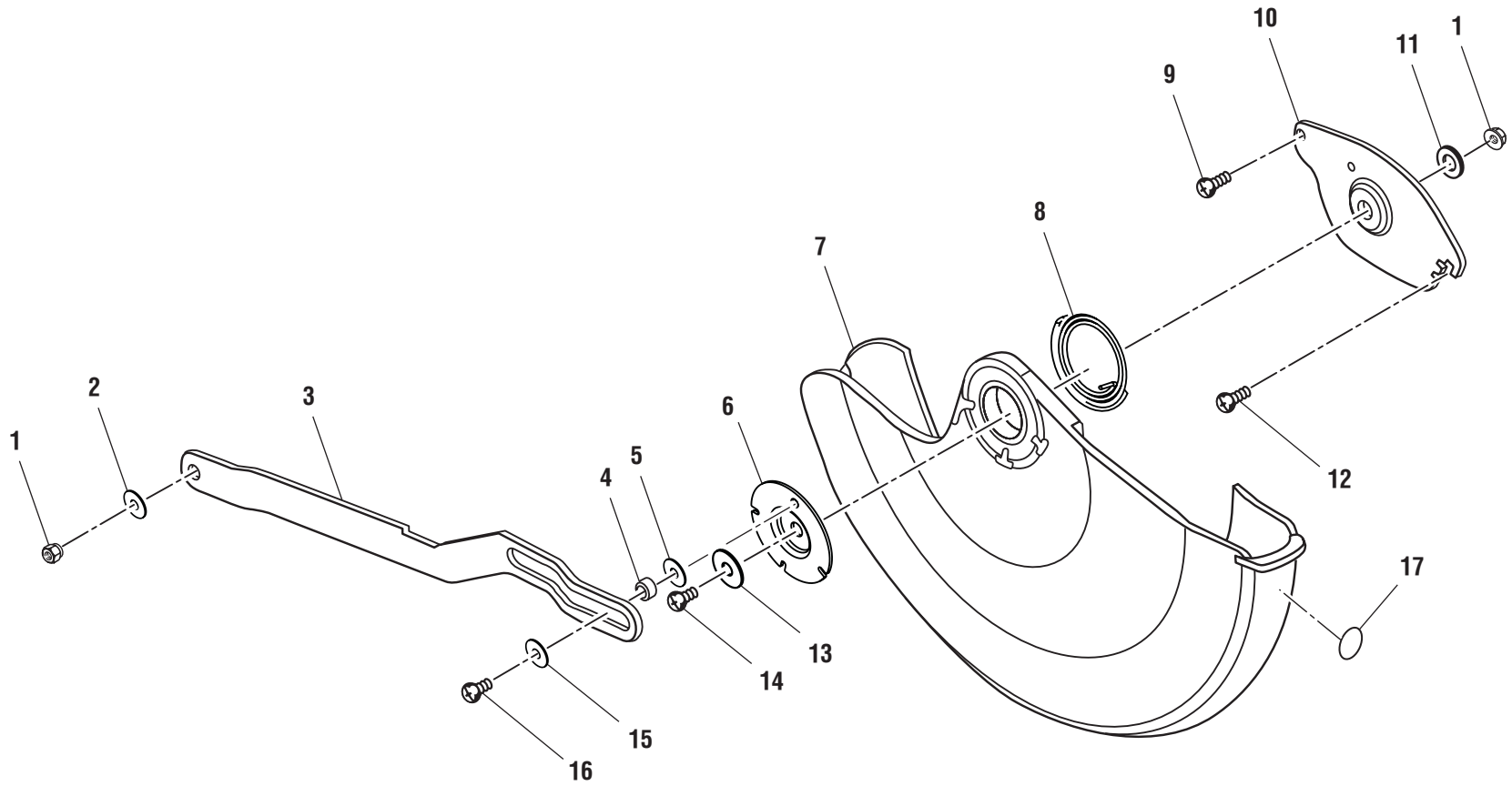

RIDGID 12 in. COMPOUND MITER SAW – MODEL NUMBER MS1250LZ

The model number will be found on a plate attached to the motor housing. Always mention the model number in all correspondence regarding your **MITER SAW** or when ordering repair parts.

PARTS LIST FOR FIGURE E

Key No.	Part Number	Description	Qty.
1	817449-1	LOCK NUT (M6 X 1.0 mm)	2
2	820238-5	WASHER.....	1
3	823340-1	ACTUATOR LINK.....	1
4	820725-01	SPACER (7 X 10 X 4)	1
5	820732-2	WASHER.....	1
6	826879	GUARD RETAINER	1
7	830530	LOWER GUARD	1
8	816677	GUARD SPRING.....	1
9	821873	SCREW (10-32 X .50 SHOULDER).....	1
10	830529	LOWER GUARD PIVOT	1
11	828141	WASHER.....	1
12	020123008	SCREW (10-32 X 1/2 in. PAN HD)	1
13	827409	BEARING RETAINER.....	1
14	828142	SCREW (M6 X 1.0-13 mm FLAT HD).....	1
15	820732-1	WASHER.....	1
16	820724-01	SCREW (M5 X 0.8-16 mm SHOULDER).....	1
17	867227001	NO HANDS WARNING LABEL	1

FIGURE F

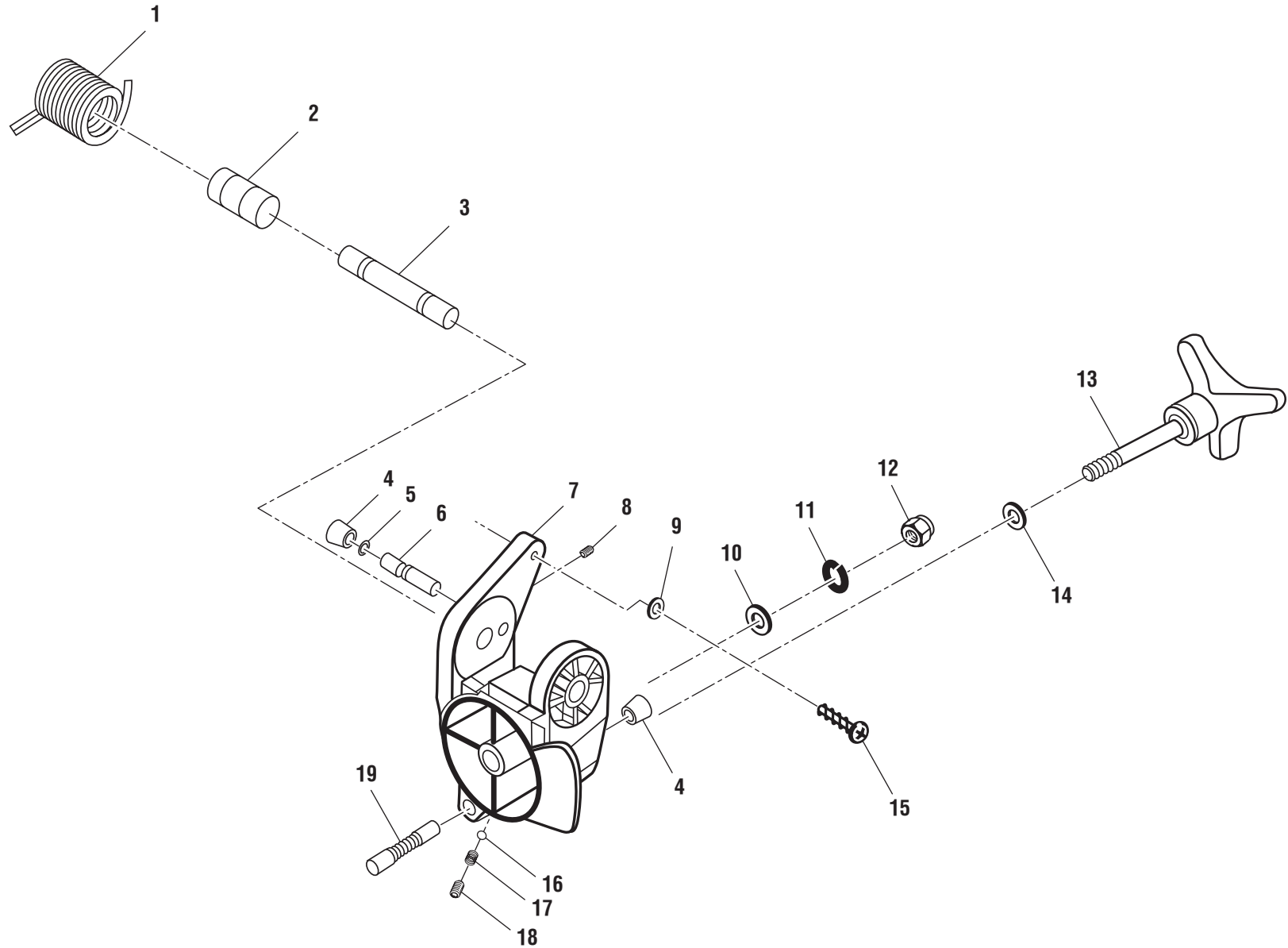

RIDGID 12 in. COMPOUND MITER SAW – MODEL NUMBER MS1250LZ

The model number will be found on a plate attached to the motor housing. Always mention the model number in all correspondence regarding your **MITER SAW** or when ordering repair parts.

PARTS LIST FOR FIGURE F

Key No.	Part Number	Description	Qty.
1	828066	TORSION SPRING	1
2	823320	TORSION SPRING SPACER	1
3	823344	PIVOT SHAFT ARM	1
4	828034	RUBBER CAP	1
5	821421-2	O-RING	1
6	828035	LOCKING PIN	1
7	828107-1	PIVOT	1
8	828120	SCREW (M4 X 0.7-5 mm SET LOCK).....	1
9	821063-1	WASHER.....	1
10	828117	WASHER.....	1
11	819179	WASHER SPRING	1
12	818656	LOCK NUT (M12).....	1
13	827488	BEVEL KNOB	1
14	828170	WASHER.....	1
15	821875-4	SHOULDER SCREW (M6 X 23 mm).....	1
16	823742-2	BALL (5 mm).....	1
17	828039	SPRING	1
18	828040	SCREW (M6 X 1.0-10 mm SET LOCK).....	1
19	828041-1	BEVEL INDEX PIN	1
	983000578	OPERATOR'S MANUAL	
	6-22-09		
	(REV:05)		