

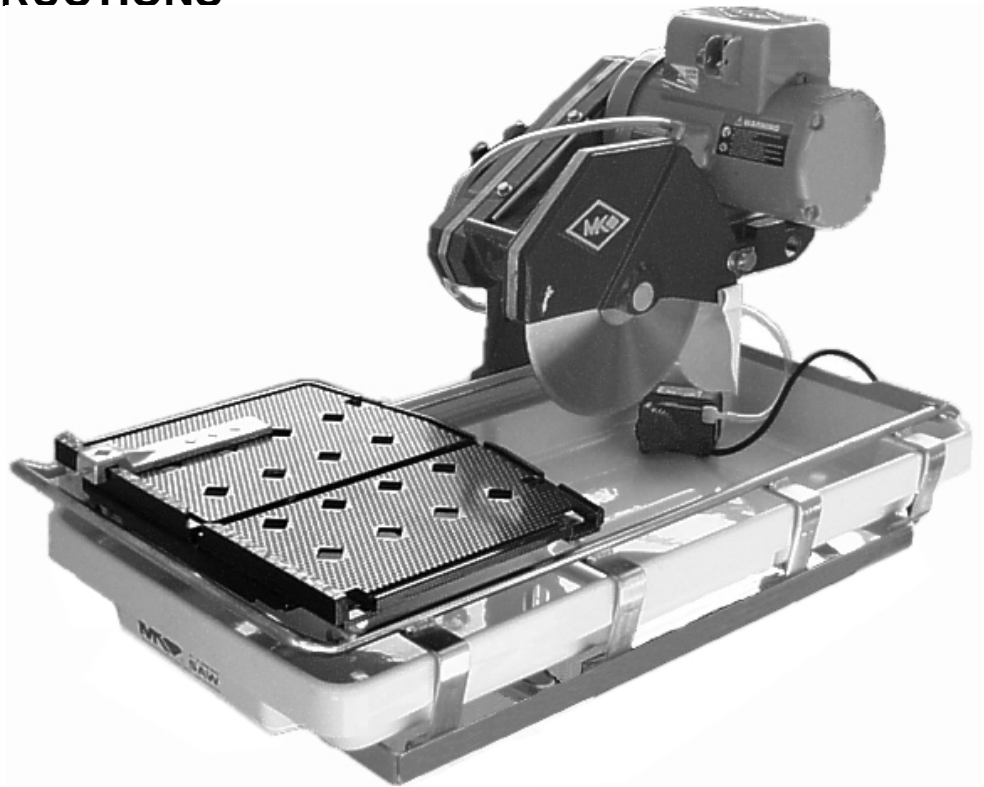

MK-100 TRACKER

**TILE SAW
OWNER'S MANUAL &
OPERATING INSTRUCTIONS**



CAUTION:
Read all safety and
operating instructions
before using this
equipment

Enter the Serial Number of your new saw in the space below. The Serial Number is located on the left side of the blade guard.

SERIAL NUMBER:

NOTE:

For your (1) one year warranty to be effective, complete the warranty card (including the Serial Number and mail it in as soon as possible.

EXPLODED VIEW AND PARTS LIST

EXPLODED VIEW:

CUTTING HEAD ASSEMBLY (F-J), P/N 158478

MK-101 TRACKER SAW, EXPLODED VIEW

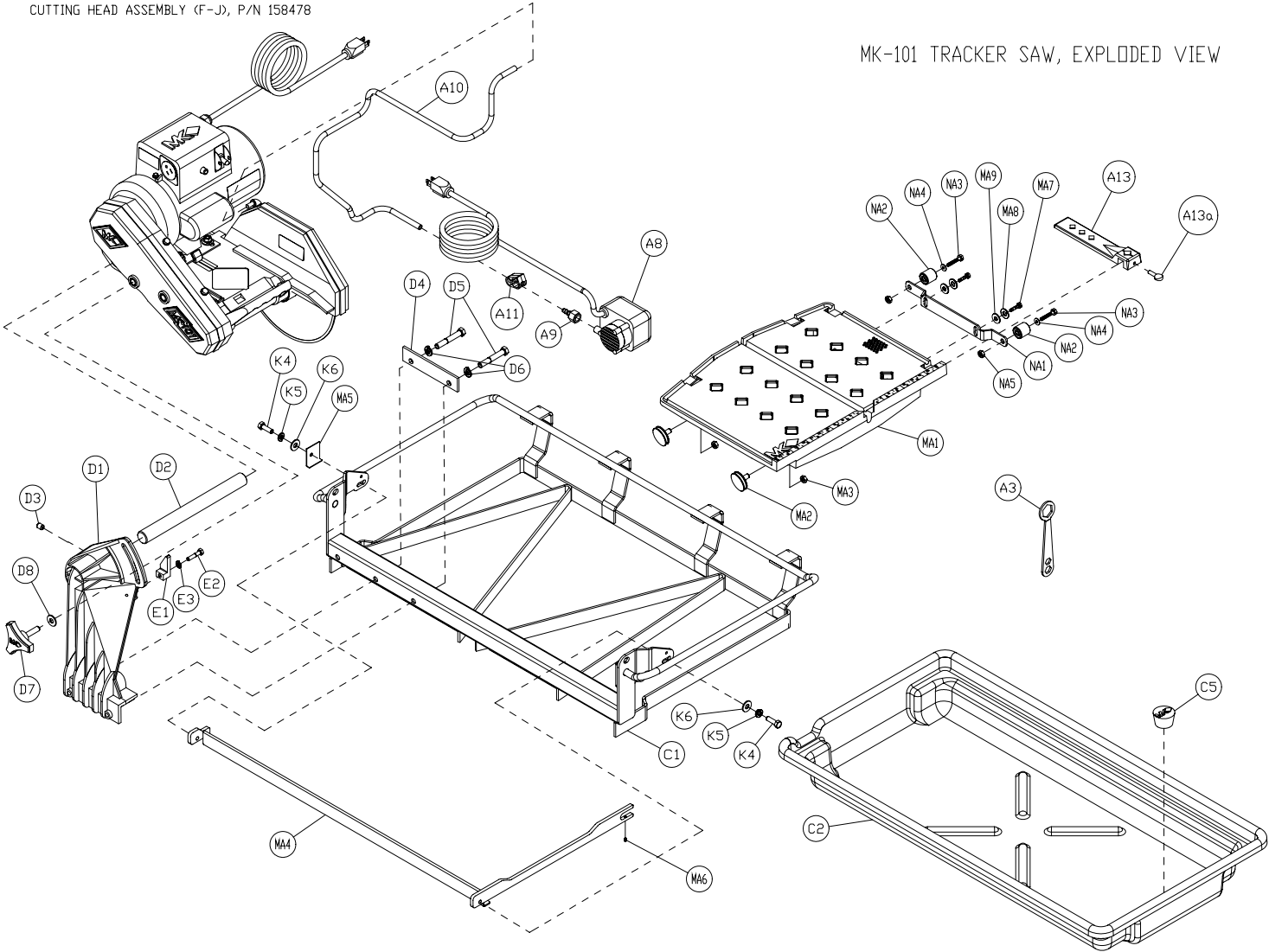

EXPLODED VIEW AND PARTS LIST

PARTS LIST:

Item	Description	Qty	Part #
A	Accessory Pack	-	n/a
A1	Wrench, 15/16 Closed End	1	134684
A2	Curtain, Splash	1	134841
A3	Bracket, Splash Curtain	1	152571
A4	Wingscrew, 1/4-20 X 1/2	1	151888
A5	Washer, 1/4 SAE Flat	1	151915
A6	Pump, 115v Water	1	151271
A7	Fitting, Plastic, 1/4 FNPT X 1/4 BARB	1	128397
A8	Hose, Vinyl, 1/4 ID	2'	132951
A9	Clamp, Flow, 1/4-1/2	1	154394
A10	Owner's Manual, Water Pump	1	155745
A11	Rip Guide (comp)	1	134551
A11a	Screw, 1/4-20 X 3/4 Thumb	1	150991
A12	Blade, MK-100, 10 X 060 X 5/8	1	154380
A13	Owner's Manual, MK-100 TRACKER	1	-
A14	Carton, Accessory Pack, 101	1	153366
A15	Foam, Accessory Pack Carton	1	154022
A16	Card, MK Warranty Registration	1	155037
A17	Label, Do Not Return	1	157063
A18	Sell Sheet, Tile Accessory	1	156915
B	Carton	-	n/a
B1	Carton, 100	1	158541
B2	Insert, Carton, Cutting Head	2	158542-1
B3	Insert, Carton, Accessory Pack	1	158542-2
B4	Pallet, 101, Plastic	1	158767
C-E	Assembly, Frame	-	n/a
C	Frame		n/a
C1	Frame, 101	1	153003
C2	Pan, Plastic, 101	1	150634
C3	Pin, 3/16 X 3/8 Roll	2	151783
C4	Plate, Adjustment	2	151758
C5	Plug, Rubber Drain	1	153439
D	Post		n/a
D1	Post, DC, 101, MK Red (comp)	1	158438
	Post, DC, 101 (raw)	1	158437
D2	Shaft, 10.63" Pivot, 101	1	153254
	Steel, 1 Dia C1045 CDS	.92'	156193
D3	Screw, 3/8-16 X 1/2 Socket Head Set	1	153710
D4	Plate, Support	1	155671
D5	Screw, 3/8-16 X 2 1/2	2	156030
D6	Washer, 3/8 Split Lock	2	150925
E	Stop, Cutting Head	-	-
-	Kit, Stop, 10" Cutting Head	1	157728-MK
E1	Stop, 10" Cutting Head	1	157728
E2	Screw, 1/4-20 X 1 1/4 Hex Head Cap	1	157145
E3	Washer, 1/4 Split Lock	1	152591

EXPLODED VIEW AND PARTS LIST

Item	Description	Qty	Part #
F-J	Assembly, 115V Cutting Head, MK-100	1	158225
F	Belt Guard		n/a
F1	Belt Guard, MK-100 (comp)	1	158319-00
	Belt Guard, MK-100 logo (raw)	1	158318-00
	Insert, 3/8-16 AVK	2	158193
F2	Bracket, Inner Belt Guard, 100/101/101Pro	1	158611
F3	Screw, 1/4-20 x 3/4 Hex Head Cap	3	152370
F4	Screw, 1/4-20 x 1 Hex Head Cap	1	152676
F5	Washer, 1/4 Split Lock	4	152591
F6	Washer, 1/4 SAE Flat	4	151915
F7	Belt, 260J6 Micro-V	1	158194
F8	Knob, 3/8-16 X 1.5 MK Adjustment	1	156770-2
F9	Washer, 3/8 SAE Flat	1	150923
G	Blade Guard	1	n/a
G1	Blade Guard, 101/115 (comp)	1	153659
	Blade Guard, MK logo (raw)	1	152508
G2	Elbow, 1/8 MNPT X 1/4 BARB 90° Brass	1	154652
G3	Tube, Water	2	155389
	Tubing, Stainless Steel 1/4 OD X .028 wall	.75'	152579
G4	Screw, 5/16-18 X 1/2 Socket Head Set	3	152607
G5A	Label, Tile saw Serial #, No Mark	1	157249-01
H	Subassembly, 115V Cutting Head, MK-100	1	158191
H1	Head, 10" Cutting (comp)	1	158224
	Head, 10" Cutting (raw)	1	158223
H2	Pin, Blade Shaft Lock	1	158200
H3	Spring, Blade Guard Lock	1	158201
H4	E-Ring, 1/4 Retaining	1	158202
H5	Bearing, 17mm X 40mm X 12mm Ball (6203-2NSE)	2	137711
H6	Shaft, Blade 880/101/1080	1	158222
	Steel, 3/4 Dia C12L14	1'	154188
H7	Flange, 2-3/8 Inner	1	137737
	Steel, 2-3/8 Dia C12L14	.09'	154196
H8	Flange, 2-3/8 Outer	1	135830
H9	Nut, 5/8-18 Hex	1	135848
H10	Pulley, 6J19 X 5/8 Bore	1	158199
	Steel, 2.0 Dia C1215 CD	1.5"	154723
H11	Key, 3/16 x 3/16 x 1 1/8 Square	1	150344
H12	Screw, 5/16-18 X 3/8 Socket Head Set, Cup Point	2	157083
H13	Bumper, 1/2 Dia Rubber	1	152674
H14	Screw, 5/16-18 X 1 Hex Head Cap	4	151743
H15	Washer, 5/16 SAE Flat	4	151754
H16	Washer, 5/16 Split Lock	4	151747
H17	Nut, 5/16-18 Hex	4	101196
H18	Screw, 5/16-18 x 2 1/2 Hex Head Cap, Full Thread	1	151748
H19	Pivot, Blade Guard	1	153208
H20	Washer, 3/8 SAE Flat	2	150923
H21	Wingnut, 5/16-18 Nylock	1	151746
H22	Strap, Motor Adjustment	1	152673
H23	Screw, 3/8-16 X 3 1/2 Hex Head Full Thread	1	153147

EXPLODED VIEW AND PARTS LIST

Item	Description	Qty	Part #
J	Assembly, 1.5hp/115V/60Hz GE Motor	1	158297
J1	Motor, 1.5HP\115V\60Hz GE	1	157980
J2	Casting, Conduit Box (comp)	1	157971
	Casting, Conduit Box (raw)	1	158077
J3	Gasket, Conduit Box / Motor	1	158213
J4	Screw, #12 X 5/8 Indented Hex Washer Slotted B	2	158335
J5	Cord, 14/3 SJTW X 5-15P X Power	1	158205
J6	Cord, 18/3 SJTW X 5-15R Pump	1	158253
J7	Switch, 20A DPST Toggle, w/ QD Terminals	1	154310
J8	Plate, Toggle Switch Lockout	1	158211
J9	Boot, Toggle Switch	1	154301
J10	Pulley, 6J17 X 5/8 Bore	1	158214
	Steel, 1.75 Dia C1215 CD	1.5"	155342
J11	Key, 3/16 x 3/16 x 1-1/8 Square	1	150344
J12	Screw, 5/16-18 X 3/8 Socket Head Set, Cup Point	2	157083
J13	Label, Warning, Read Owner's Manual, 1-3/4 X 3-3/8	1	155806
J14	Label, Caution, GFCI, 1 X 2 1/8	1	155678
J15	Label, Caution, 5 Amp Max., 1 X 2-1/8	1	154822
J16	Label, MK Service Info., 2 1/8 X 1-13/16	1	155038
J17	Screw, 10-32 X 3/8 Hex Washer Head Grounding	1	158209
J18	Washer, #10 Internal Tooth Lock	2	158336
J19	Tie, 12 X #10 Clamp	1	158210
J20	Screw, 10-32 X 1 Socket Head Set, Cup Point	1	158254
J21	Nut, 10-32 Hex	2	156269
J22	Washer, 1/2 Internal Tooth Lock	1	158337
J23	Capacitor, 50mF Run, w/ QD Terminals	1	158242
J24	Terminal, 16-14 X .250 90° Female Spade	1	158798
J25	Capacitor, 270-324mF Start, w/ QD Terminals	1	158206
J26	Switch, Overload Protection	1	158207
K-M	Assembly, Tracker Wheel Table, MK	1	159554
KA	Table, Tracker Wheel	-	-
-	Assembly, Tracker Wheel Table	1	159554
KA1	Table, Tracker Wheel (comp)	1	158962
	Table, 100/101 (raw)	1	157597
KA2	Wheel, Conveyor Cart	2	133090
KA3	Nut, Hex w/ WSHR 5/16-18	2	153942
KA4	Frame, Tracker Wheel	1	158937
KA5	Stop, MK Tracker Wheel Table	1	159652
KA6	Screw, 10/24 x 1/4 Socket Set – Cup Point	2	157522
KA7	Screw, 5/16-18 x 3/4 Hex Head Cap	4	151369
KA8	Washer, 5/16 Split Lock	4	151747
KA9	Washer, 5/16 SAE Flat	4	151754
MA	Dual Roller Wheel	-	-
MA1	Assembly, Dual Roller Wheel	1	159549
MA2	Bracket, Dual Roller Wheel	1	159548
MA3	Wheel, Roller	2	151799
MA4	Screw, 1/4-20 X 1 1/2 Hex Head Cap	2	151914
MA5	Washer, 1/4 SAE Flat	2	151915
MA6	Nut, 1/4-20 Hex	2	151893
MA7	Shim, .004 X 5/16 ID X 1/2 OD	~4	152519