

LG24K54

Illustrated Parts List

"This machine is approved by the EPA for E10 (10% ethanol) and lower fuel only.
Do not use any fuel >E10 in this machine."

**TRACTOR - MODEL NO. LGT24K54 (96043012700), PRODUCT NO. 960 43 01-27
ELECTRICAL**

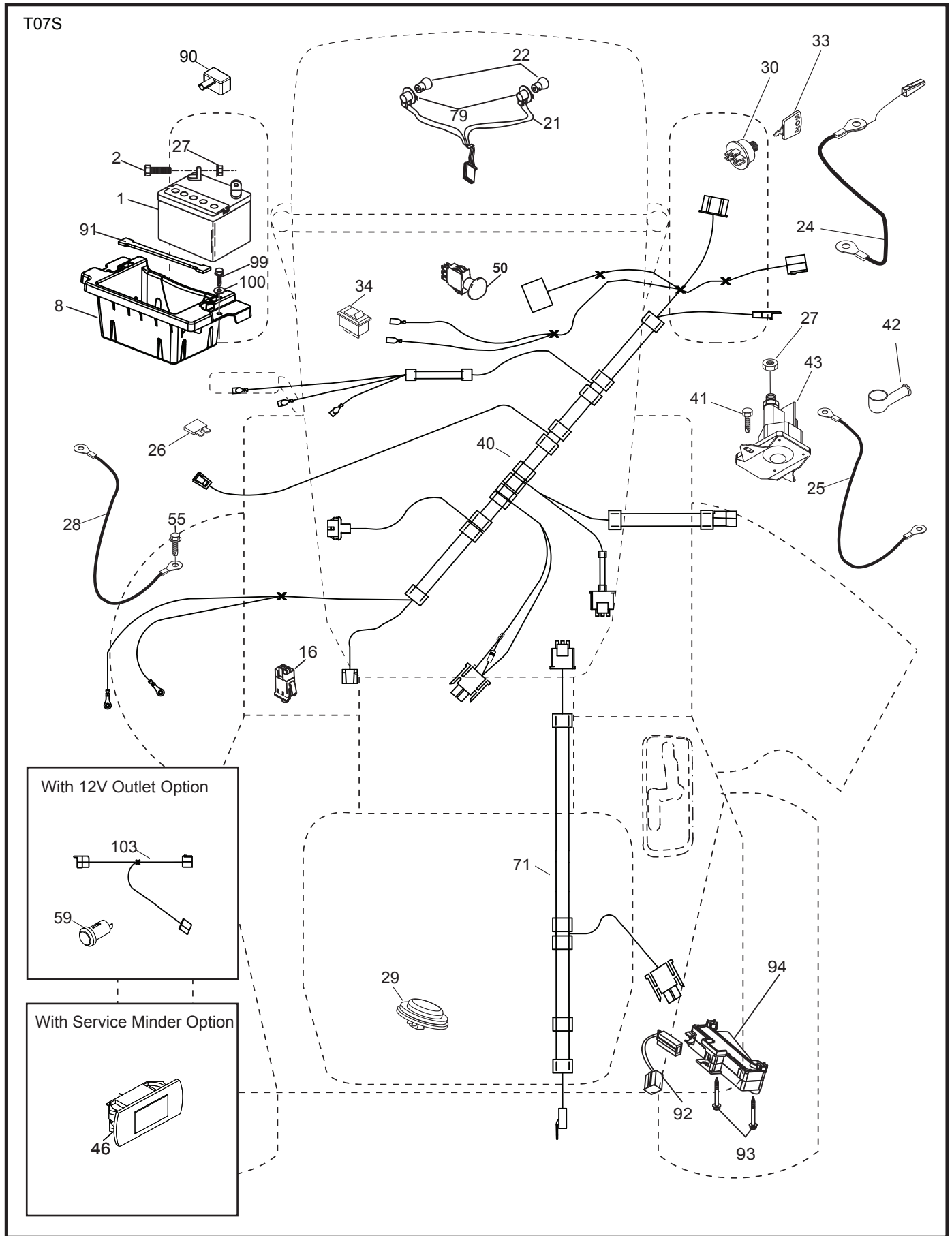

**TRACTOR - MODEL NO. LGT24K54 (96043012700), PRODUCT NO. 960 43 01-27
ELECTRICAL**

KEY NO.	PART NO.	DESCRIPTION
1	532 16 34-65	Battery
2	874 76 04-12	Bolt Hex Hd 1/4-20 unc x 3/4
8	532 18 64-91	Battery Box
16	532 17 61-38	Switch Interlock
21	532 40 02-52	Harness Socket Light
22	532 00 41-52	Bulb, Light # 1156
24	532 40 02-53	Cable Battery
25	532 41 28-95	Cable Starter
26	532 17 51-58	Fuse
27	873 51 04-00	Nut Keps Hex 1/4-20 unc
28	532 14 54-91	Cable Ground 21" Blk 6 Ga.
29	532 40 15-45	Switch Seat
30	532 19 33-50	Switch Ign
33	532 41 19-33	Key/Chain
34	532 11 07-12	Switch Light/Reset
40	532 40 11-04	Harness Ign. Dash
41	817 72 04-08	Screw Thd Cut 1/4-20 x 1/2
42	532 13 15-63	Cover Terminal Red
43	532 19 25-07	Solenoid
46	532 40 17-63	Gauge Hourmeter
50	532 17 46-51	Switch PTO
55	817 06 05-12	Screw Thdrol 5/16-18 x 3/4
59	532 40 03-03	Outlet 12-Volt
71	532 19 42-76	Harness Ign
79	532 17 52-42	Socket Asm Bulb Twistlock
90	532 43 53-95	Cover Terminal Battery
91	532 19 02-70	Strap Battery
92	532 19 66-15	Harness Pigtail Console ROS
93	532 19 25-40	Screw Plastite 10-14 x 2.0
94	532 19 18-34	Module Reverse ROS
99	817 67 04-12	Screw Hexwsh Thdrol 1/4-20 x 3/4
100	819 09 14-16	Washer 9/32 x 7/8 x 16 Ga.
103	532 40 79-62	Harness Pigtail 12V Outlet

NOTE: All component dimensions given in U.S. inches
1 inch = 25.4 mm

TRACTOR - MODEL NO. LGT24K54 (96043012700), PRODUCT NO. 960 43 01-27
CHASSIS

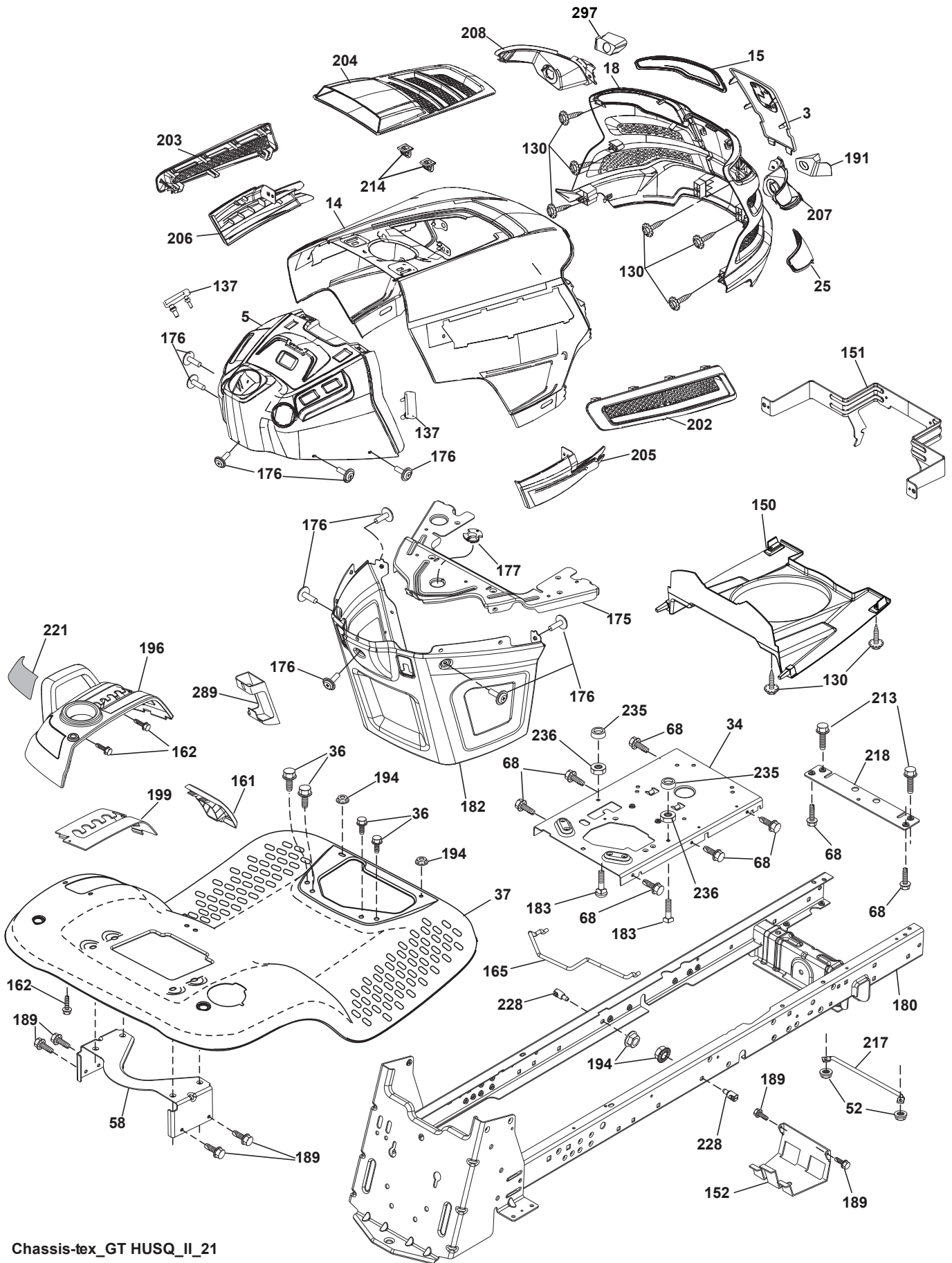

**TRACTOR - MODEL NO. LGT24K54 (96043012700), PRODUCT NO. 960 43 01-27
CHASSIS**

KEY NO.	PART NO.	DESCRIPTION
3	532 43 97-52	Logo
5	532 43 74-72	Dash
14	532 43 97-25	Hood
15	532 43 97-33	Lens LH
18	532 43 77-62	Grille
25	532 43 97-32	Lens RH
34	532 19 61-25	Plate Engine
36	817 06 05-12	Screw 5/16-18 x 3/4
37	532 40 18-25	Fender
52	873 68-05-00	Nut Crown Lock 5/16-18
58	532 19 43-14	Bracket Fender
68	817 49 05-08	Screw 5/16-18 x 1/2
130	532 41 63-58	Screw #10 x 0.750 BOS Thread
137	532 40 75-90	Bumper Dash
150	532 43 97-74	Duct Air
151	532 43 66-70	Bracket Pivot
152	532 19 95-35	Shield Browning/Debris\
161	532 40 18-26	Console Fuel Window
162	532 14 24-32	Screw Hex Wsh Hi-Lo 1/4 x 1/2
165	532 19 68-26	Bracket Support Tank
175	532 19 63-04	Crossmember
176	532 40 07-76	Screw 10-24 x 5/8 Wshd Qdrx
177	532 19 52-27	Bushing Steering
180	532 19 54-77	Chassis
182	532 40 68-59	Dash Lower
183	874 52 05-20	Bolt 5/16-18 x 1-1/4

KEY NO.	PART NO.	DESCRIPTION
189	817 00 05-12	Screw 5/16-18 x 3/4
191	532 43 74-55	Insert Reflective RH
194	873 90 05-00	Nut Lock 5/16-18
196	532 40 02-99	Console Asm. Deck Lift
199	532 19 82-59	Plate Deck Lift
202	532 43 97-28	Vent Side Hood RH
203	532 43 97-27	Vent Side Hood LH
204	532 43 57-14	Vent Asm Hood Top
205	532 43 97-30	Skirt Hood Side RH
206	532 43 97-29	Skirt Hood Side LH
207	532 43 97-34	Bezel RH
208	532 43 97-35	Bezel LH
213	874 76 05-12	Bolt Hex Hd 5/16-18 unc x 3/4
214	532 19 91-45	Clip Retainer
217	532 40 91-67	Rod Pivot
218	532 19 63-95	Hood Stop X Piece
221	532 19 89-09	Reflector LH
228	532 19 51-61	Stud Fastener
235	532 40 61-29	Spacer Fender
236	873 93 05-00	Nut Center Lock 5/16-18 unc
289	532 40 35-71	Plug Cruise/Phone
297	532 43 74-56	Insert Reflective LH
--	532 44 10-83	Brush Guard

NOTE: All component dimensions given in U.S. inches
1 inch = 25.4 mm

**TRACTOR - MODEL NO. LGT24K54 (96043012700), PRODUCT NO. 960 43 01-27
DRIVE**

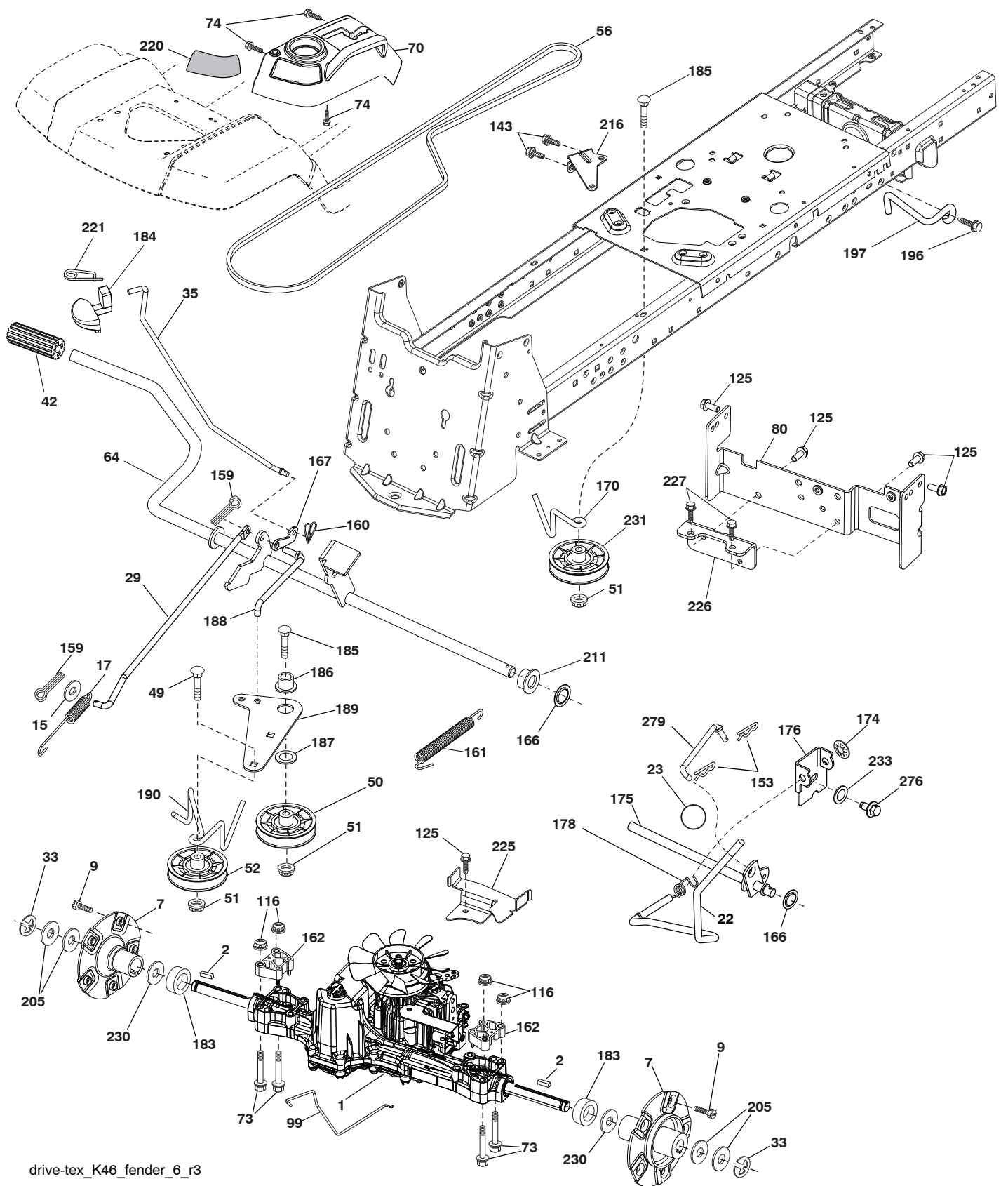

drive-tex_K46_fender_6_r3

**TRACTOR - MODEL NO. LGT24K54 (96043012700), PRODUCT NO. 960 43 01-27
DRIVE**

KEY NO.	PART NO.	DESCRIPTION	KEY NO.	PART NO.	DESCRIPTION
1	----	Transaxle, TUFFTORQ K46 AW	174	532 19 72-89	Nut Push
2	532 18 62-11	Key	175	532 40 62-08	Shaft Asm Shift
7	532 19 98-44	HubAsm. WheelRear22" TXGT.06	176	532 19 62-14	Arm Clevis Rod Shift
9	532 14 00-80	Bolt Hub Wheel Rear	178	532 19 74-56	Spring Shift
15	819 13 13-16	Washer 13/32 x 13/16 x 16 Ga.	183	532 40 04-24	Spacer Split
17	532 41 36-78	Spring Brake	184	532 40 31-18	Handle Parking Brake
22	532 19 73-29	Rod Shift	185	872 11 06-22	Bolt Rdhd Sqnk 3/8-16 x 2-3/4 Gr. 5
23	532 14 08-45	Knob	186	532 19 43-21	Spacer Retainer
29	532 40 38-06	Rod, Brake	187	819 13 32-10	Washer
33	812 00 00-01	Ring E	188	532 19 43-23	Link Clutch Ground Drive
35	532 43 54-86	Rod Brake Park	189	532 19 43-17	Bellcrank Ground Drive
42	532 12 48-72	Cover Foot Pedal	190	532 19 43-18	Keeper Bellcrank Ground Drive
49	872 11 06-14	Bolt	196	817 00 06-16	Screw 3/8-16 x 1
50	532 19 43-27	Pulley Idler Flat	197	532 19 97-69	Link Clutch Anti-Rotation
51	873 90 06-00	Lock Nut 3/8-16	205	532 12 17-48	Washer
52	532 19 43-26	Idler V-Groove 910" Offset	211	532 19 62-12	Bushing Brake Shaft
56	532 13 09-69	V-Belt Drive	216	532 19 61-31	Bracket Pulley Idler
64	532 19 62-00	Shaft Asm. Pedal Brake Control	220	532 19 89-08	Reflector RH
70	532 40 02-98	Console Asm.	221	532 40 31-87	Retainer Spring Clip Handle
73	874 49 05-60	Bolt Hex Flghd 5/16-18 x 3.75	225	532 40 33-19	Keeper Belt Trans.
74	532 14 24-32	Screw 1/4 x 1/2	226	532 40 08-31	Bracket Mount Torque
80	532 41 00-24	Strap Torque	227	817 49 05-12	Screw 5/16-18 x 3/4
99	532 41 57-43	Rod Bypass	230	532 18 89-67	Washer Hardened
116	873 90 05-00	Nut Lock Hex Flange 5/16-18	231	532 40 72-87	Idler V-Groove 1.688" Offset
125	817 00 05-12	Screw 5/16-18 x 3/4	232	874 78 07-16	Bolt 7/16-14 x 1 Gr. 5
143	817 49 05-08	Screw 5/16-18 x 1/2	233	532 40 52-96	Washer Serrated
153	532 12 47-88	Retainer Spring	279	532 40 62-07	Link Shift
159	876 02 04-12	Pin Cotter 1/8 x 3/4			
160	532 16 94-84	Retainer Clip			
161	532 10 57-09	Spring Return Clutch			
162	532 19 57-85	Spacer Transaxle 18 and 22			
166	532 42 83-05	Nut Push			
167	532 40 52-57	Latch Brake Parking			
170	532 41 34-30	Keeper Belt Centerspan			

NOTE: All component dimensions given in U.S. inches
1 inch = 25.4 mm

**TRACTOR - MODEL NO. LGT24K54 (96043012700), PRODUCT NO. 960 43 01-27
ENGINE**

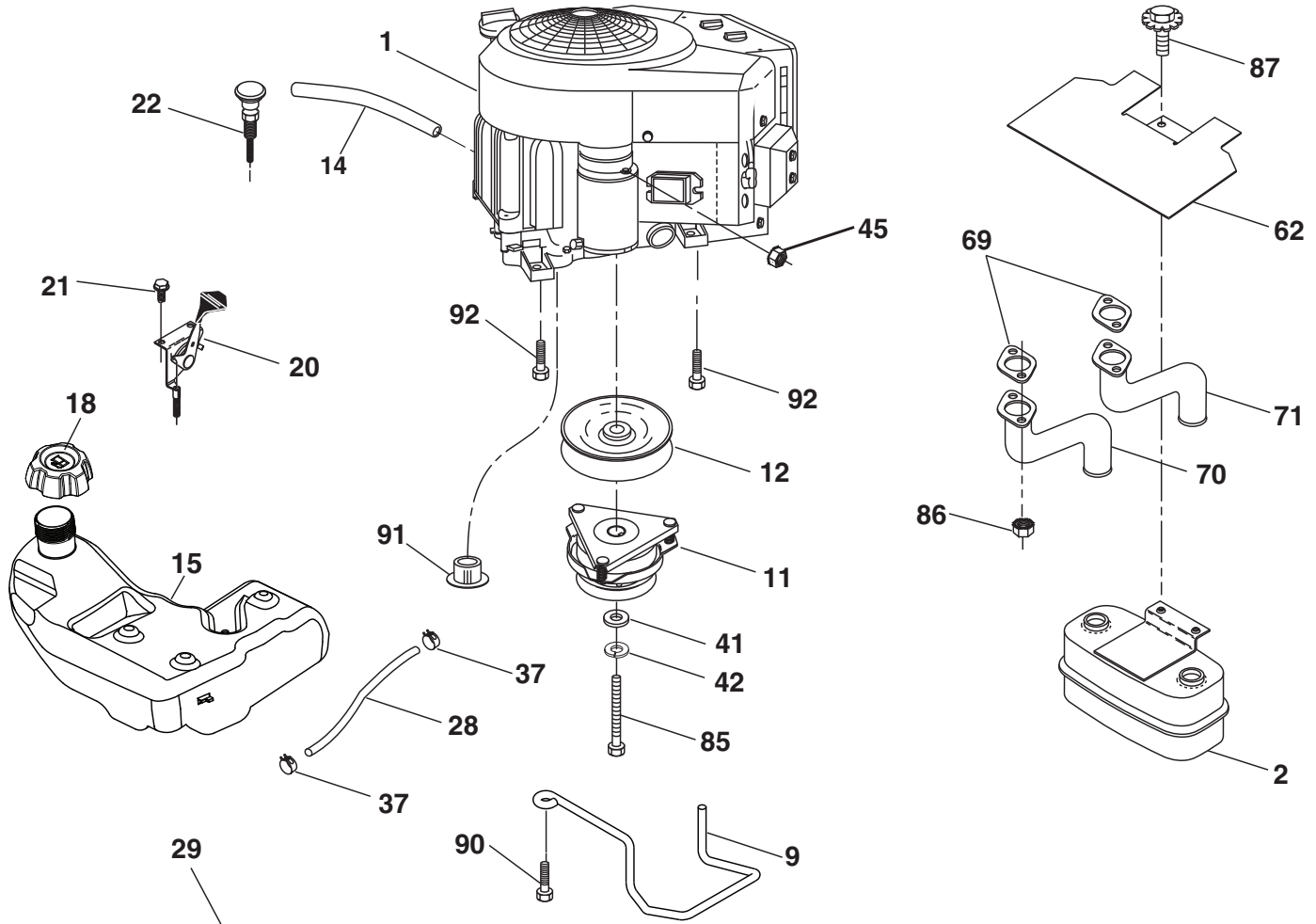

SPARK ARRESTER KIT

engine-tex_Kawa-2cyl_7

KEY NO.	PART NO.	DESCRIPTION
1	-----	Engine Kawa Model No. FR691V-AS06
2	532 14 97-23	Muffler
9	532 19 43-20	Keeper Belt Engine
11	532 17 93-35	Clutch Electric
12	532 19 43-43	Pulley Engine
14	532 14 84-56	Tube Drain Oil Easy
15	532 19 34-99	Tank Fuel 4.0
18	532 43 02-17	Cap Fuel
20	532 17 83-85	Control Throttle
21	532 41 63-58	Screw #10 x 0.750 BOS Thread
22	532 19 15-96	Control Choke
28	532 40 11-35	Fuel Line
29	532 13 71-80	Spark Arrester Kit
37	532 12 34-87	Clamp Hose
41	532 12 61-97	Washer 1-1/2 OD x 15/32 ID x .250
42	810 04 07-00	Washer Lock 7/16
45	873 51 04-00	Nut Keps Hex 1/4-20 unc

KEY NO.	PART NO.	DESCRIPTION
62	532 43 40-17	Shield Heat Muffler
69	532 17 81-51	Gasket
70	532 42 47-65	Tube Exhaust LH
71	532 42 47-66	Tube Exhaust RH
85	532 17 99-53	Bolt Hex 7/16-20 x 3.75 Gr. 5
86	532 18 43-62	Nut Hex Flange Toplock M8-1.25
87	532 19 82-39	Bolt 5/16-18 unc x 1 w/Sems
90	817 00 06-16	Screw 3/8-16 x 1
91	532 18 74-95	Bushing
92	817 12 06-16	Screw 3/8-16 x 1

NOTE: All component dimensions given in U.S. inches
1 inch = 25.4 mm
For engine service and replacement parts, call the toll free number for your engine manufacturer listed below:
Kawasaki 1-949-460-5688

TRACTOR - MODEL NO. LGT24K54 (96043012700), PRODUCT NO. 960 43 01-27

STEERING ASSEMBLY

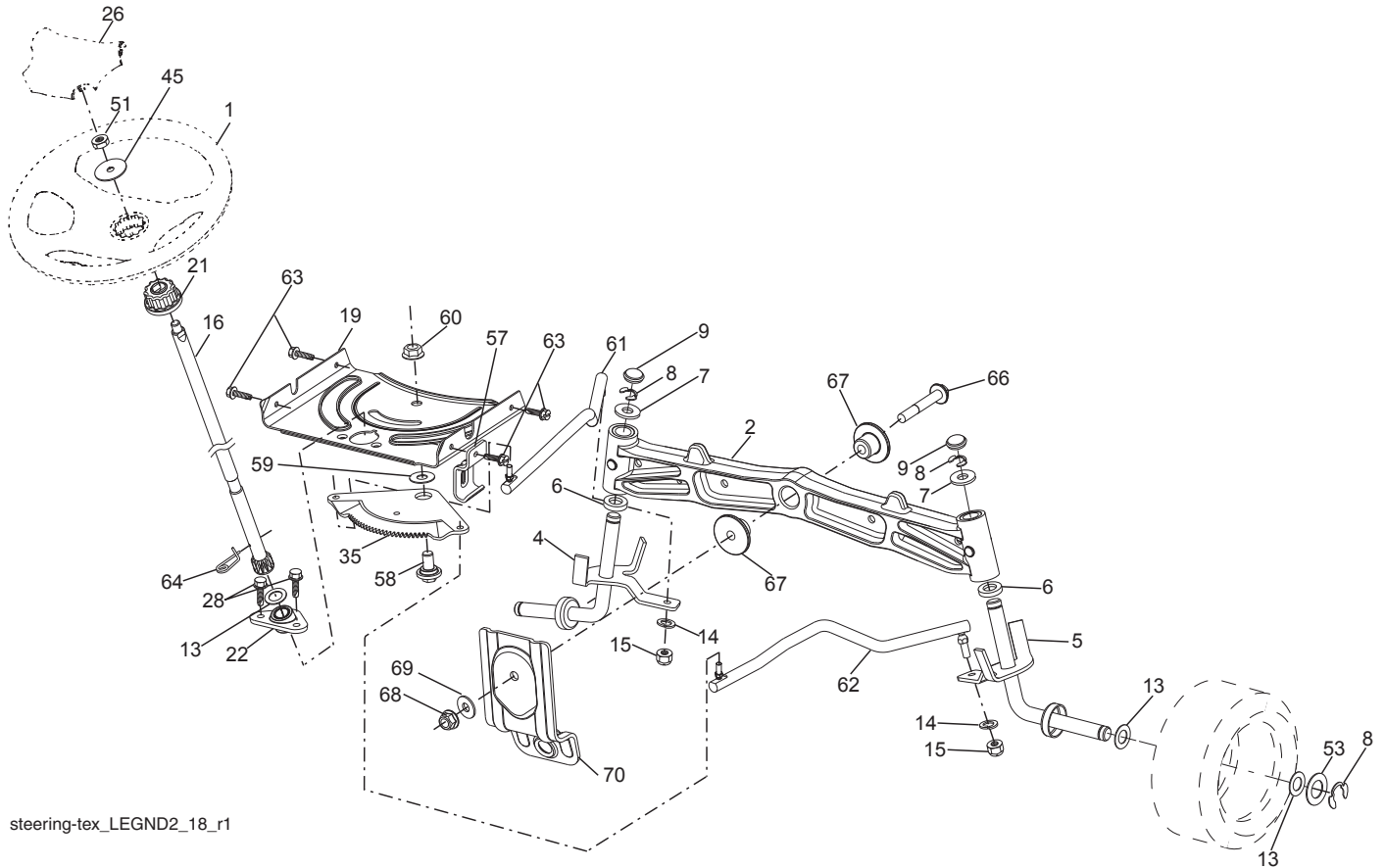

steering-tex_LEGND2_18_r1

KEY NO.	PART NO.	DESCRIPTION	KEY NO.	PART NO.	DESCRIPTION
1	532 43 99-97	Wheel, Steering	51	873 94 08-00	Nut Hex Jam Toplock 1/2-20 unf
2	532 19 59-68	Axle Asm., Front	53	532 18 89-67	Washer Hardened .793 x 1.637 x .060
4	532 40 30-89	Spindle Asm., LH	57	532 19 72-46	Bracket Upstop
5	532 40 30-90	Spindle Asm., RH	58	532 19 47-47	Bolt Shoulder Sector Pivot CFM
6	532 12 49-31	Bearing, Race Thrust Harden	59	532 19 47-48	Washer Thrust Sector Steering
7	532 12 17-48	Washer 25/32 x 1-5/8 x 16 Ga.	60	873 97 10-00	Nut Flange Lock 5/8-11
8	812 00 00-29	Ring, Klip #T5304-75	61	532 19 47-40	Draglink, LH
9	532 12 12-32	Cap, Spindle	62	532 19 47-41	Draglink, RH
13	532 12 17-49	Washer 25/32 x 1-1/4 x 16 Ga.	63	817 00 05-12	Screw 5/16-18 x 3/4
14	810 04 06-00	Washer, Lock Hvy Hlcl Spr 3/8	64	532 19 98-49	Retainer Clip Spring Steering
15	873 54 06-00	Nut, Crown Lock 3/8-24 unf	66	871 02 07-48	Bolt Hex Fghd 7/16-14 x 3 Serr
16	532 40 82-19	Shaft Steering	67	532 19 47-37	Bushing PM Front Axle
19	532 19 47-29	Plate Steering	68	873 90 07-00	Nut Lock Flange 7/16-14 Gr. 5
21	532 18 67-37	Adapter, Wheel Steering	69	532 19 91-62	Washer 1.5 x .505 x .118
22	532 42 05-37	Steering Support Lower	70	532 19 61-97	Bracket Deck Susp. Front
26	532 43 97-43	Insert, Wheel Steering			
28	817 00 06-12	Screw 3/8-16 x 3/4			
35	532 19 47-32	Gear, Sector Plate			
45	819 18 38-12	Washer 9/16 x 2-3/8 x 12 Ga.			

NOTE: All component dimensions given in U.S. inches
1 inch = 25.4 mm

**TRACTOR - MODEL NO. LGT24K54 (96043012700), PRODUCT NO. 960 43 01-27
DECALS**

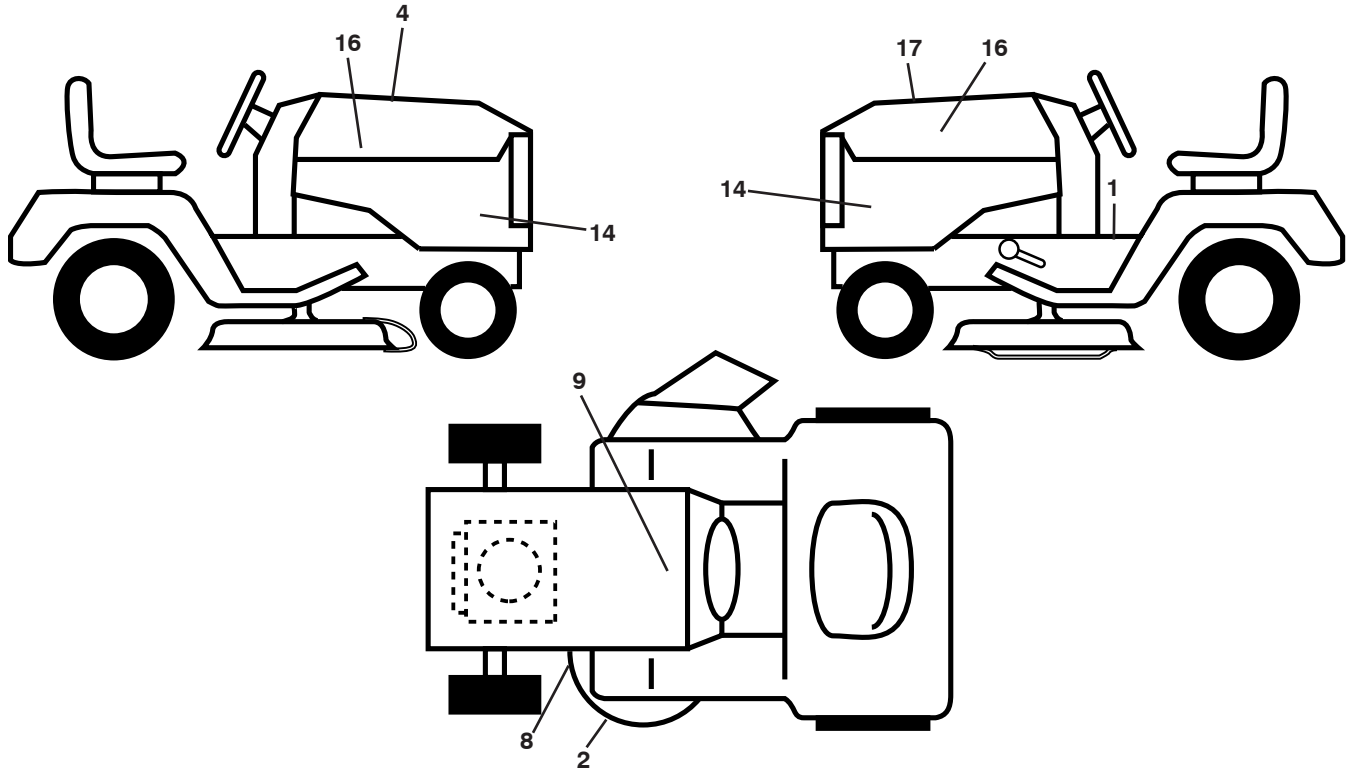

KEY NO.	PART NO.	DESCRIPTION
1	532 41 16-57	Decal, Fender Warning
2	532 17 84-55	Decal, Mower Caution
4	532 42 38-29	Decal, Hood Cust Resp
8	532 19 87-85	Decal, Mower Sch.
9	532 14 50-05	Decal, Battery Dnge/Poi
14	532 44 04-25	Decal, Panel Side
16	532 42 91-96	Decal, Hood Logo

KEY NO.	PART NO.	DESCRIPTION
17	532 43 84-83	Decal, Replacement
--	532 16 69-60	Decal, Bypass
--	532 40 17-71	Pad, Footrest, LH
--	532 40 17-70	Pad, Footrest, RH
--	532 44 04-19	Manual, Owner's (English)
--	532 44 10-48	Manual, Owner's (Spanish)

WHEELS AND TIRES

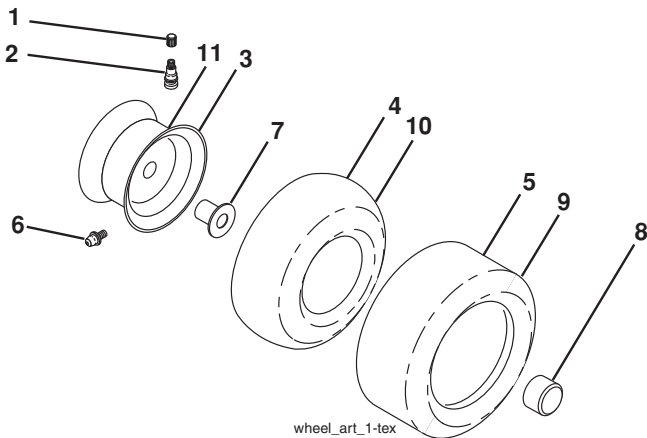

KEY NO.	PART NO.	DESCRIPTION
1	532 05 91-92	Cap, Valve, Tire
2	532 06 51-39	Stem, Valve
3	532 18 18-39	Rim Assembly, Front
4	532 00 81-34	Tube, Front (Service Item Only)
5	532 10 62-30	Tire, Front
6	532 12 49-57	Fitting, Grease (Front Wheel Only)
7	532 12 49-59	Bearing, Flange (Front Wheel Only)
8	532 17 50-39	Cap, Axle (Front Wheel Only)
9	532 18 47-08	Tire, Rear
10	532 00 71-54	Tube, Rear (Service Item Only)
11	532 40 17-82	Rim Assembly, Rear
--	532 14 43-34	Sealant, Tire (10 oz. Tube)

NOTE: All component dimensions given in U.S. inches
1 inch = 25.4 mm

**TRACTOR - MODEL NO. LGT24K54 (96043012700), PRODUCT NO. 960 43 01-27
SEAT ASSEMBLY**

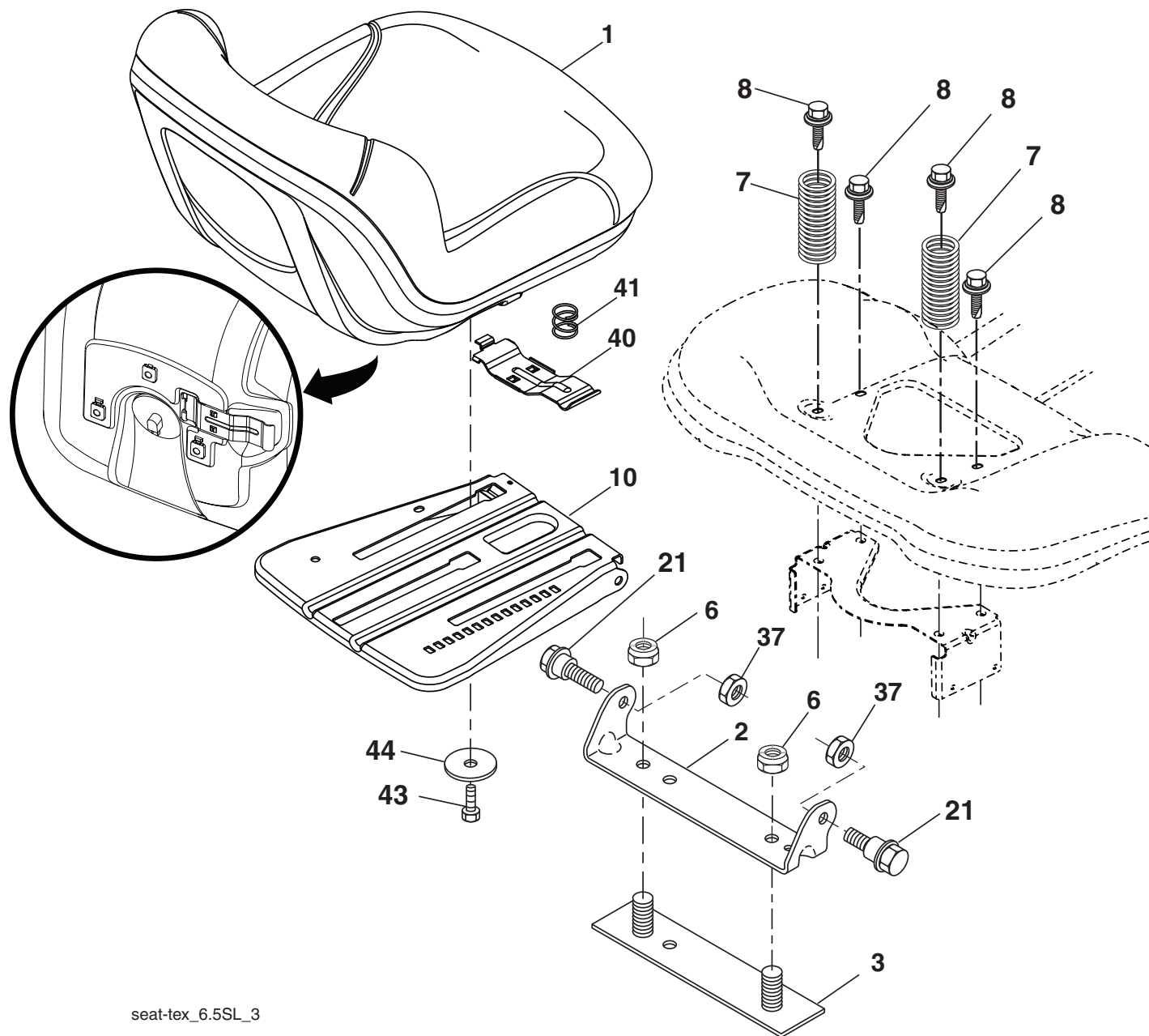

seat-tex_6.5SL_3

KEY NO.	PART NO.	DESCRIPTION
1	532 42 40-68	Seat
2	532 18 01-66	Bracket Pivot Fender
3	532 14 06-75	Strap, Asm Fender
6	873 80 06-00	Nut, Lock w/Ins. 3/8-16 unc
7	532 12 41-81	Spring, Seat Cprsn
8	532 17 18-77	Bolt 5/16-18 unc x 3/4 w/Sems
10	532 19 69-77	Pan, Seat
21	532 17 18-52	Bolt, Shoulder 5/16-18

KEY NO.	PART NO.	DESCRIPTION
37	873 80 05-00	Nut, Lock 5/16-18 unc
40	532 19 76-61	Handle Slide Seat
41	532 19 82-00	Spring Latch Seat
43	874 76 06-12	Bolt 3/8-16 x 3/4
44	819 13 38-12	Washer 13/32 x 2-3/8 x 12 Ga.

NOTE: All component dimensions given in U.S. inches
1 inch = 25.4 mm

TRACTOR - MODEL NO. LGT24K54 (96043012700), PRODUCT NO. 960 43 01-27
MOWER DECK

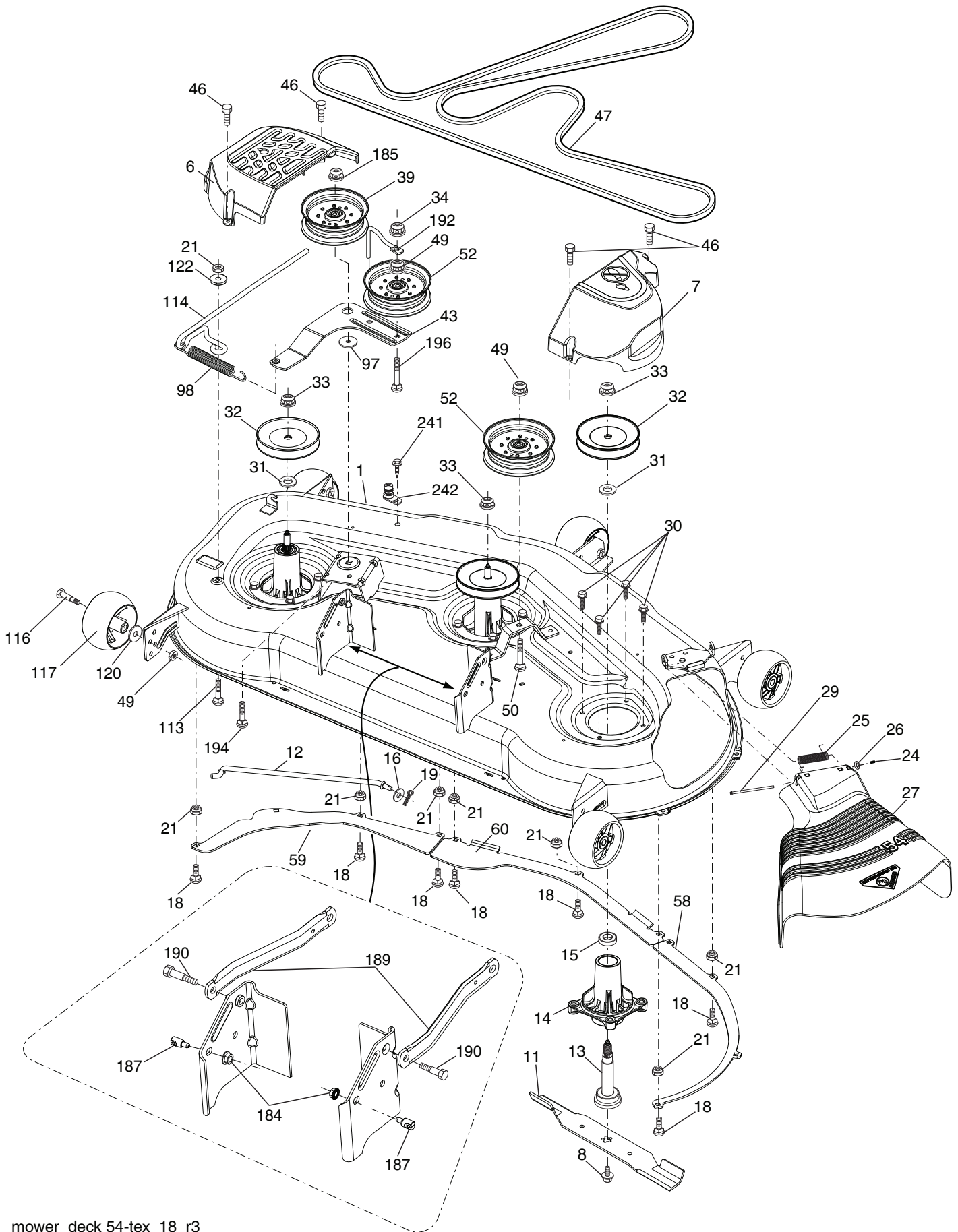

mower_deck 54-tex_18_r3

**TRACTOR - MODEL NO. LGT24K54 (96043012700), PRODUCT NO. 960 43 01-27
MOWER DECK**

KEY NO.	PART NO.	DESCRIPTION	KEY NO.	PART NO.	DESCRIPTION
1	532 40 31-25	Deck Weldment Mower	59	532 18 73-44	Baffle Left
6	532 19 60-66	Cover Mandrel LH	60	532 18 76-07	Baffle Center
7	532 19 71-81	Cover Mandrel RH	97	532 17 85-15	Washer Hardened
8	532 19 30-03	Bolt 7/16 Asm. Blade	98	532 19 61-05	Spring Drive
11	532 18 72-56	Blade Bagging	113	872 11 05-08	Bolt Rdhd Sqnk 5/16-18 x 3/4
12	532 40 48-51	Rod Anti-Sway	114	532 18 75-56	Rod Tension Relief
13	532 18 72-91	Shaft Asm. w/Lower Bearing	116	532 19 34-06	Bolt, Shoulder
14	532 18 72-81	Housing, Mandrel	117	532 17 48-73	Gauge Wheel
16	819 13 13-12	Washer 3/8	120	819 13 20-12	Washer 13/32 x 1-1/4 x 12 Ga.
15	532 11 04-85	Bearing, Ball, Mandrel	122	532 18 75-57	Bushing Tension Relief
18	872 14 05-05	Bolt Carriage 5/16-18 x 5/8	184	873 90 05-00	Nut Lock Hex Flange
19	532 19 42-08	Pin Cotter 5/16 Bowtie	185	873 90 07-00	Nut Lock Flange 7/16-14 Gr. 5
21	873 68 05-00	Nut, Crownlock 5/16-18 unc	187	532 19 51-61	Stud Fastener w/"D" Anti-Rotation
24	532 10 53-04	Cap Sleeve	189	532 19 51-85	Arm Susp. Mower Rear
25	532 17 81-02	Spring, Torsion	190	532 19 65-39	Bolt Shoulder
26	532 11 04-52	Nut, Push	192	532 19 84-68	Keeper Belt Idler
27	532 18 89-38	Deflector Shield	194	874 49 07-36	Bolt Hex Washer Head 7/16-24
29	532 13 14-91	Rod, Hinge	196	872 14 06-20	Bolt Rdhd 3/8-16 x 2-1/2 Gr. 5
30	532 17 39-84	Screw, Thdroll Washer Head	241	532 15 29-27	Screw #10-32.5 3/8 Flange
31	532 18 76-90	Washer, Spacer Mower Vented	242	532 41 55-98	Port Washout
32	532 15 35-35	Pulley, Mandrel	--	532 18 72-92	Mandrel Asm. Service Mandrel Assembly (Includes housing, shaft assembly, and bearing only - pulley/nut/washer and blade bolt/washers not included)
33	532 40 02-34	Nut, Flg. Top Lock	--	532 43 29-07	Replacement Mower, Complete
34	873 68 06-00	Nut Crownlock 3/8-16 unc			
39	532 19 73-80	Pulley, Idler, 4.50			
43	532 19 60-65	Arm, Idler			
46	532 13 77-29	Screw, Thdroll. 1/4-20 x 5/8			
47	532 19 61-03	Belt Deck Drive			
49	873 90 06-00	Nut, Lock Flg. 3/8-16 unc			
50	872 11 06-16	Bolt Rdhd Sqnk 3/8-16 unc x 2			
52	532 19 73-79	Pulley Idler			
58	532 18 73-42	Baffle Right			

NOTE: All component dimensions given in U.S. inches
1 inch = 25.4 mm

**TRACTOR - MODEL NO. LGT24K54 (96043012700), PRODUCT NO. 960 43 01-27
MOWER LIFT**

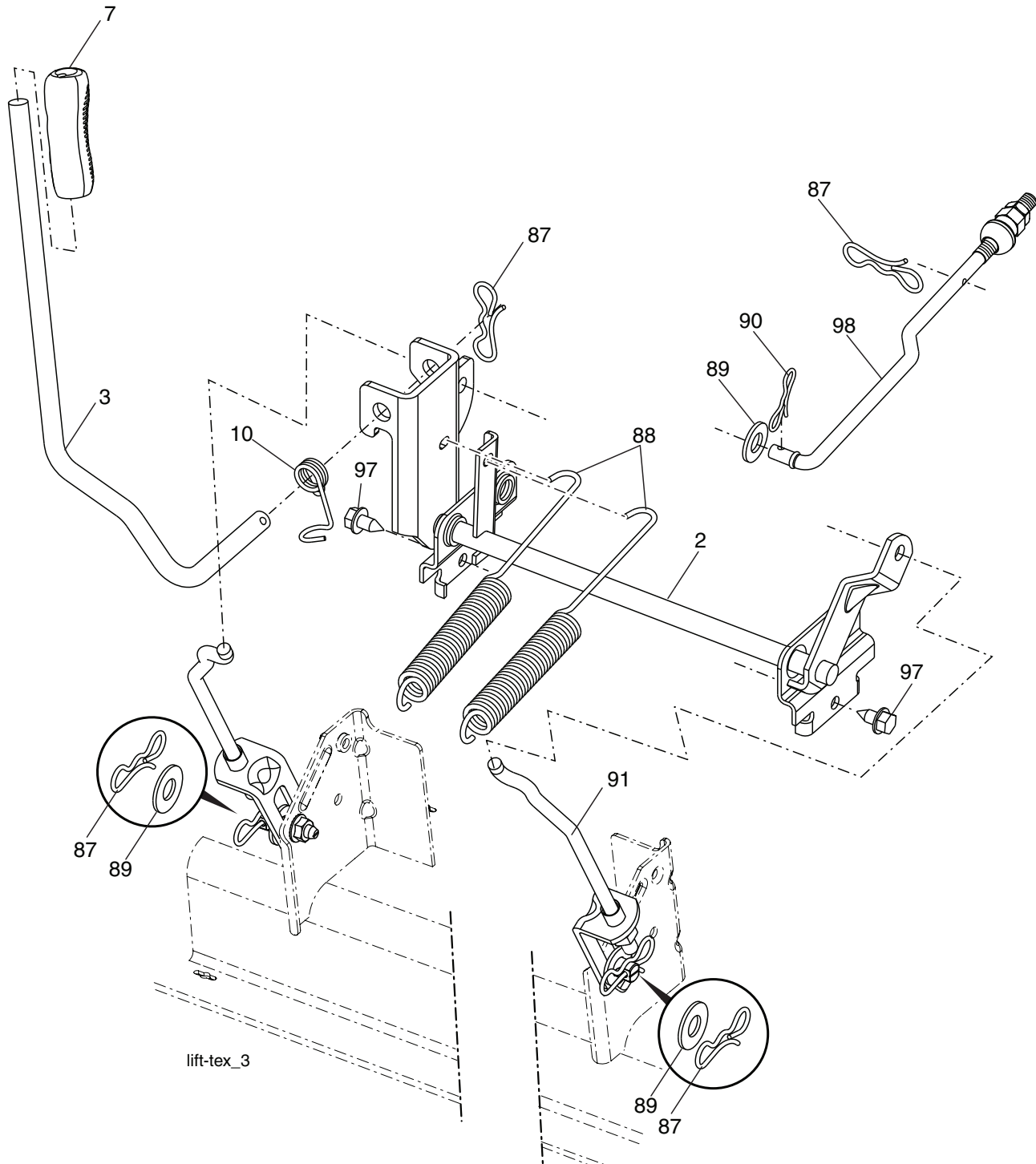

KEY NO.	PART NO.	DESCRIPTION
2	532 42 20-27	Shaft Asm., Lift
3	532 19 52-30	Lever Asm., Lift RH
7	532 41 15-55	Grip, Lever
10	532 19 63-14	Spring Torsion
87	532 19 42-09	Pin Cotter 7/16 Bow Tie Lock
88	532 19 53-04	Spring Lift Assist
89	819 19 19-12	Washer Clear Zinc

KEY NO.	PART NO.	DESCRIPTION
90	532 19 42-08	Pin Cotter 5/16 Bow Tie Lock
91	532 40 34-07	Link Lift Susp Mower Rear
97	817 00 06-12	Screw 3/8-16 x 3/4
98	532 19 52-64	Link Lift Susp. Front Mower

NOTE: All component dimensions given in U.S. inches
1 inch = 25.4 mm