

## K960 Ring

Reservdelar

Spare parts

Ersatzteile

Pieces de rechange

Piezas de repuesto

Ricambi

Peças sobresselente

**A** K960 RING

 Husqvarna

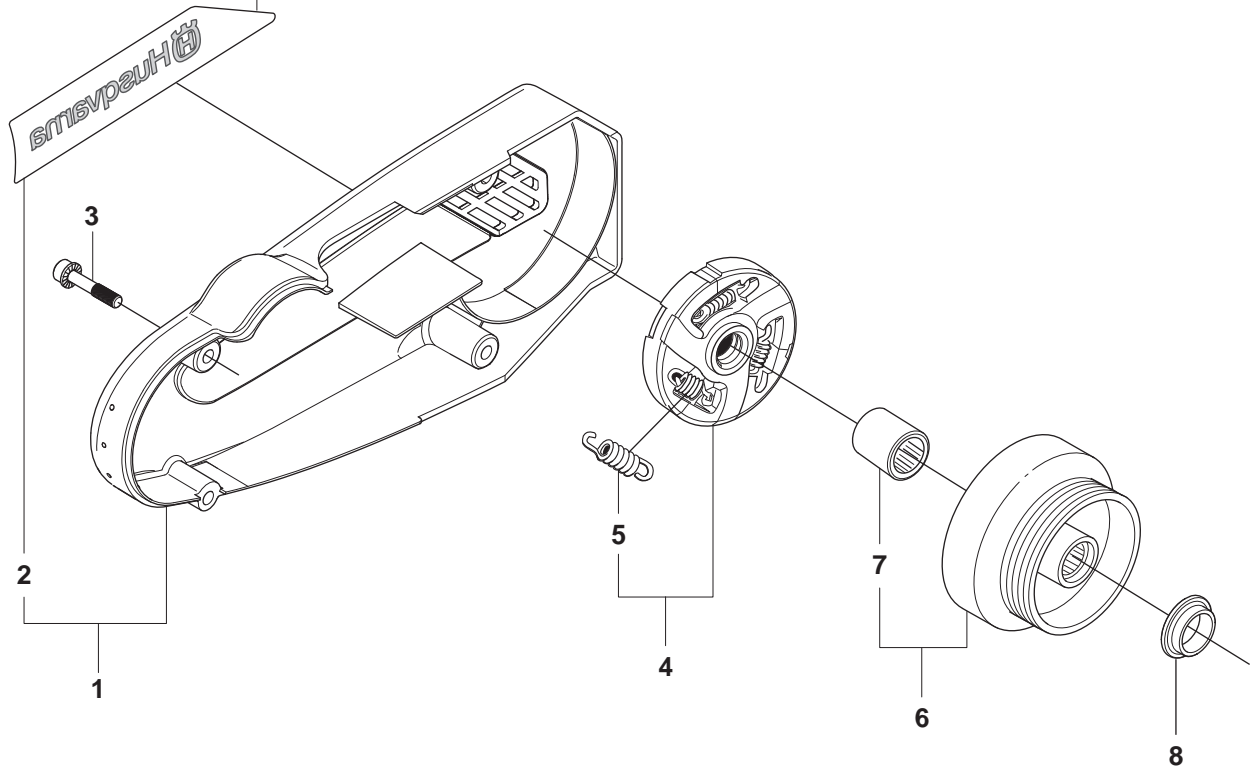

**Page A**  
**K960 Ring**

<b>Pos.</b>	<b>Part No.</b>	<b>Description</b>	<b>Quantity</b>	<b>Notes</b>	<b>New Part</b>
1	506 28 09-05	BELT GUARD	1	Incl. 2	
2	544 93 31-01	LABEL	1		
3	503 21 53-21	SCREW	4		
4	503 70 15-01	CLUTCH ASSY	1	Incl. 5	
5	503 14 51-01	CLUTCH SPRING	3		
6	506 28 01-02	DRIVING PULLEY ASSY	1	Incl. 7	
7	505 30 24-15	NEEDLE BEARING	1		
8	506 39 30-01	WASHER	1		

**B** K960 RING

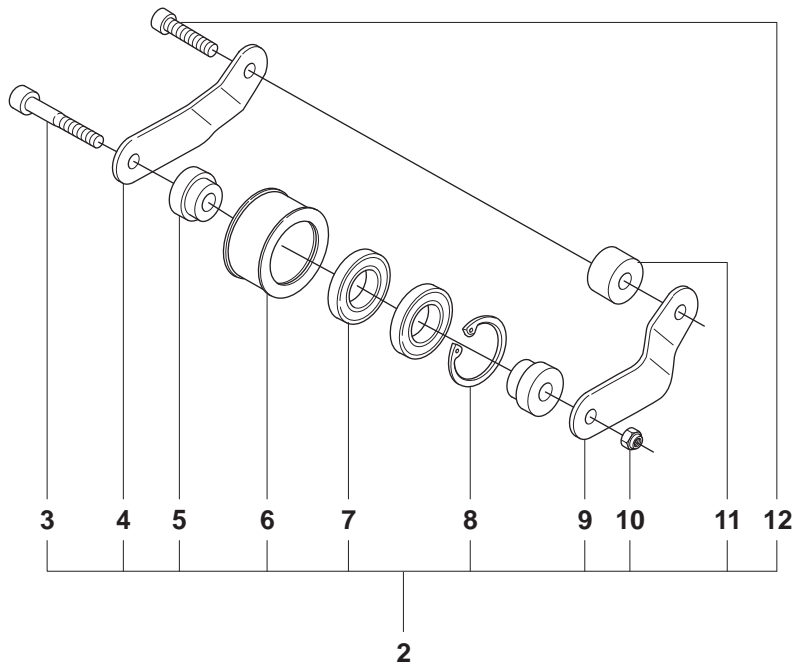
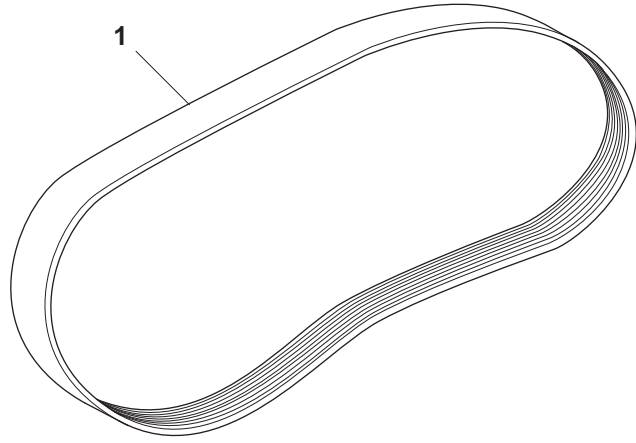

**Page B**  
**K960 Ring**

<b>Pos.</b>	<b>Part No.</b>	<b>Description</b>	<b>Quantity</b>	<b>Notes</b>	<b>New Part</b>
1	544 90 84-01	BELT	1		
2	506 28 06-05	BELT TENSIONER ASSY	1	Incl. 3 - 12	
3	544 21 84-37	SCREW	1		
4	506 33 53-02	LEVER	1		
5	506 33 52-01	SPACER	2		
6	506 33 51-01	ROLLER	1		
7	503 25 24-01	BALL BEARING	2		
8	735 31 28-10	CIRCLIP	1		
9	506 33 53-01	LEVER	1		
10	732 21 16-01	NUT	1		
11	506 33 54-01	SPACER	1		
12	544 21 84-01	SCREW	1		

# C K960 RING

← Decompression Valve  
Push before starting

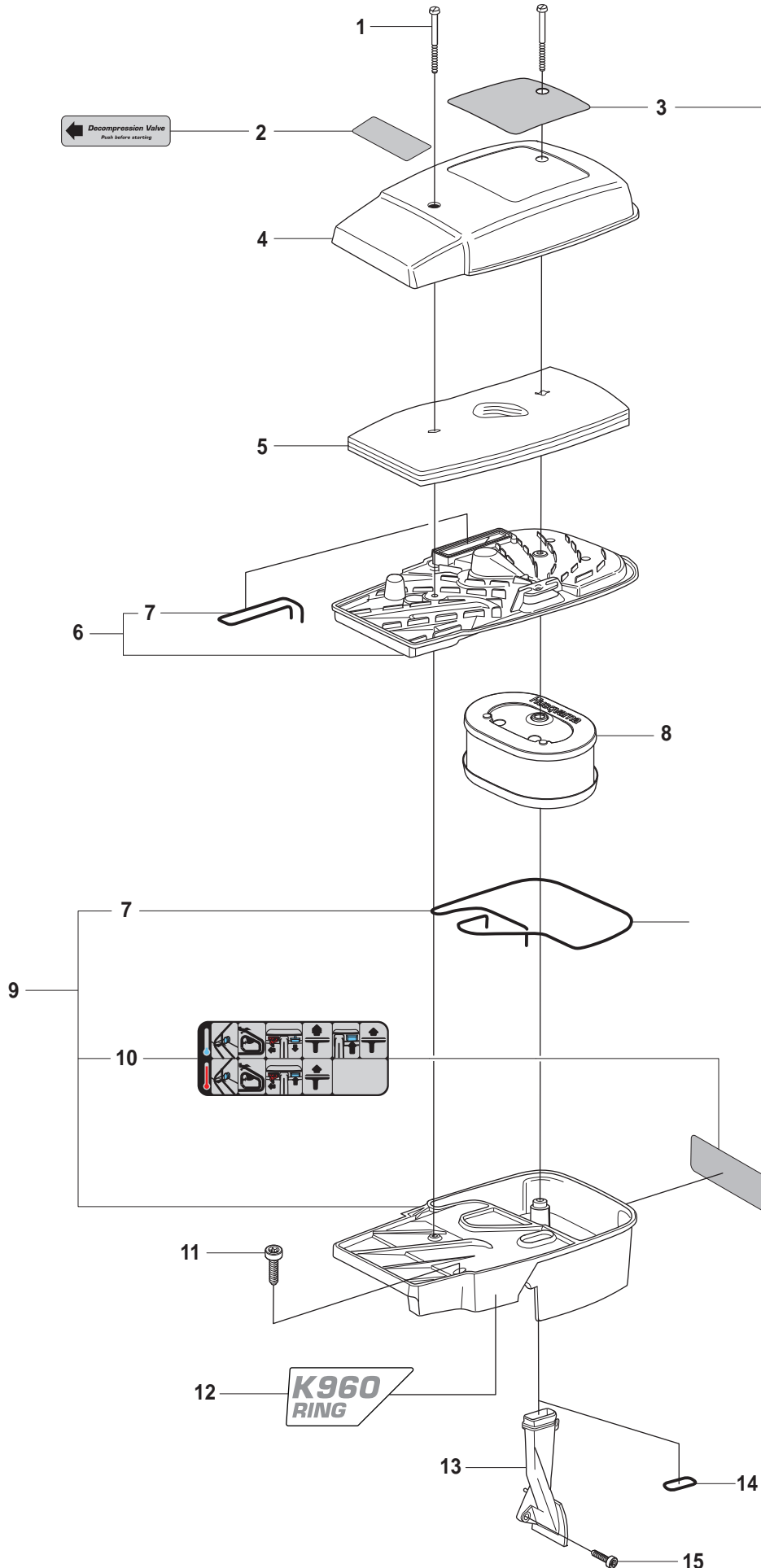

**Page C**  
**K960 Ring**

Pos.	Part No.	Description	Quantity	Notes	New Part
1	503 21 53-45	SCREW	2		
2	544 87 46-01	LABEL	1		
3	505 03 89-01	LABEL	1	EPA USA	
3	505 03 89-02	LABEL	1		
4	506 22 17-02	AIR FILTER COVER	1		
5	506 23 19-01	PREFILTER	1		
6	506 22 18-15	FILTER BOTTOM	1	Incl. 7	
7	506 28 39-30	SEALING	2	L=1,2 M. Cut to fit	
8	506 34 70-02	AIR FILTER	1		
9	544 89 14-02	CYLINDER COVER ASSY	1	Incl. 7, 10	
10	506 24 39-02	LABEL	1		
11	503 21 53-30	SCREW	3		
12	544 89 07-07	LABEL	1		
13	506 22 94-01	AIR NOZZLE	1		
14	740 48 20-03	O-RING	1		
15	501 98 10-01	SCREW	1		

**D** K960 RING

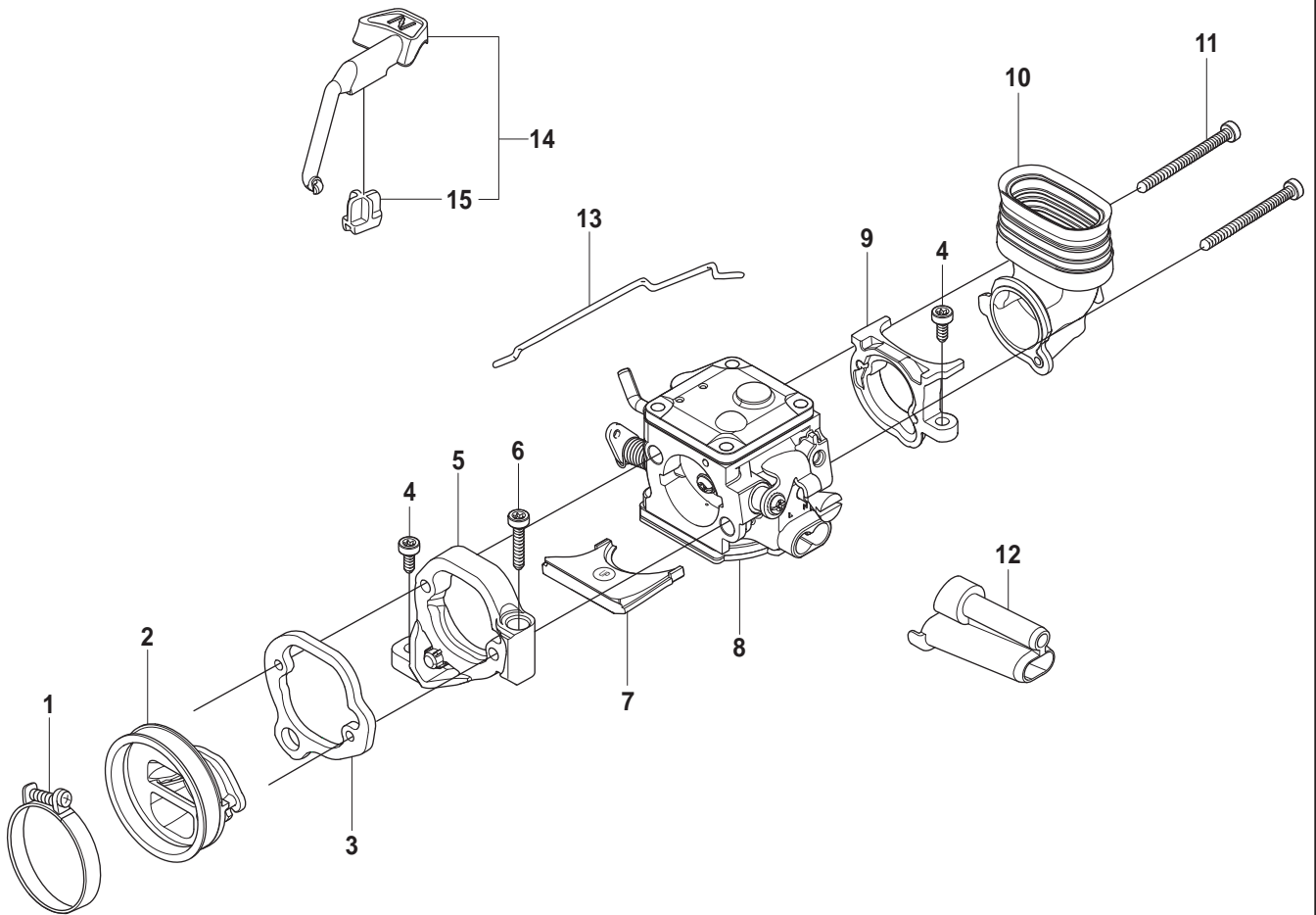



**Page D**  
**K960 Ring**

<b>Pos.</b>	<b>Part No.</b>	<b>Description</b>	<b>Quantity</b>	<b>Notes</b>	<b>New Part</b>
1	503 56 00-08	HOSE CLAMP	1		
2	506 41 41-01	INLET PIPE	1		
3	544 15 01-01	FLANGE	1		
4	503 21 53-16	SCREW	2		
5	544 11 39-01	CONSOLE	1		
6	503 21 53-30	SCREW	1		
7	506 41 42-01	PLATE	1		
8	502 62 32-01	CARBURETTOR	1	Walbro RWJ-3	
9	544 11 17-01	FLANGE	1		
10	544 33 19-01	INLET BEND	1		
11	501 97 18-01	SCREW	2		
12	544 23 26-01	CHISEL GUIDE	1		
13	505 44 31-01	THROTTLE ROD	1		
14	506 23 20-11	CHOKE	1	Incl. 15	
15	506 27 25-01	WEAR PROTECTION	1		

# E K960 RING

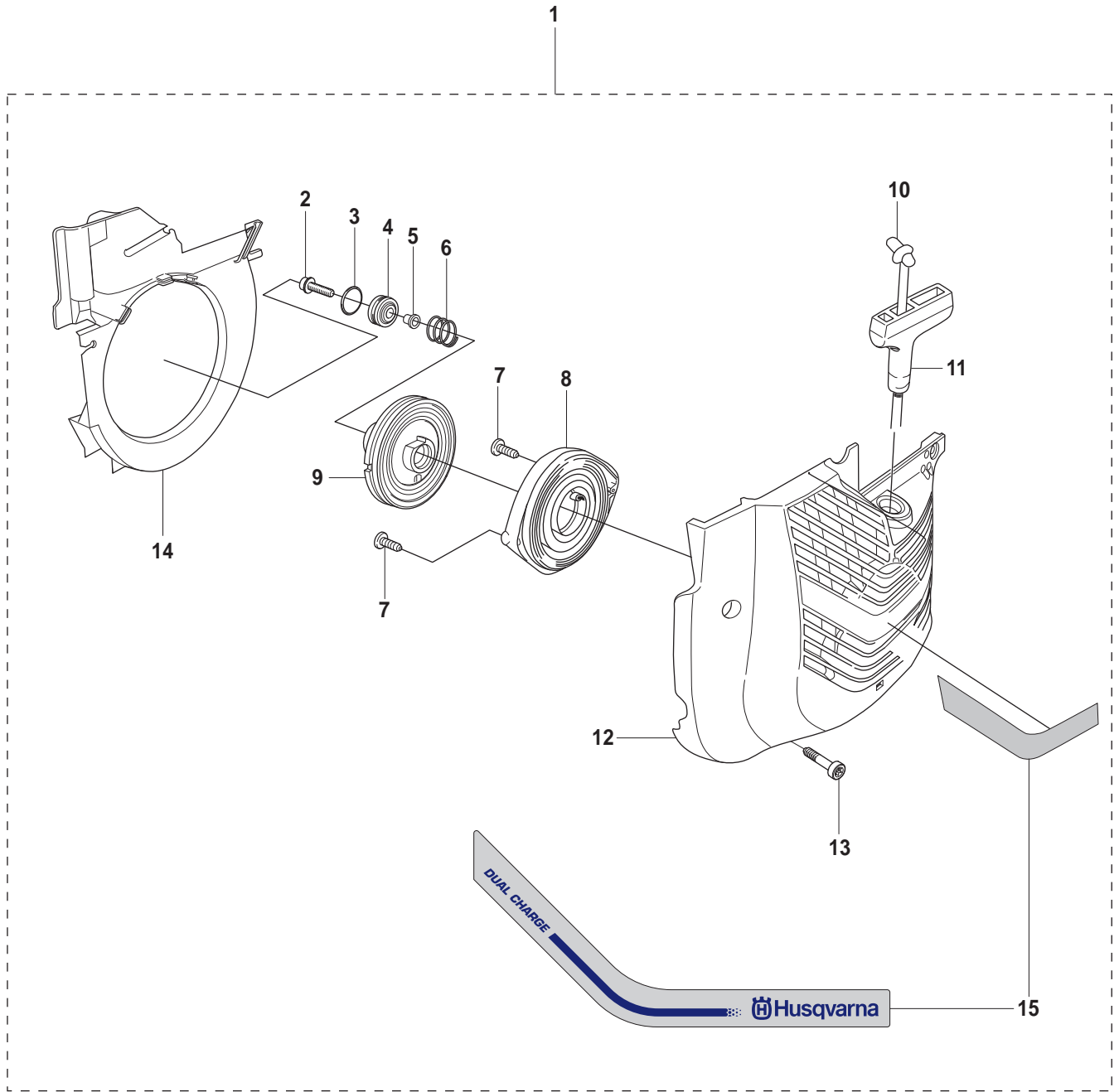

**Page E**  
**K960 Ring**

<b>Pos.</b>	<b>Part No.</b>	<b>Description</b>	<b>Quantity</b>	<b>Notes</b>	<b>New Part</b>
1	506 23 59-13	STARTER	1	Incl. 2 - 15	
2	503 21 07-22	SCREW	1		
3	740 43 13-00	O-RING	1		
4	506 25 14-01	GROMMET	1		
5	506 26 31-01	SPACING SLEEVE	1		
6	506 25 30-01	COMPRESSION SPRING	1		
7	503 21 28-10	SCREW	2		
8	506 25 89-01	RECOIL SPRING	1		
9	506 25 81-02	STARTER PULLEY	1		
10	506 33 56-15	STARTER CORD	1		
10	506 33 56-50	STARTER CORD	1	50 m Coil	
11	503 12 79-01	STARTER HANDLE	1		
12	506 21 84-04	STARTER COVER	1		
13	503 21 53-21	SCREW	4		
14	544 28 75-01	COOLING AIR CONDUCTOR	1		
15	506 27 23-03	LABEL	1		

# F K960 RING

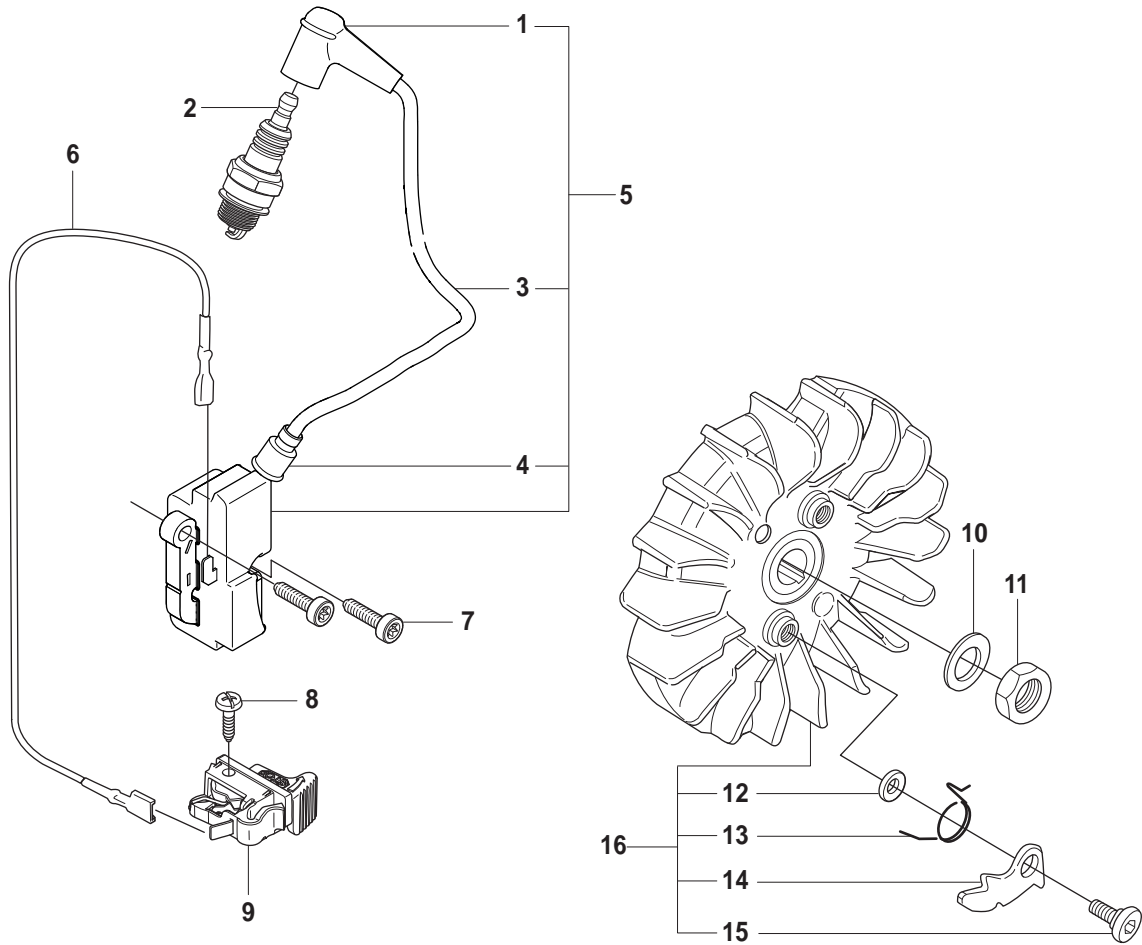

**Page F**  
**K960 Ring**

<b>Pos.</b>	<b>Part No.</b>	<b>Description</b>	<b>Quantity</b>	<b>Notes</b>	<b>New Part</b>
1	501 48 54-02	SPARK PLUG CAP	1		
2	503 23 51-09	SPARK PLUG	1	RCJ 6Y	
3	506 38 78-34	IGNITION CABLE	1		
4	505 27 75-16	ISOLERHATT	1		
5	544 04 75-03	IGNITION MODULE	1	Incl. 1, 3, 4	
6	501 83 98-01	CABLE	1		
7	503 21 53-20	SCREW	2		
8	503 21 28-06	SCREW	1		
9	506 31 86-02	STOP SWITCH	1		
10	503 23 01-01	WASHER STEEL	1		
11	503 22 10-11	NUT	1		
12	503 23 00-42	WASHER STEEL	2		
13	501 63 48-01	SPRING	2		
14	501 67 32-03	PAWL	2		
15	501 81 99-01	SCREW	2		
16	506 27 27-03	FLYWHEEL	1	Incl. 12 - 15	

**G** K960 RING

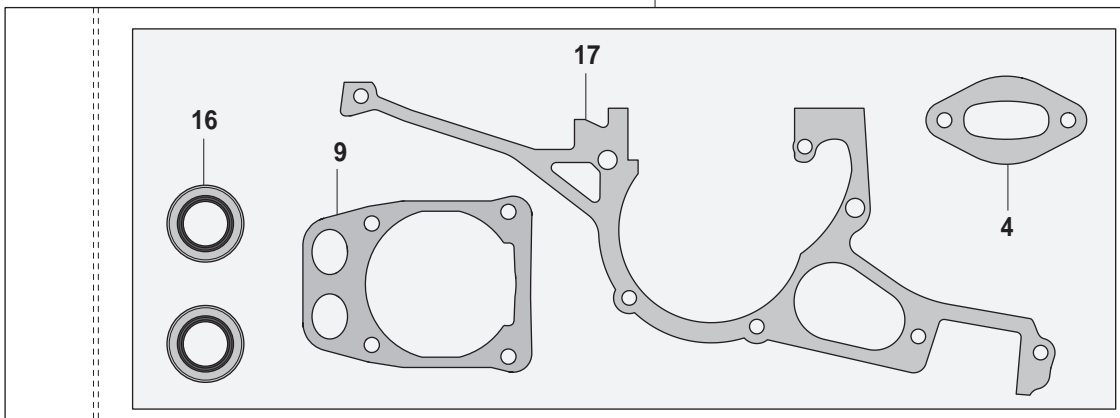
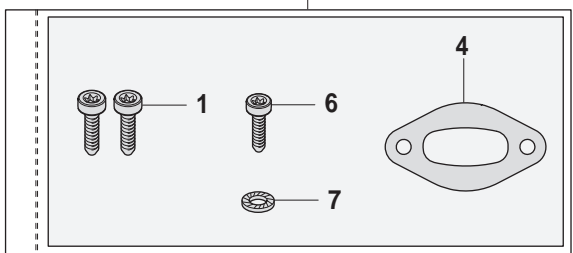
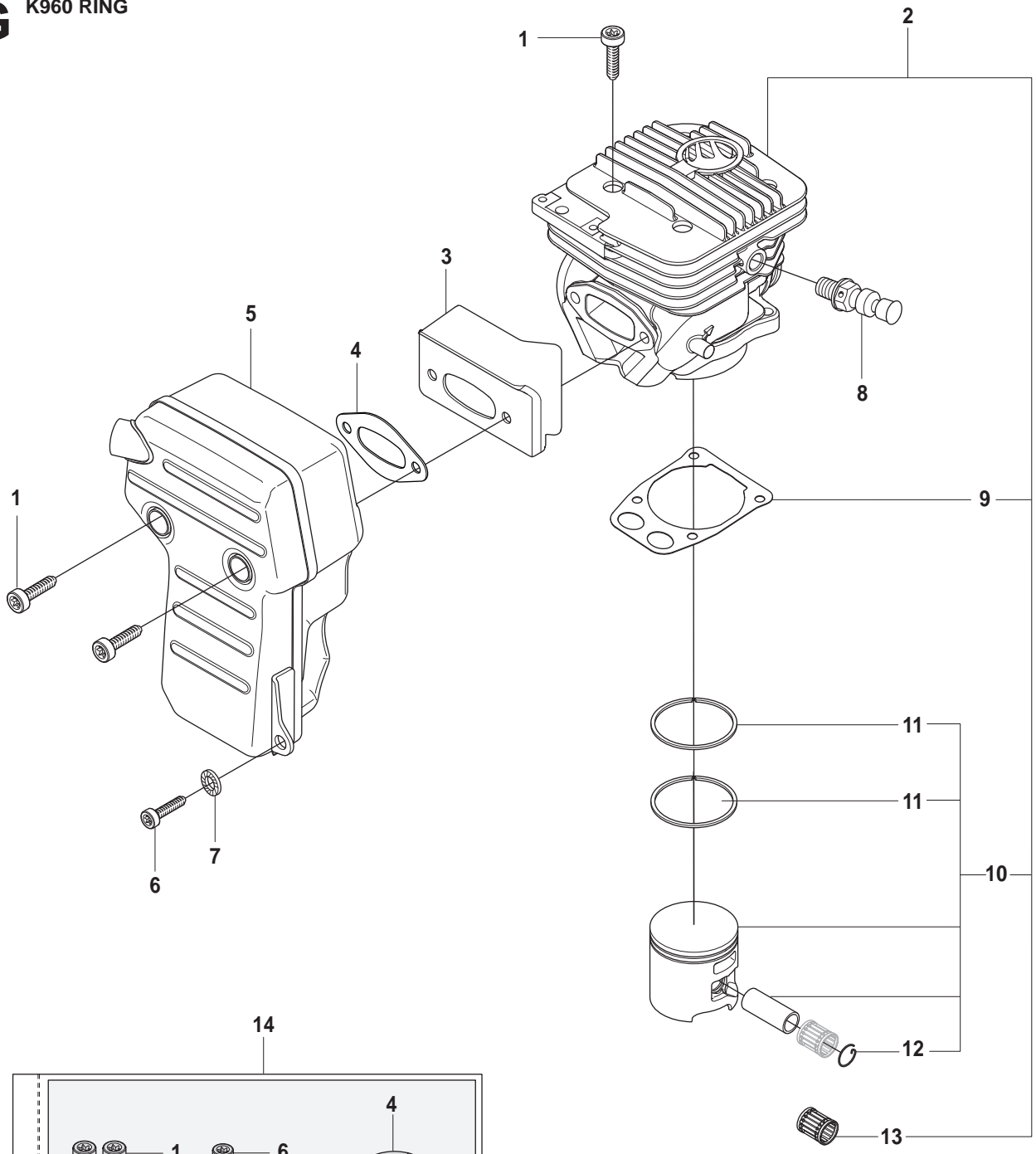

**Page G**  
**K960 Ring**

<b>Pos.</b>	<b>Part No.</b>	<b>Description</b>	<b>Quantity</b>	<b>Notes</b>	<b>New Part</b>
1	544 21 84-01	SCREW	6		
2	544 93 56-02	CYLINDER ASSY	1	Incl. 9, 10, 13	
3	544 21 52-01	HEAT DEFLECTOR	1		
4	506 37 81-01	GASKET MUFFLER	1		
5	506 37 28-01	MUFFLER	1		
6	503 21 53-25	SCREW	1		
7	503 23 04-02	WASHER	1		
8	503 66 56-01	DECOMPRESSION VALVE	1		
9	506 41 40-01	GASKET	1		
10	506 41 32-02	PISTON	1	Incl. 11, 12	
11	503 28 90-35	PISTON RING	2		
12	737 44 13-00	CIRCLIP	2		
13	503 25 61-01	NEEDLE BEARING	1		
14	505 25 96-03	MUFFLER MOUNT KIT	1	Incl. 1, 4, 6, 7	
15	544 22 98-02	GASKET KIT	1	Incl. 4, 9, 16, 17	
16	503 26 02-05	SEALING RING	2		
17	506 41 39-02	GASKET	1		

**H** K960 RING

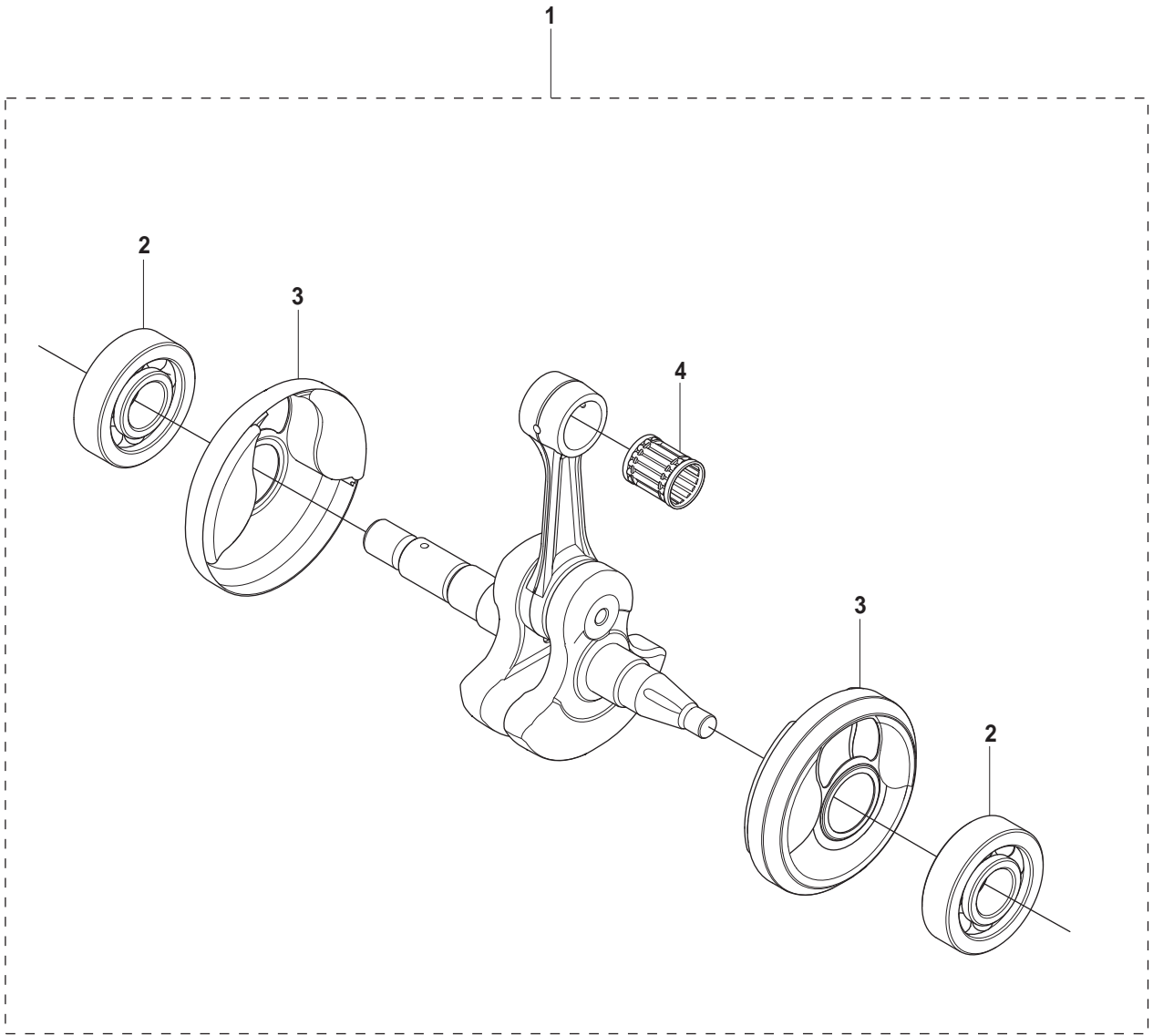



**Page H**  
**K960 Ring**

<b>Pos.</b>	<b>Part No.</b>	<b>Description</b>	<b>Quantity</b>	<b>Notes</b>	<b>New Part</b>
1	544 98 39-01	CRANKSHAFT ASSY	1	Incl. 2 - 4	
2	503 25 00-02	BALL BEARING	2		
3	506 41 44-01	CUP	2		
4	503 25 61-01	NEEDLE BEARING	1		

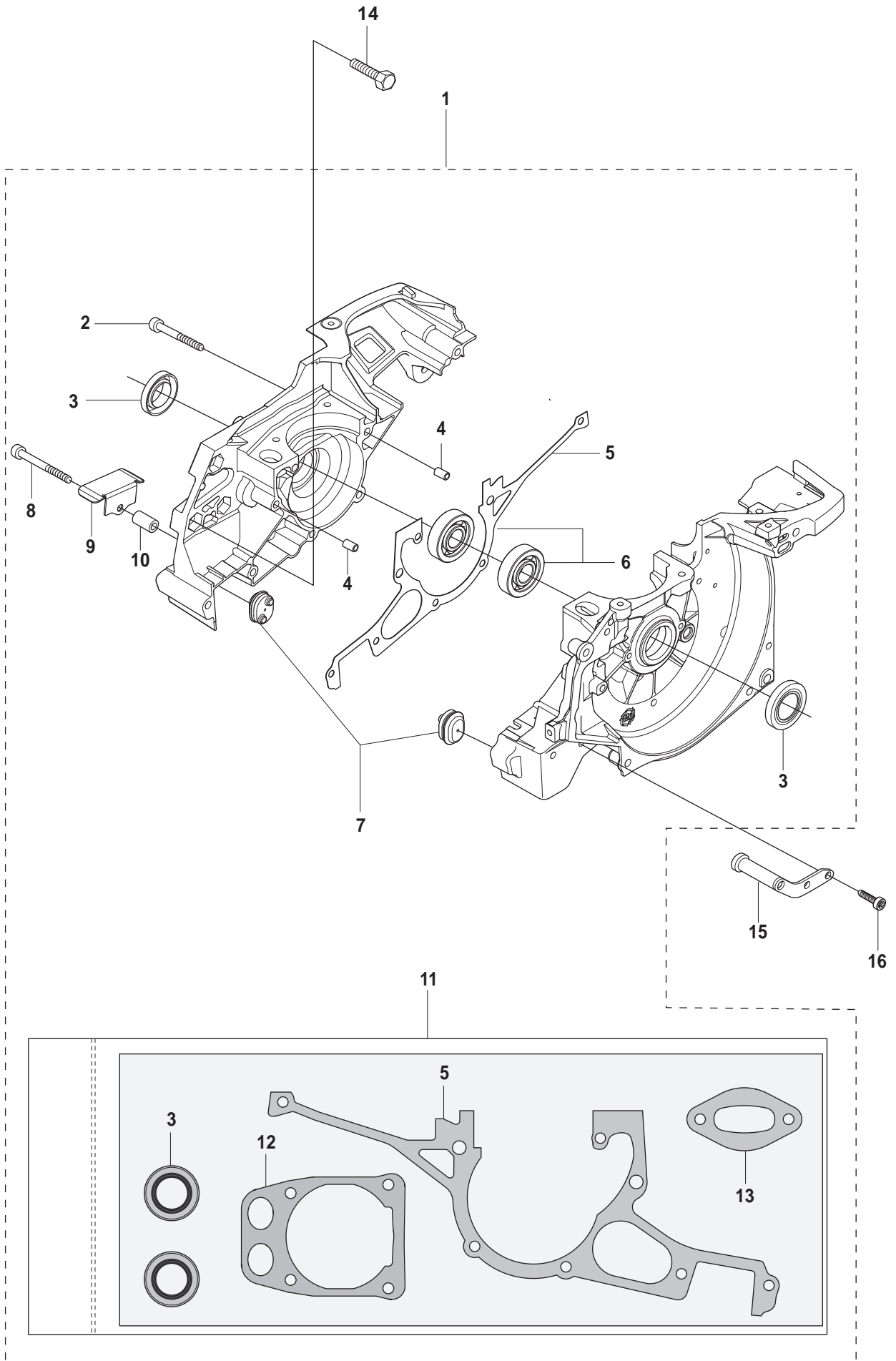
**J****K960 RING**

**Page J**  
**K960 Ring**

<b>Pos.</b>	<b>Part No.</b>	<b>Description</b>	<b>Quantity</b>	<b>Notes</b>	<b>New Part</b>
1	504 88 72-01	CRANKCASE ASSY	1	Incl. 2 - 8	
2	503 21 53-49	SCREW	6		
3	503 26 02-04	SEALING RING	2	Gasket kit 11	
4	501 27 08-01	GUIDE BUSHING	2		
5	506 41 39-02	GASKET	1	Gasket kit 11	
6	503 25 00-02	BALL BEARING	2		
7	544 89 54-01	RUBBER BUSHING	2		
8	503 21 53-56	SCREW	1		
9	544 09 64-01	BELT GUIDE	1		
10	544 09 77-01	BUSHING	1		
11	544 22 98-02	GASKET KIT	1	Incl. 3, 5, 12, 13	
12	506 41 40-01	GASKET	1		
13	506 37 81-01	GASKET MUFFLER	1		
14	506 03 32-02	SCREW	2		
15	506 34 91-01	BRACKET ASSY	1		
16	505 57 41-01	SCREW	2		

# K K960 RING

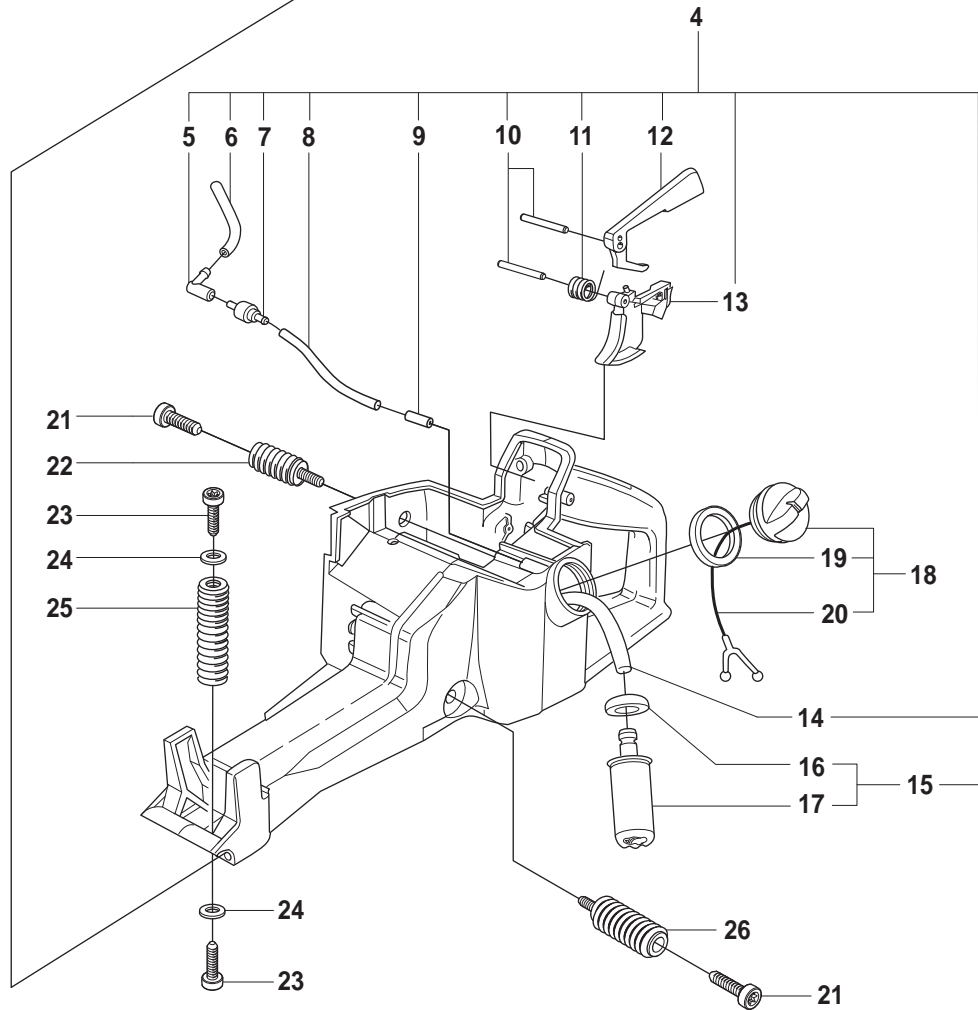
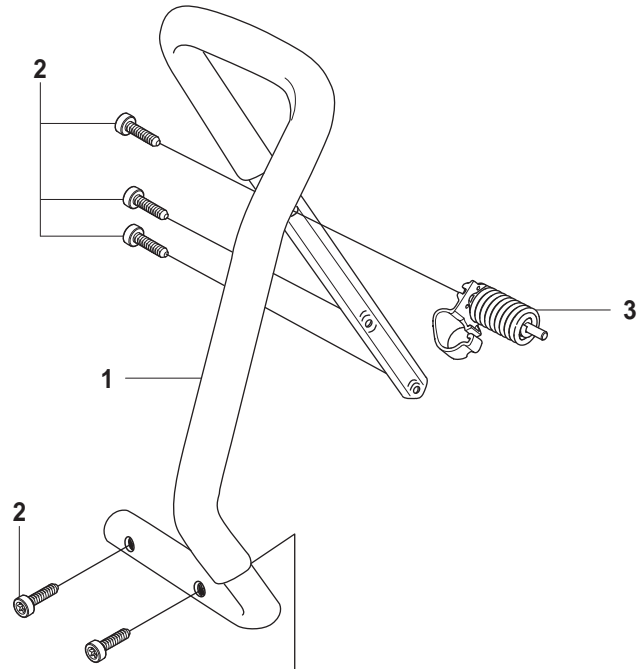

**Page K**  
**K960 Ring**

<b>Pos.</b>	<b>Part No.</b>	<b>Description</b>	<b>Quantity</b>	<b>Notes</b>	<b>New Part</b>
1	502 57 47-01	HANDLE	1		
2	503 21 54-20	SCREW	5		
3	506 38 91-03	ANTIVIBRATION ELEMENT	1		
4	544 89 20-06	FUEL TANK	1	Incl. 5 - 15	
5	503 45 46-01	CONNECTION BEND	1		
6	544 32 49-06	FUEL HOSE	1		
7	506 23 61-01	TANK VENT	1		
8	544 32 49-32	FUEL HOSE	1		
9	506 28 95-01	NIPPLE	1		
10	720 12 40-20	PARALLEL PIN	2		
11	506 22 29-01	SPRING THROTTLE TRIG	1		
12	506 22 28-02	THROTTLE LOCKOUT	1		
13	506 22 27-03	THROTTLE TRIGGER	1		
14	544 32 50-02	FUEL HOSE	1		
15	506 26 41-11	FUEL FILTER	1	Incl. 16, 17	
16	506 27 11-01	HOSE CLAMP	1		
17	506 26 41-01	FUEL FILTER	1		
18	506 25 59-03	TANK CAP ASSY	1	Incl. 19, 20	
19	506 29 21-01	GASKET	1		
20	503 57 89-01	HOLDER	1		
21	544 06 12-01	SCREW	1		
22	537 21 03-09	ANTIVIBRATION ELEMENT	1		
23	503 21 53-16	SCREW	2		
24	503 23 00-11	WASHER STEEL	2		
25	503 46 85-01	ANTIVIBRATION ELEMENT	1		
26	544 38 31-02	SPRING	1		



K960 RING

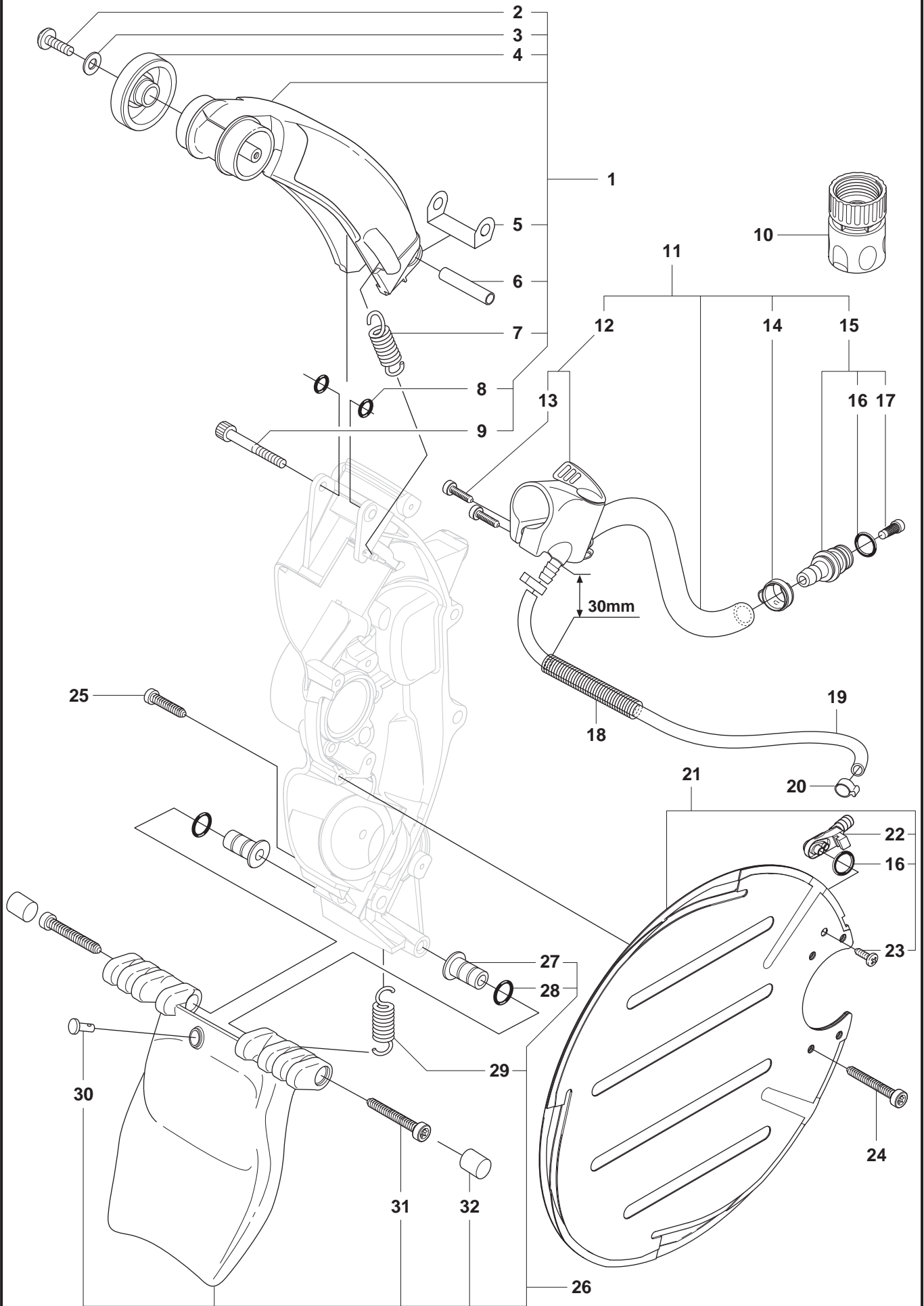

**Page L**  
**K960 Ring**

Pos.	Part No.	Description	Quantity	Notes	New Part
1	506 24 69-06	BLADE GUARD	1	Incl. 2 - 9	
2	503 21 46-01	SCREW	2		
3	734 48 80-01	WASHER	2		
4	506 26 22-02	WHEEL	2		
5	506 31 28-01	COVER PLATE	1		
6	506 31 45-01	SPACER TUBE	1		
7	504 11 67-01	SPRING	1		
8	503 26 30-25	O-RING	2		
9	544 21 84-47	SCREW	1		
10	503 26 60-03	COUPLER	1		
11	506 38 59-04	HOSE ASSY	1	Incl. 12, 14 - 15	
12	506 38 60-12	VALVE ASSY	1	Incl 13	
13	503 21 54-20	SCREW	2		
14	506 09 56-06	HOSE CLAMP	2		
15	506 29 57-02	NIPPLE	1	Incl. 16, 17	
16	503 26 30-21	O-RING	2		
17	506 29 88-01	FILTER	1		
18	506 35 27-01	PROTECTIVE SPRING	1		
19	506 09 58-12	HOSE	1	210 mm	
20	506 09 56-03	HOSE CLAMP	2		
21	506 38 33-01	WATER BLADE	1	Incl. 16, 22, 23	
22	506 38 29-01	NIPPLE	1		
23	729 52 89-71	SCREW	1		
24	505 57 41-01	SCREW	4		
25	503 21 53-20	SCREW	1		
26	506 35 22-05	SPRAY GUARD ASSY	1	Incl. 27 - 32	
27	506 33 49-02	SPACER TUBE	2		
28	740 42 05-00	O-RING	2		
29	506 33 95-01	DRAW SPRING	1		
30	506 33 96-01	BOLT	1		
31	544 21 84-37	SCREW	2		
32	506 34 90-01	SEALING	2		

**M** K960 RING

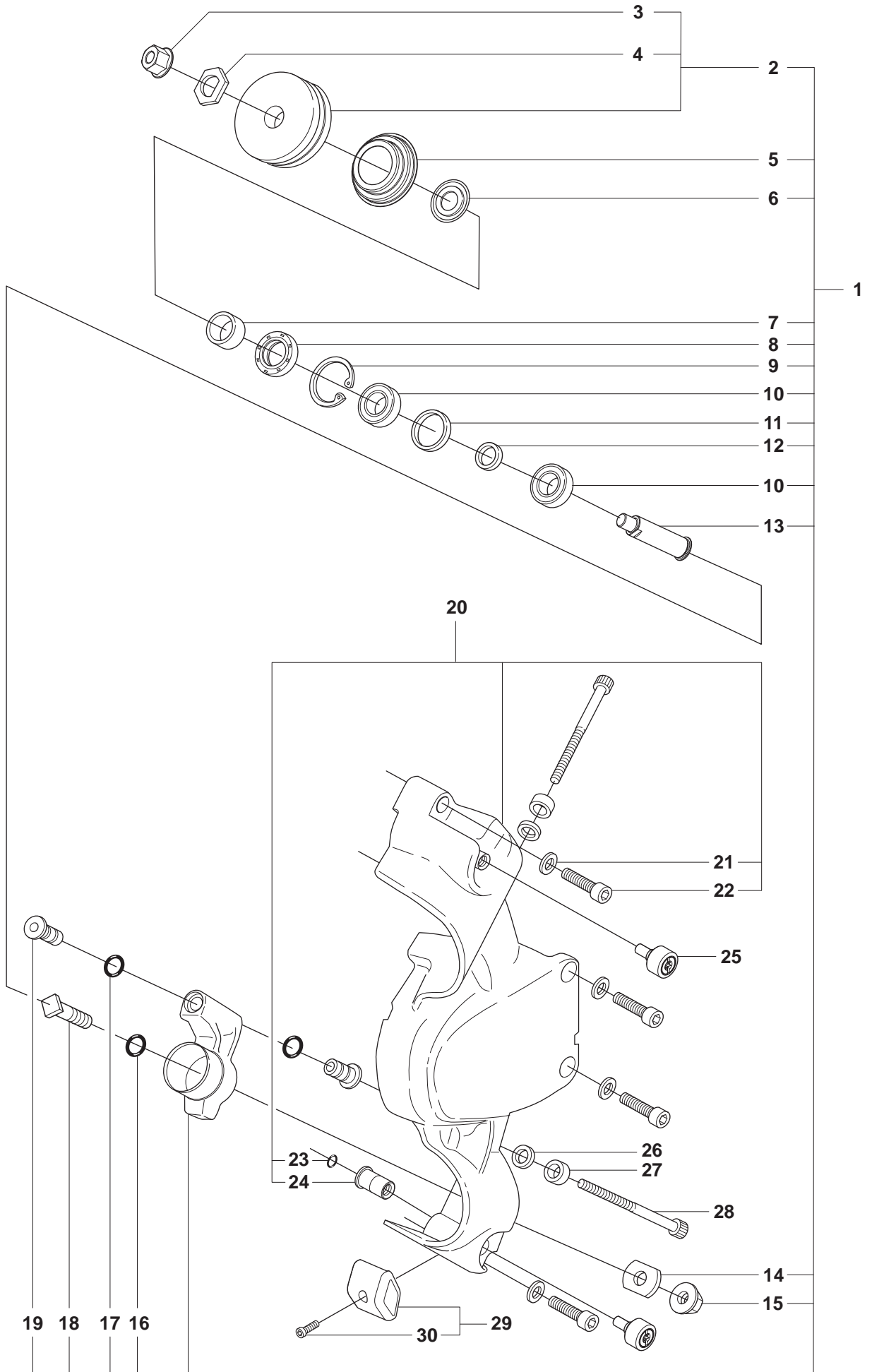



**Page M**  
**K960 Ring**

Pos.	Part No.	Description	Quantity	Notes	New Part
1	506 35 18-07	LEVER ASSY	2	Incl. 2, 5 - 18	
2	506 35 21-03	SUPPORT ROLLER	1	Incl. 3, 4	
3	503 22 04-01	NUT FLANGE	1	Fine thread	
4	506 30 34-01	DRIVER	1		
5	506 39 95-01	SEALING	1		
6	506 32 17-01	WASHER	1		
7	506 37 93-02	SPACING SLEEVE	1		
8	503 26 20-01	SEALING RING	1		
9	735 31 28-10	CIRCLIP	1		
10	503 25 24-01	BALL BEARING	2		
11	506 31 68-02	SPACING SLEEVE	1		
12	506 30 33-02	SPACING SLEEVE	1		
13	506 49 32-02	SHAFT	1		
14	506 34 63-01	WASHER	1		
15	503 22 00-01	NUT	1		
16	503 26 30-08	O-RING	1		
17	503 26 30-26	O-RING	2		
18	506 34 64-01	SCREW	1		
19	506 33 49-03	SPACER TUBE	2		
20	506 28 03-05	COVER	1	Incl. 21 - 24	
21	503 23 04-03	WASHER	4		
22	503 20 54-35	SCREW	4		
23	740 42 04-00	O-RING	2		
24	506 33 08-01	THREAD BUSHING	2		
25	505 57 49-01	ADJUSTING SCREW	2		
26	506 37 63-01	SPACER	2		
27	506 37 64-01	RUBBER BUSHING	2		
28	725 53 81-56	SCREW	2		
29	506 35 19-03	WEAR PROTECTION	1	Incl. 29	
30	505 57 41-01	SCREW	1		

# N K960 RING

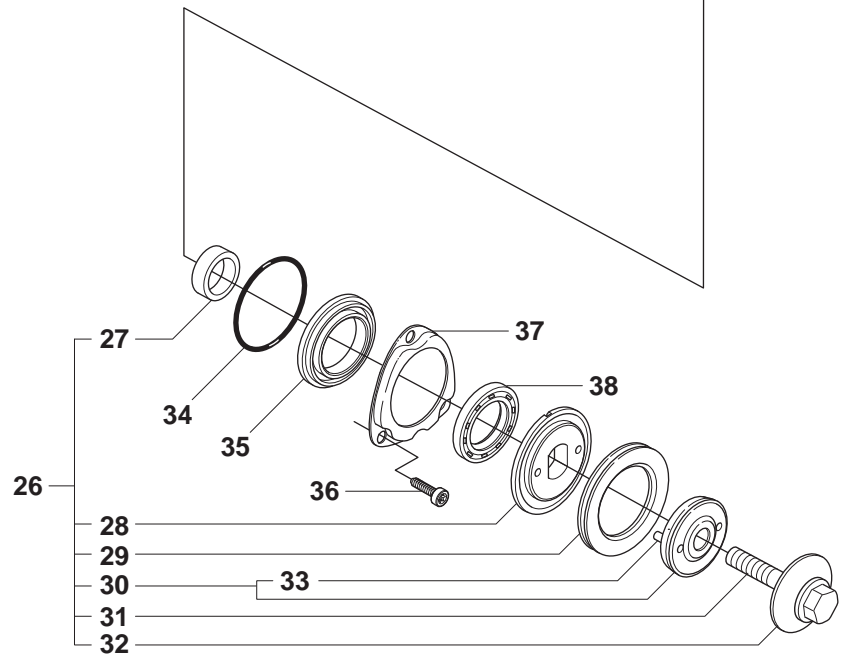
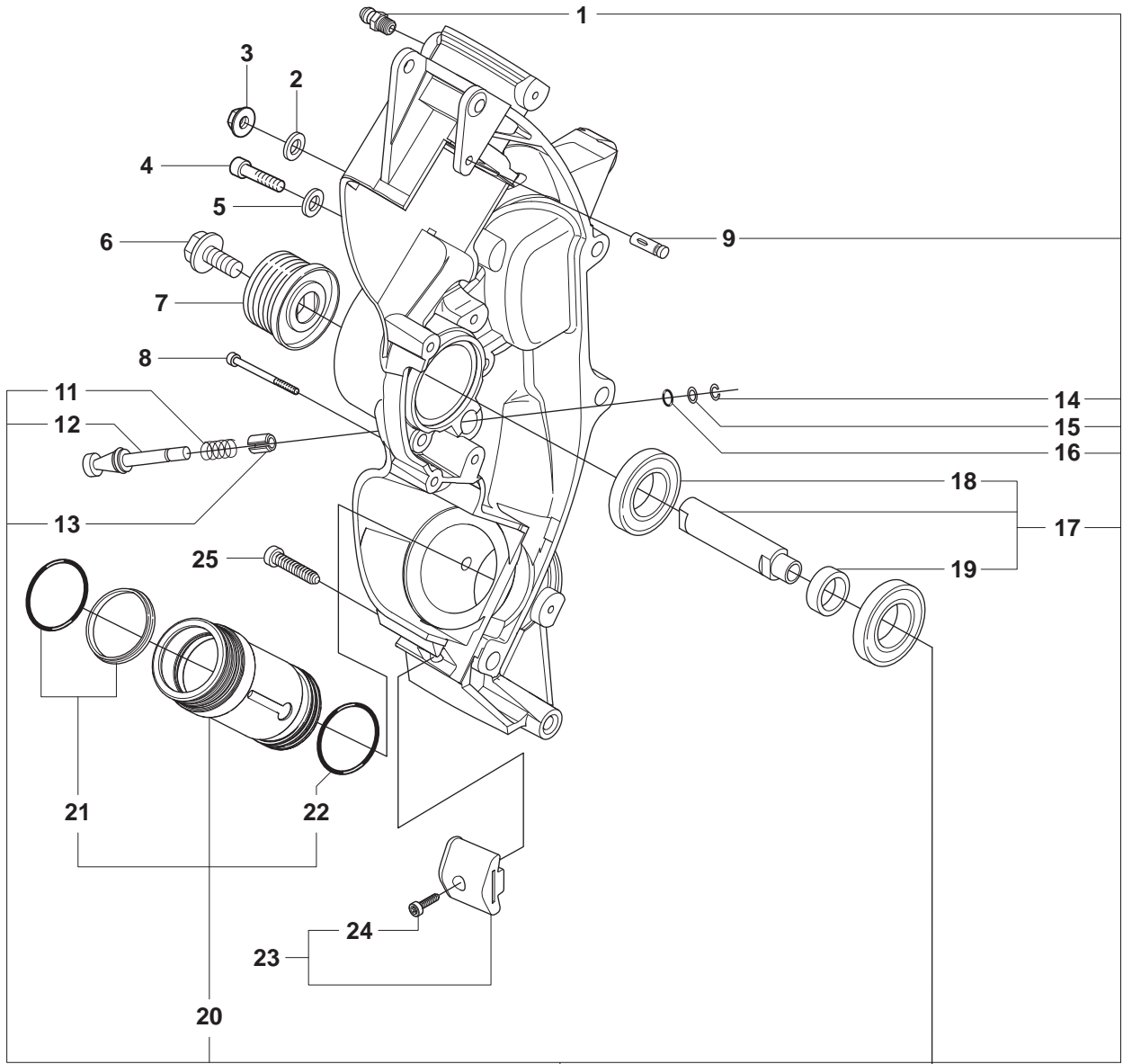

**Page N**  
**K960 Ring**

Pos.	Part No.	Description	Quantity	Notes	New Part
1	738 88 10-01	LUBRICATION NIPPLE	2		
2	503 22 00-01	NUT FLANGE	2		
3	503 23 04-01	WASHER	2		
4	725 54 59-05	SCREW	1		
5	503 23 04-03	WASHER	1		
6	503 20 00-45	SCREW	1		
7	506 27 75-01	PULLEY	1		
8	501 98 10-80	SCREW	1		
9	721 12 52-70	PIN	1		
10	506 38 90-07	CHASSIS	1	Incl. 1, 9, 11 - 17, 20	
11	506 25 73-01	COMPRESSION SPRING	1		
12	506 32 80-01	LOCKING BUTTON	1		
13	721 44 06-00	PIN	1		
14	735 31 08-00	CIRCLIP	1		
15	503 23 01-12	WASHER STEEL	1		
16	503 26 30-22	O-RING	1		
17	506 35 15-02	DRIVE SHAFT	1	Incl. 18 - 19	
18	503 25 21-01	BALL BEARING	2		
19	506 37 50-02	SPACER	1		
20	544 07 76-01	SLEEVE	2	Incl. 21 - 22	
21	506 34 39-01	WIPER	2		
22	740 48 25-02	O-RING	2		
23	506 35 19-03	WEAR PROTECTION	1	Incl. 24	
24	505 57 41-01	SCREW	1		
25	503 21 53-20	SCREW	1		
26	506 35 23-04	GEAR WHEEL ASSY	1	Incl. 27 - 32	
27	506 37 49-01	SLEEVE	1		
28	506 37 46-02	FLANGE WASHER	1		
29	506 17 83-04	GEAR WHEEL	1		
30	506 31 22-02	DRIVER	1	Incl. 33	
31	506 13 96-01	COLLAR SCREW	1		
32	506 13 95-11	WASHER	1		
33	721 42 52-50	SPRING PIN	2		
34	740 42 24-00	O-RING	1		
35	506 37 48-01	SEALING HOLDER	1		
36	503 21 53-12	SCREW	3		
37	506 37 47-01	SEALING COLLAR	1		
38	503 26 21-01	SEALING RING	1		

**P** K960 RING

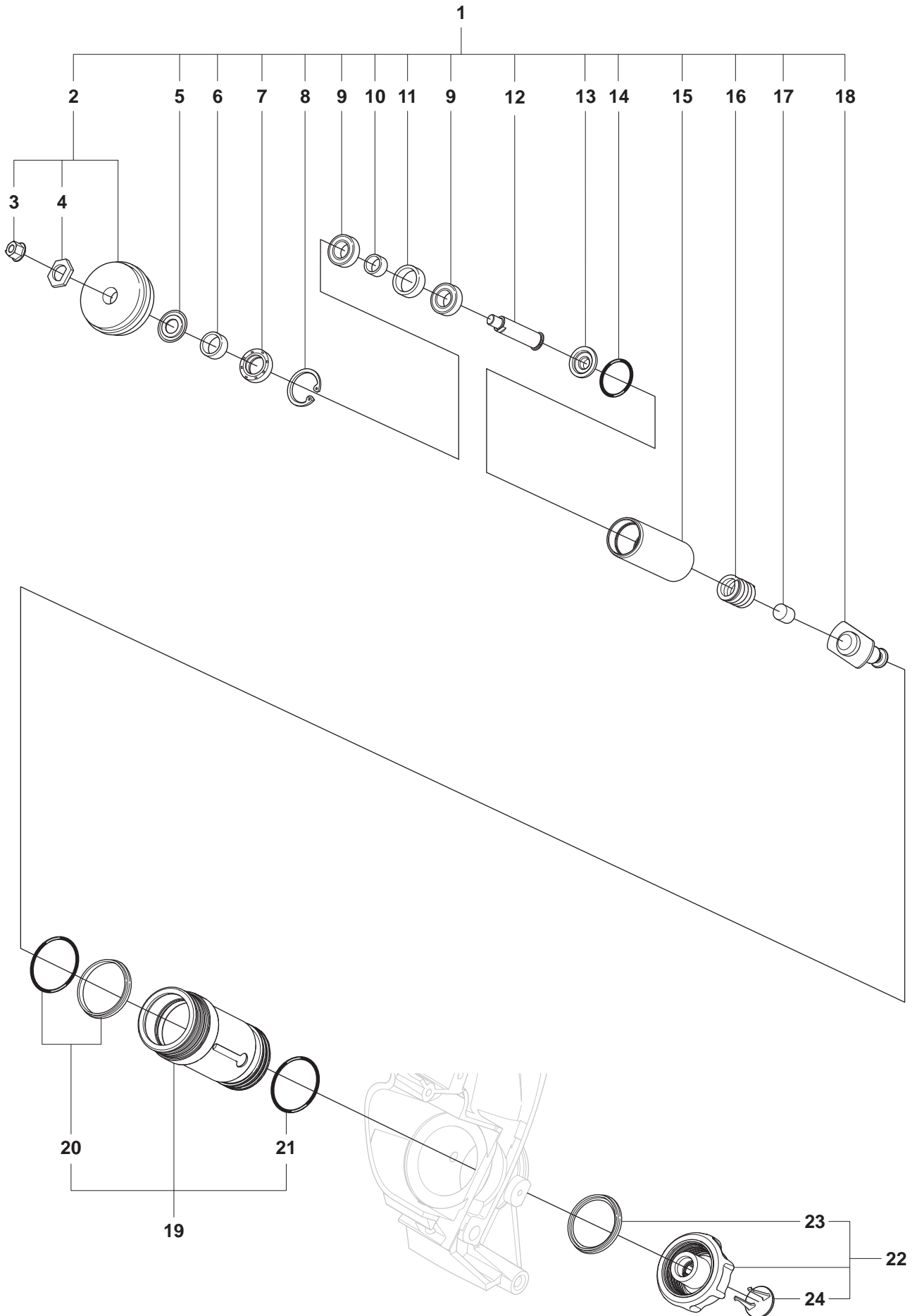

**Page P**  
**K960 Ring**

Pos.	Part No.	Description	Quantity	Notes	New Part
1	506 49 34-01	BEARING CAGE	2	Incl. 2, 5 - 18	
1	506 49 34-02	BEARING CAGE	2	Incl. 2, 5 - 18. Sweden only	
2	506 35 20-05	GUIDE ROLLER	1	Incl. 3, 4	
2	506 35 20-06	GUIDE ROLLER	1	Incl. 3, 4. Sweden only	
3	503 22 04-01	NUT	1		
4	506 30 34-01	DRIVER	1		
5	506 31 69-01	DUST COVER	1		
6	506 37 93-02	SPACING SLEEVE	1		
7	503 26 20-01	SEALING RING	1		
8	735 31 28-10	CIRCLIP	1		
9	503 25 24-01	BALL BEARING	2		
10	506 30 33-01	SPACING SLEEVE	1		
11	506 31 68-01	SPACING SLEEVE	1		
12	506 49 32-01	SHAFT	1		
13	506 38 11-01	CAP	1		
14	740 48 20-12	RING	1		
15	506 38 09-01	BEARING CAGE	1		
16	506 34 76-01	COMPRESSION SPRING	1		
17	506 30 35-01	BUMPER	1		
18	506 38 97-01	PIN	1		
19	544 07 76-01	SLEEVE	2	Incl. 20, 21	
20	506 34 39-01	WIPER	1		
21	740 48 25-02	O-RING	1		
22	506 38 22-02	KNOB	1	Incl. 23	
23	506 33 65-01	SEALING RING	1		
24	506 38 21-02	CAP	1		

**Q** K960 RING

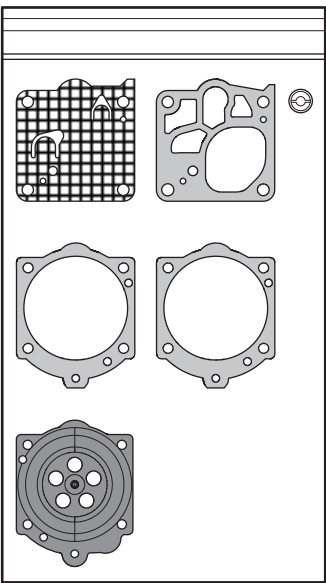
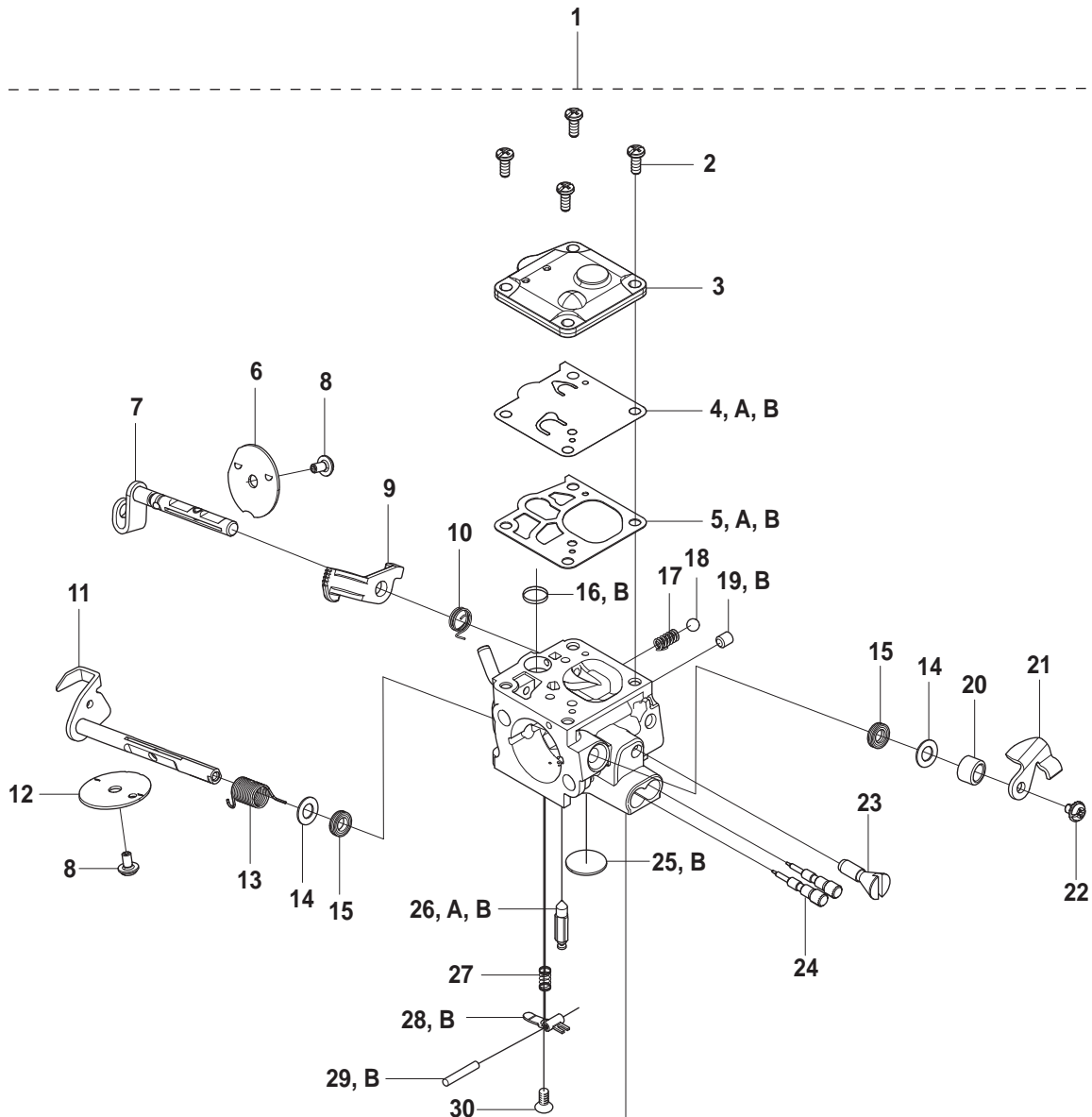

36, A

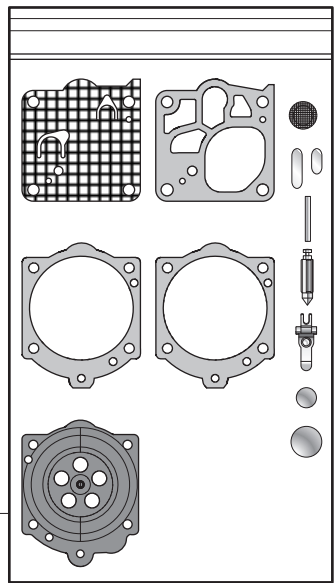

37, B

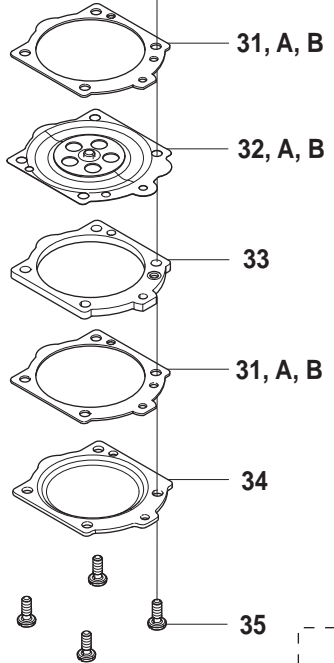

**Page Q**  
**K960 Ring**

Pos.	Part No.	Description	Quantity	Notes	New Part
1	502 62 32-01	CARBURETTOR ASSY	1	Incl. 2 - 32, Walbro RWJ-3	
2	503 11 75-01	SCREW	4		
3	544 89 62-01	PUMP COVER	1		
4	544 89 72-01	DIAPHRAGM PUMP	1	A, B	
5	503 11 72-01	GASKET PUMP	1	A, B	
6	504 13 52-01	VALVE	1		
7	504 83 51-01	SHAFT	1		
8	544 11 15-01	SCREW	2		
9	504 83 31-01	LEVER	1		
10	504 83 54-01	SPRING	1		
11	504 83 50-01	SHAFT	1		
12	504 13 53-01	VALVE	1		
13	544 95 68-01	SPRING	1		
14	505 31 67-48	WASHER	2		
15	503 56 45-01	SEAL	2		
16	501 66 61-01	SCREEN-INLET	1	B	
17	503 11 77-01	SPRING	1		
18	503 11 71-01	BALL-CHOKE FRICTION	1		
19	530 03 51-57	PLUG	1	B	
20	537 00 26-01	SPACER	1		
21	544 89 60-01	LEVER	1		
22	501 46 87-01	SCREW	1		
23	544 89 76-01	SCREW	1		
24	504 13 58-01	NEEDLE	2		
25	503 57 41-01	PLUG-WELCH	1	B	
26	503 63 25-01	VALVE -INLET NEEDLE	1	A, B	
27	503 11 76-01	SPRING	1		
28	505 31 67-34	LEVER	1	B	
29	505 31 67-31	PIN-METERING LEVER	1	B	
30	505 31 67-17	SCREW	1		
31	544 89 71-01	GASKET	2	A, B	
32	544 89 74-01	DIAPHRAGM ASSY	1	A, B	
33	544 89 79-01	PLATE	1		
34	544 89 63-01	COVER	1		
35	537 00 20-01	SCREW	4		
36	502 44 58-01	GASKET KIT	1	Kit A. D10-RWJ	
37	502 44 59-01	REPAIR KIT	1	Kit B. K10-RWJ	

**R** K950 RING  
Accessories  
Zubehöre  
Accessoires  
Accesorios  
Tillbehör

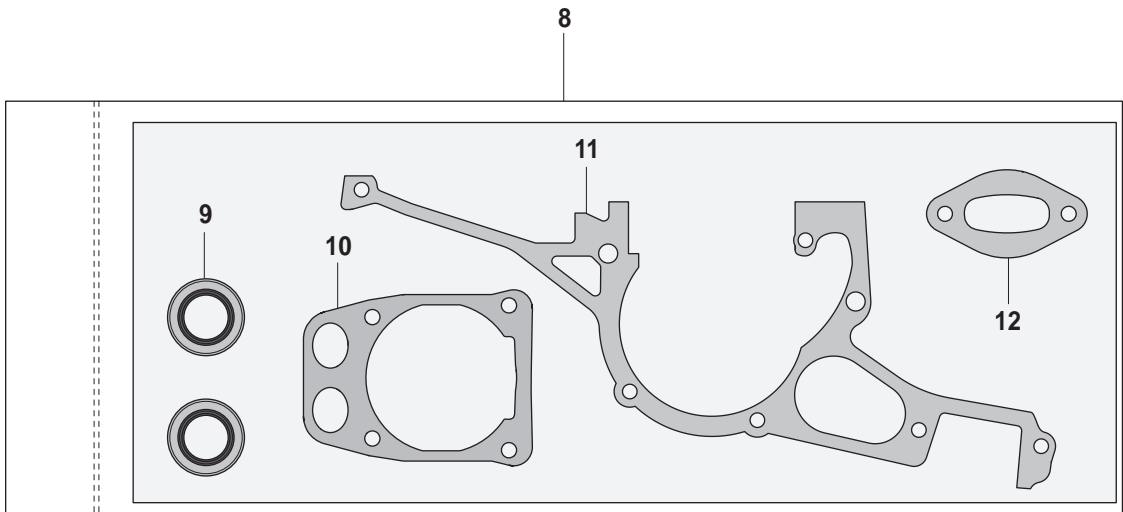
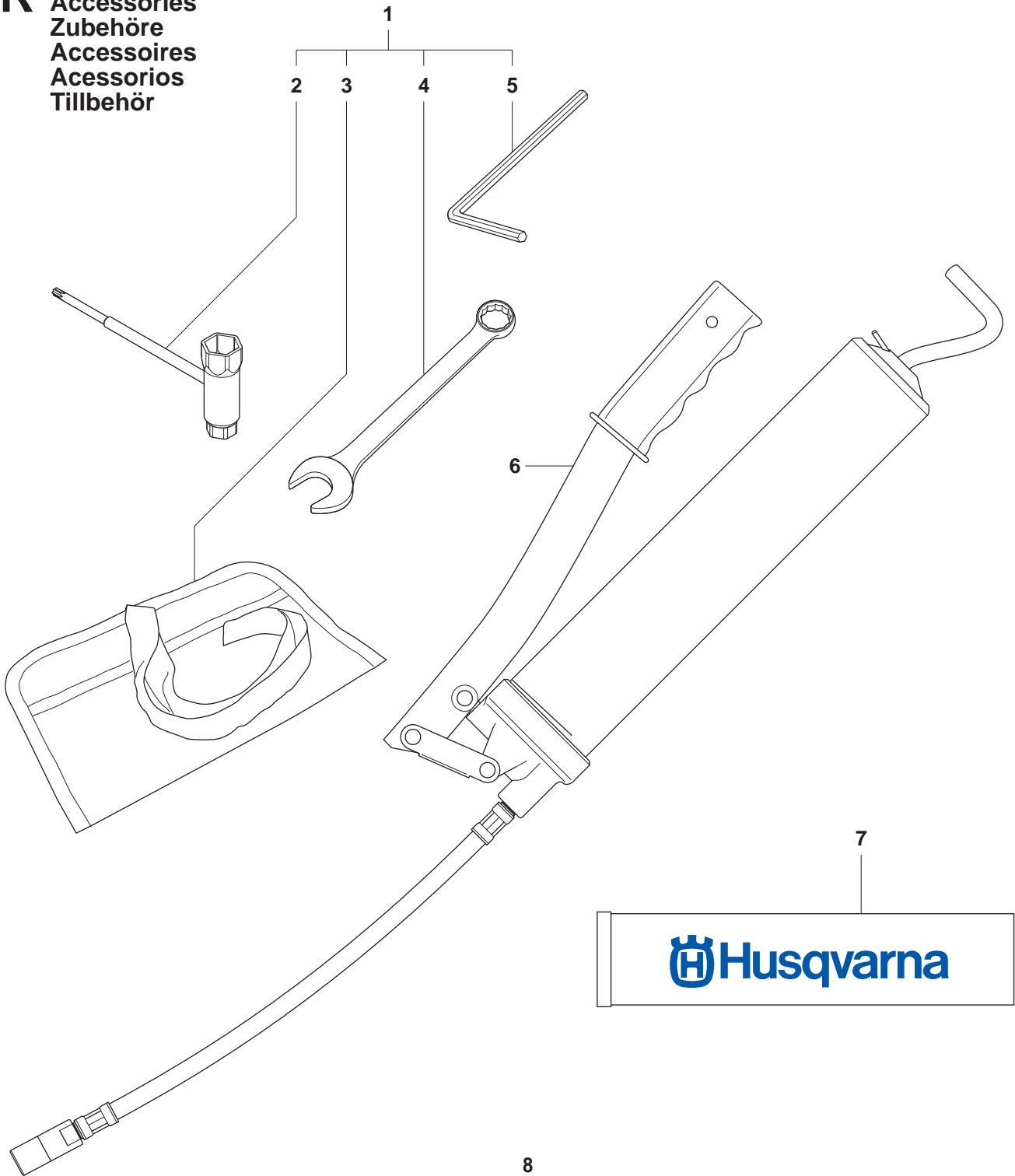



**Page R**  
**K960 Ring**

<b>Pos.</b>	<b>Part No.</b>	<b>Description</b>	<b>Quantity</b>	<b>Notes</b>	<b>New Part</b>
1	506 36 38-03	TOOL KIT	1	Incl. 2 - 5	
2	506 38 26-01	COMBINATION TOOL	1		
3	501 19 22-01	TOOL CASING	1		
4	506 35 52-01	TOOL	1	19mm	
5	506 36 36-01	L-SPANNER	1	Allenkey 6mm	
6	506 38 49-02	LUBRICATION GUN	1		
7	544 08 04-02	GREASE	1		
8	544 22 98-02	GASKET KIT	1	Incl. 9 - 12	
9	503 26 02-04	SEALING RING	2		
10	506 41 40-01	GASKET	1		
11	506 41 39-02	GASKET	1		
12	506 37 81-01	GASKET MUFFLER	1		

S

K960 RING

1

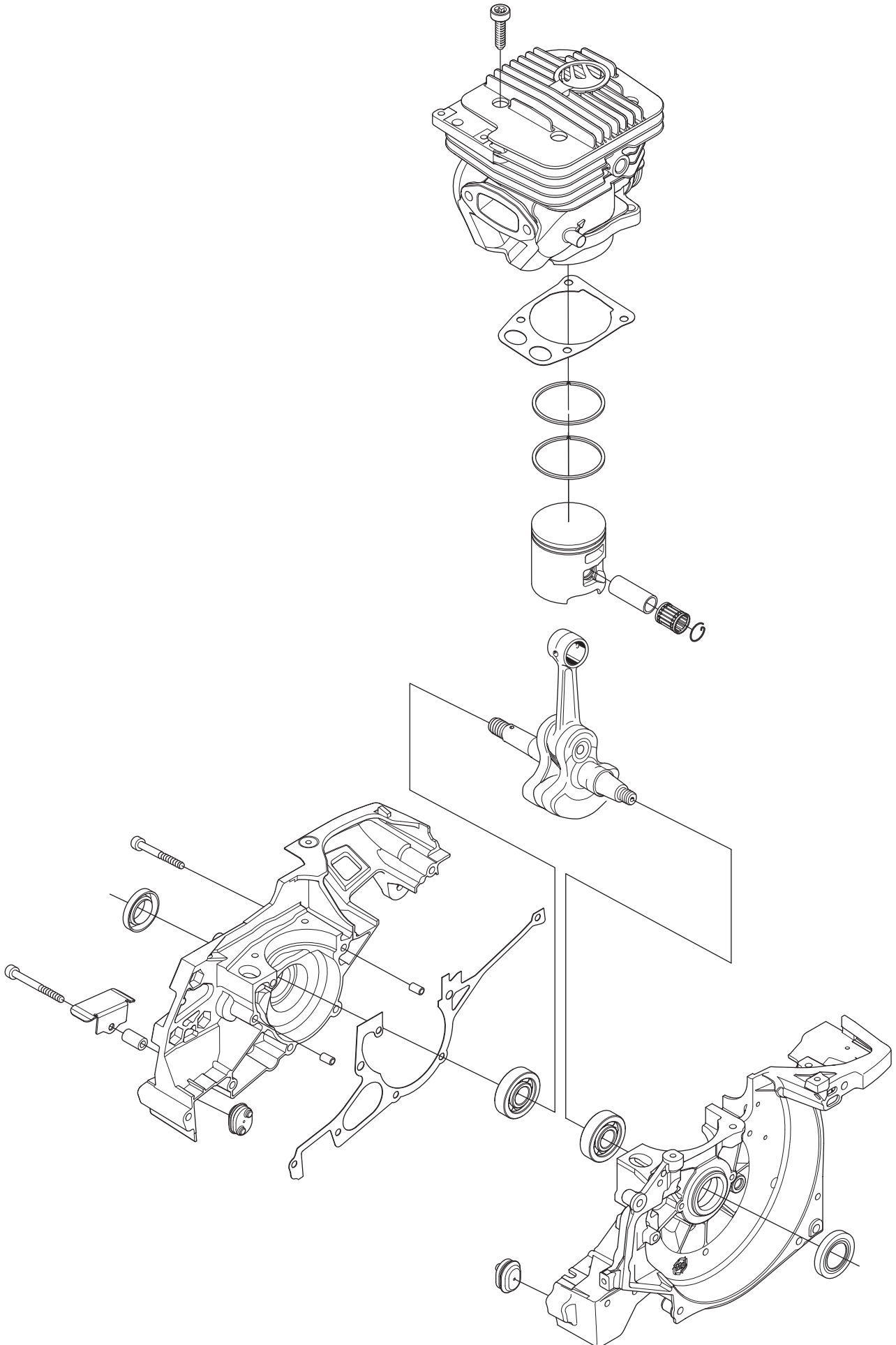

**Page S**  
**K960 Ring**

<b>Pos.</b>	<b>Part No.</b>	<b>Description</b>	<b>Quantity</b>	<b>Notes</b>	<b>New Part</b>
1	504 88 72-02	ENGINE KIT	1		