

K750

Reservdelar

Spare parts

Ersatzteile

Pieces de rechange

Piezas de repuesto

Ricambi

Peças sobresselente

A K750

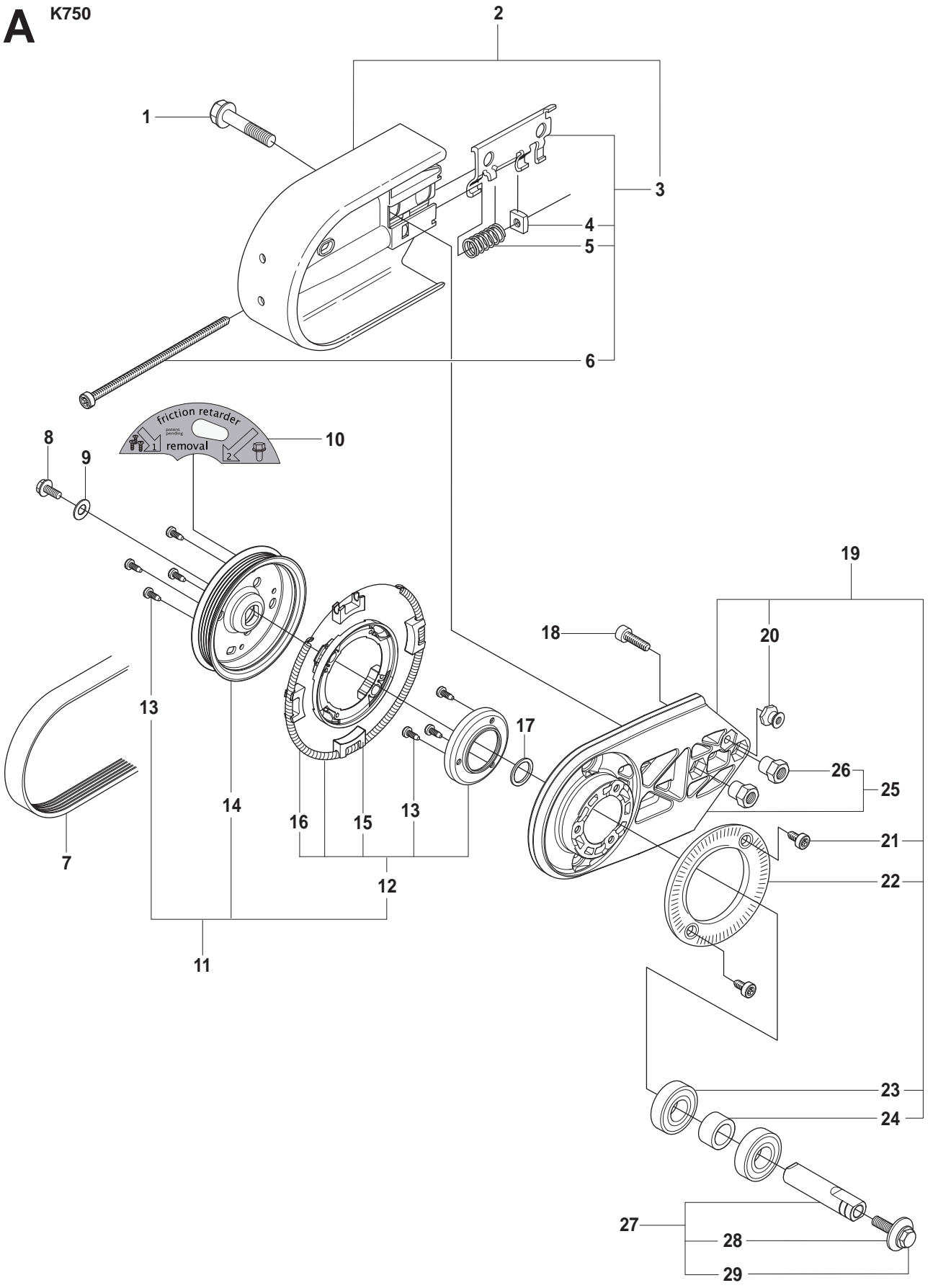

Page A
K750

Pos.	Part No.	Description	Quantity	Notes
1	506 28 44-02	COLLAR SCREW	2	
2	506 39 36-02	BELT GUARD	1	Incl. 3
3	506 26 66-04	BELT TENSIONER ASSY	1	Incl. 4 - 6
4	506 40 93-01	NUT	1	
5	506 26 68-01	COMPRESSION SPRING	1	
6	503 20 72-05	SCREW	1	
7	544 90 84-02	BELT	1	
8	503 20 00-45	SCREW	1	
9	503 23 01-16	WASHER STEEL	1	
10	502 47 04-01	LABLE	1	
11	504 03 70-01	PULLEY WITH RETARDER	1	Incl. 12 - 16
12	504 03 70-03	RETARDER CPL	1	Incl. 13, 15, 16
13	503 21 28-10	SCREW	7	
14	544 44 06-01	PULLEY	1	
15	544 44 04-01	BRAKE SHOE	4	
16	544 44 10-01	SPRING	1	
17	503 23 01-04	WASHER STEEL	1	
18	725 53 29-55	SCREW	1	
19	506 39 42-03	BEARING HOUSING	1	Incl. 20 - 24
20	506 14 32-01	TORSION STOP	1	
21	503 21 53-10	SCREW	2	
22	506 28 84-01	RATCHET FLANGE	1	
23	503 25 21-01	BALL BEARING	2	
24	506 07 08-01	SPACING SLEEVE	1	
25	506 39 42-11	BEARING HOUSING	1	Incl. 26
26	506 28 73-01	NUT	2	
27	506 29 83-63	SHAFT	1	Incl. 28, 29
28	506 13 95-11	WASHER	1	
29	506 13 96-01	COLLAR SCREW	1	

B K750

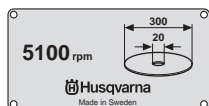
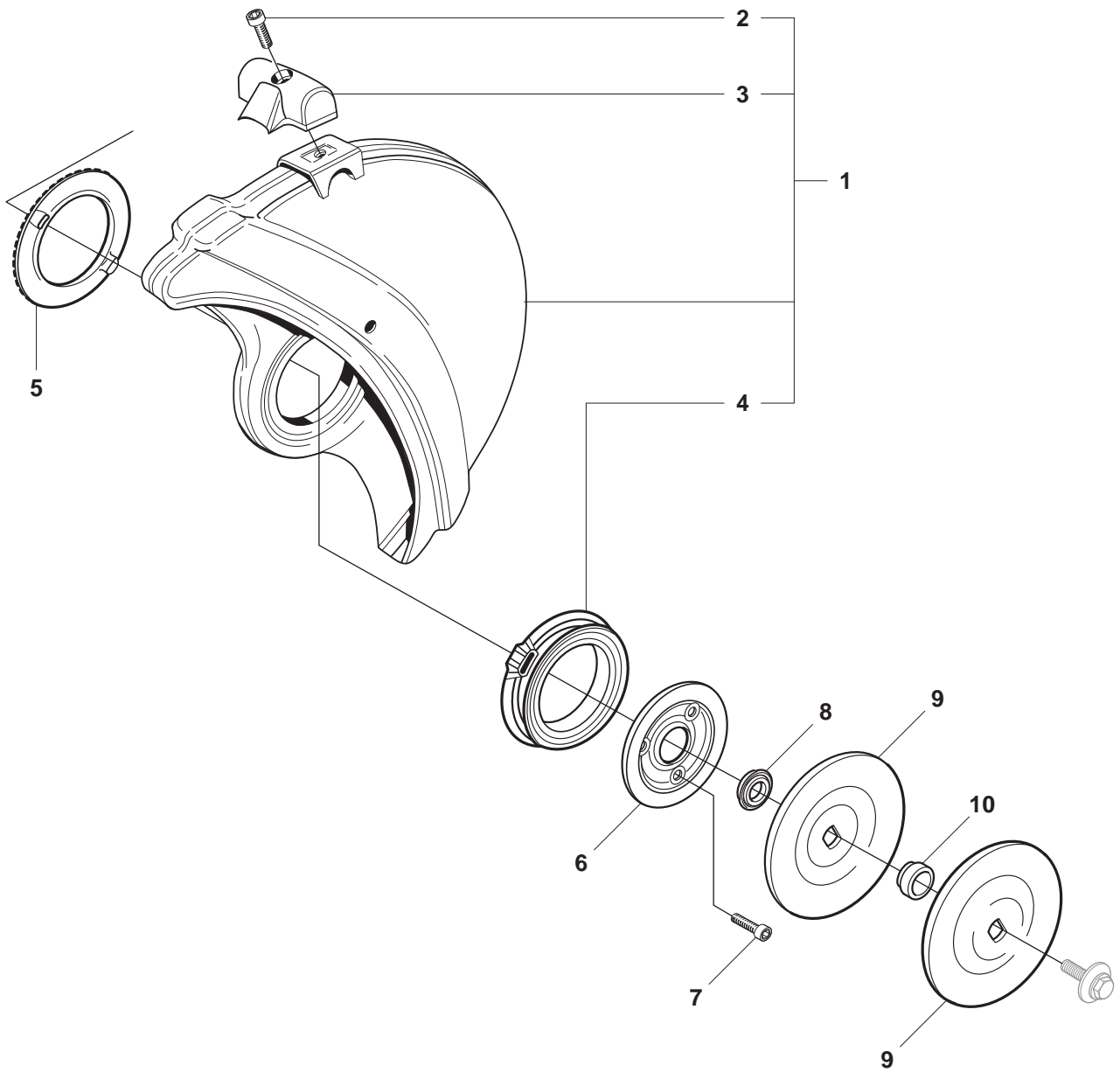

11

Page B
K750

Pos.	Part No.	Description	Quantity	Notes
1	506 34 05-02	WHEEL GUARD ASSY	1	12", Incl. 2 - 4
1	506 34 05-04	WHEEL GUARD ASSY	1	14", Incl. 2 - 4
2	725 53 31-05	SCREW	1	
3	506 34 46-02	HANDLE	1	
4	506 26 63-02	LINING	1	
5	506 26 64-01	SCREEN PATTERN FLANG	1	
6	506 26 65-01	FLANGE	1	
7	725 53 29-55	SCREW	1	
8	506 32 48-01	SUPPORT FLANGE	1	
9	506 02 87-01	FLANGE WASHER	2	Diam 105 mm
9	506 07 09-01	FLANGE WASHER	2	Diam 119 mm
10	506 37 96-20	BUSHING	1	Diam 20 mm
10	506 37 96-22	BUSHING	1	Diam 22,2 mm
10	506 37 96-25	BUSHING	1	Diam 25,4 mm
10	506 02 88-30	BUSHING	1	Diam 30,5 mm
11	506 28 41-04	LABEL	1	12", Diam 1"
11	506 28 41-02	LABEL	1	12", Diam 20 mm
11	506 28 41-14	LABEL	1	14", Diam 1"
11	506 28 41-12	LABEL	1	14", Diam 20 mm

C K750

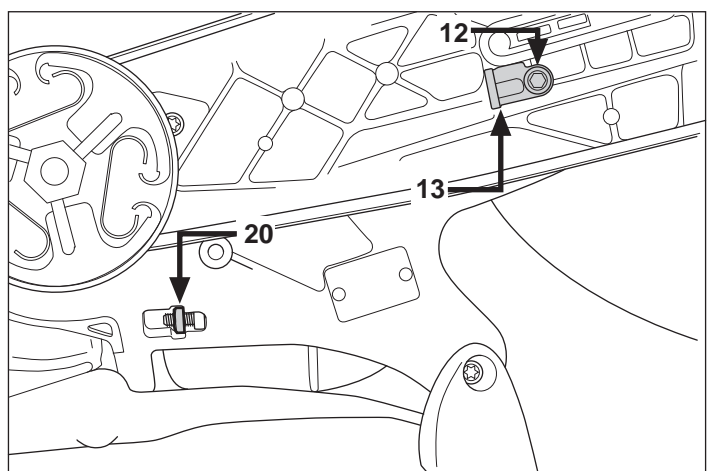
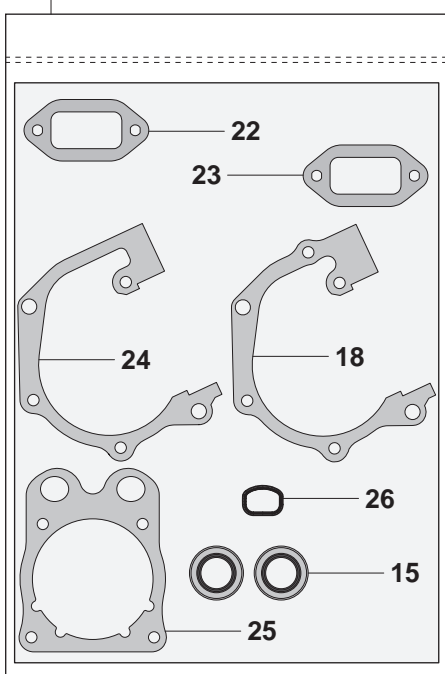
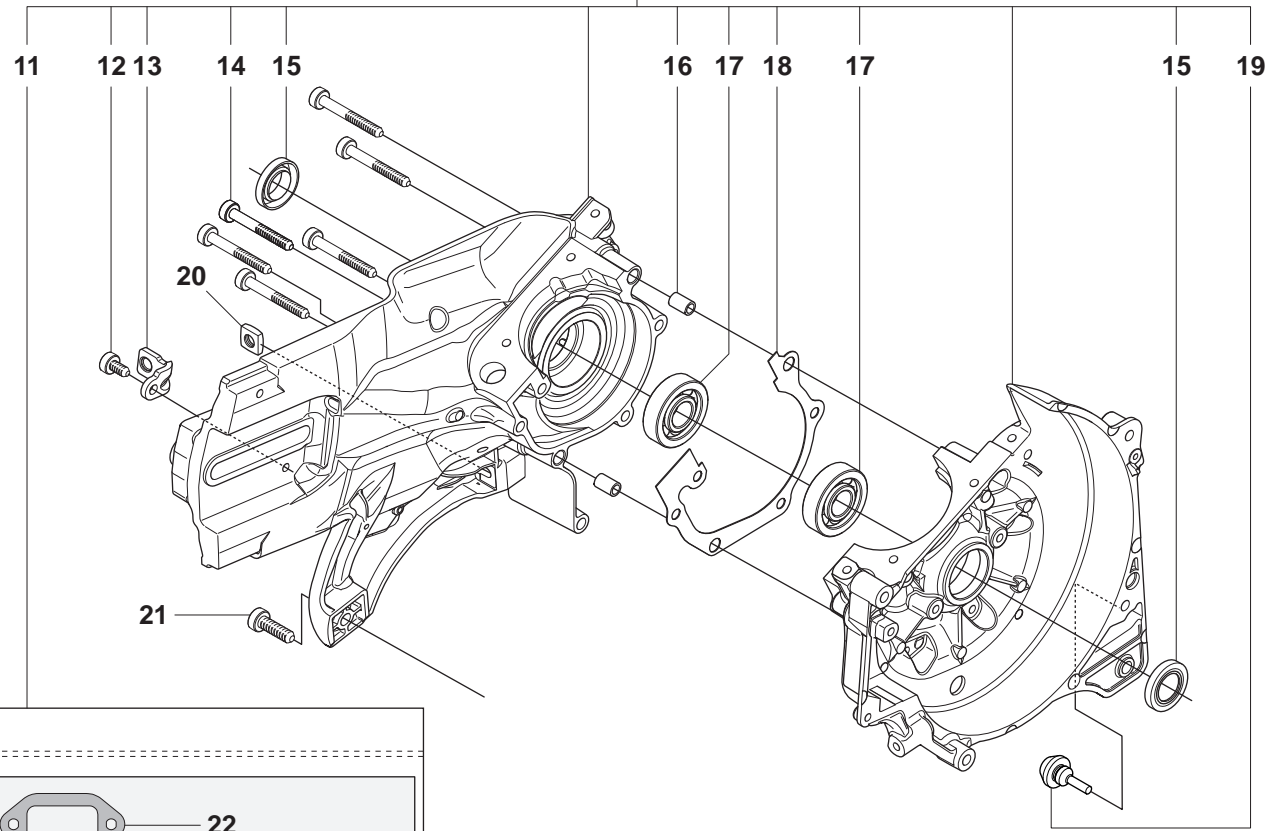
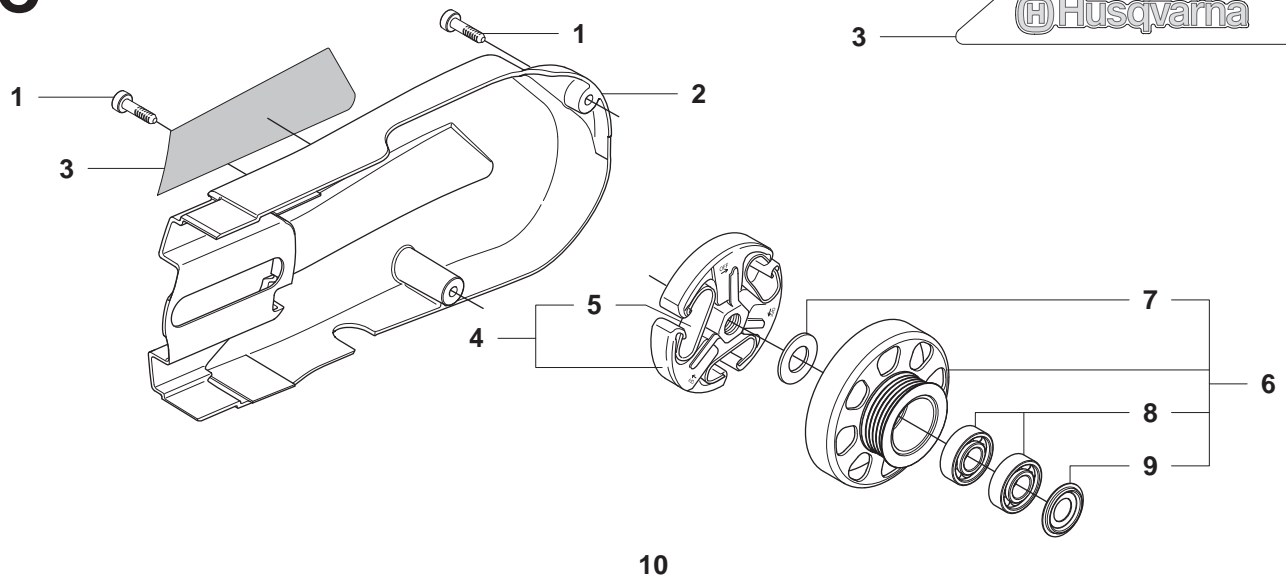

Page C
K750

Pos.	Part No.	Description	Quantity	Notes
1	503 21 53-21	SCREW	2	
2	506 36 91-03	BELT GUARD	1	
3	544 89 11-01	LABEL	1	
4	503 74 44-04	CLUTCH ASSY	1	Incl. 5
5	503 74 43-01	CLUTCH SPRING	1	
6	502 28 92-02	DRIVING PULLEY ASSY	1	Incl. 7 - 9
7	503 23 00-70	WASHER STEEL	1	
8	738 21 01-04	BALL BEARING	2	
9	506 31 69-01	DUST COVER	1	
10	544 88 90-06	CRANKCASE ASSY	1	Incl. 11 - 19
11	506 38 53-05	GASKET KIT	1	
12	503 20 03-12	SCREW	1	
13	544 00 78-01	BRACKET	1	
14	503 21 53-41	SCREW	6	
15	503 26 02-04	SEALING RING	2	
16	501 27 08-01	GUIDE BUSHING	2	
17	738 22 02-25	BALL BEARING	2	
18	506 37 70-03	GASKET CRANKCASE	1	
19	503 84 61-01	BUFFER	1	
20	503 22 65-04	NUT	1	
21	544 06 12-01	SCREW	1	
22	506 41 23-01	GASKET	1	
23	506 37 69-02	GASKET MUFFLER	1	
24	506 37 70-02	GASKET CRANKCASE	1	
25	506 37 67-01	CYLINDER BASE GASKET	1	
26	544 21 93-02	INSERT	1	

D K750

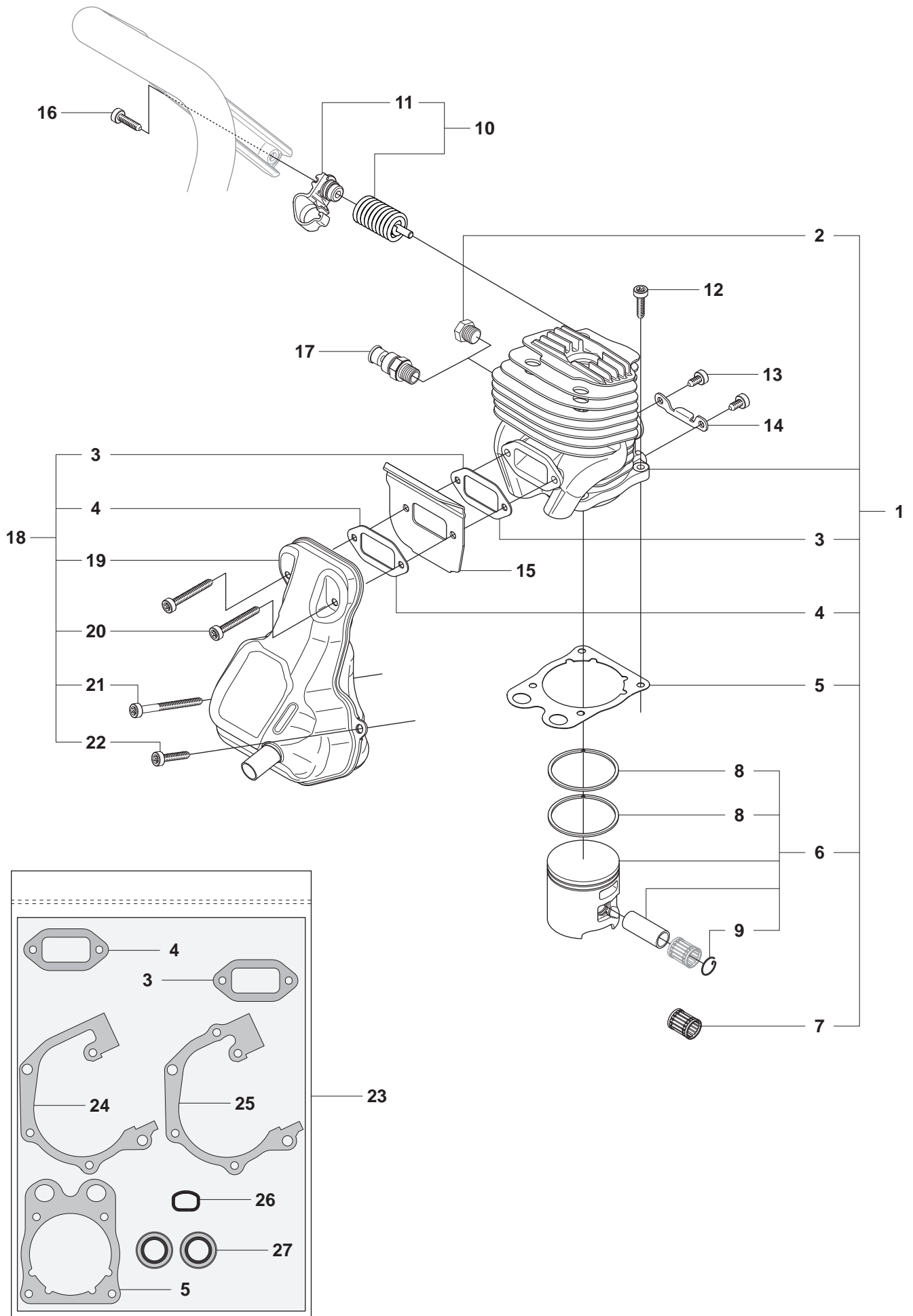

Page D
K750

Pos.	Part No.	Description	Quantity	Notes
1	506 38 61-71	CYLINDER ASSY	1	Incl. 2 - 7
2	503 55 22-01	PLUG	1	
3	506 41 23-01	GASKET	1	
4	506 37 69-02	GASKET MUFFLER	1	
5	506 37 67-01	CYLINDER BASE GASKET	1	
6	506 37 24-01	PISTON ASSY	1	Incl. 8, 9
7	503 25 56-01	NEEDLE BEARING	1	
8	503 28 90-47	PISTON RING	2	
9	737 43 12-00	CIRCLIP	2	
10	506 38 91-02	VIB.INSULATOR	1	Incl. 11
11	544 02 08-02	SPRING RETAINER	1	
12	503 21 53-25	SCREW	4	
13	503 21 53-16	SCREW	2	
14	506 36 88-01	BRACKET	1	
15	506 37 58-02	COOLING PLATE	1	
16	503 21 54-20	SCREW	1	
17	503 71 53-01	DECOMPRESSION VALVE	1	
18	544 00 14-02	MUFFLER KIT	1	Incl. 3, 4, 19 - 22
19	506 36 42-03	MUFFLER ASSY	1	
20	503 21 53-41	SCREW	2	
21	503 21 53-56	SCREW	1	
22	503 21 53-21	SCREW	1	
23	506 38 53-04	GASKET KIT	1	Incl. 3 - 5, 24 - 27
24	506 37 70-02	GASKET CRANKCASE	1	
25	506 37 70-03	GASKET CRANKCASE	1	
26	544 21 93-02	INSERT	1	
27	503 26 02-04	SEALING RING	2	

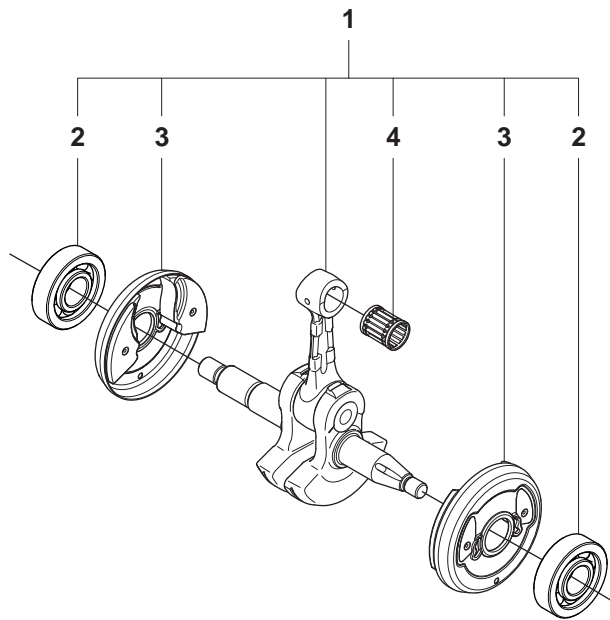

Page E
K750

Pos.	Part No.	Description	Quantity	Notes
1	502 29 50-02	CRANKSHAFT ASSY	1	Incl. 2 - 4
2	738 22 02-25	BALL BEARING	2	
3	537 20 33-01	CUP	2	
4	503 25 56-01	NEEDLE BEARING	1	

F1

K750

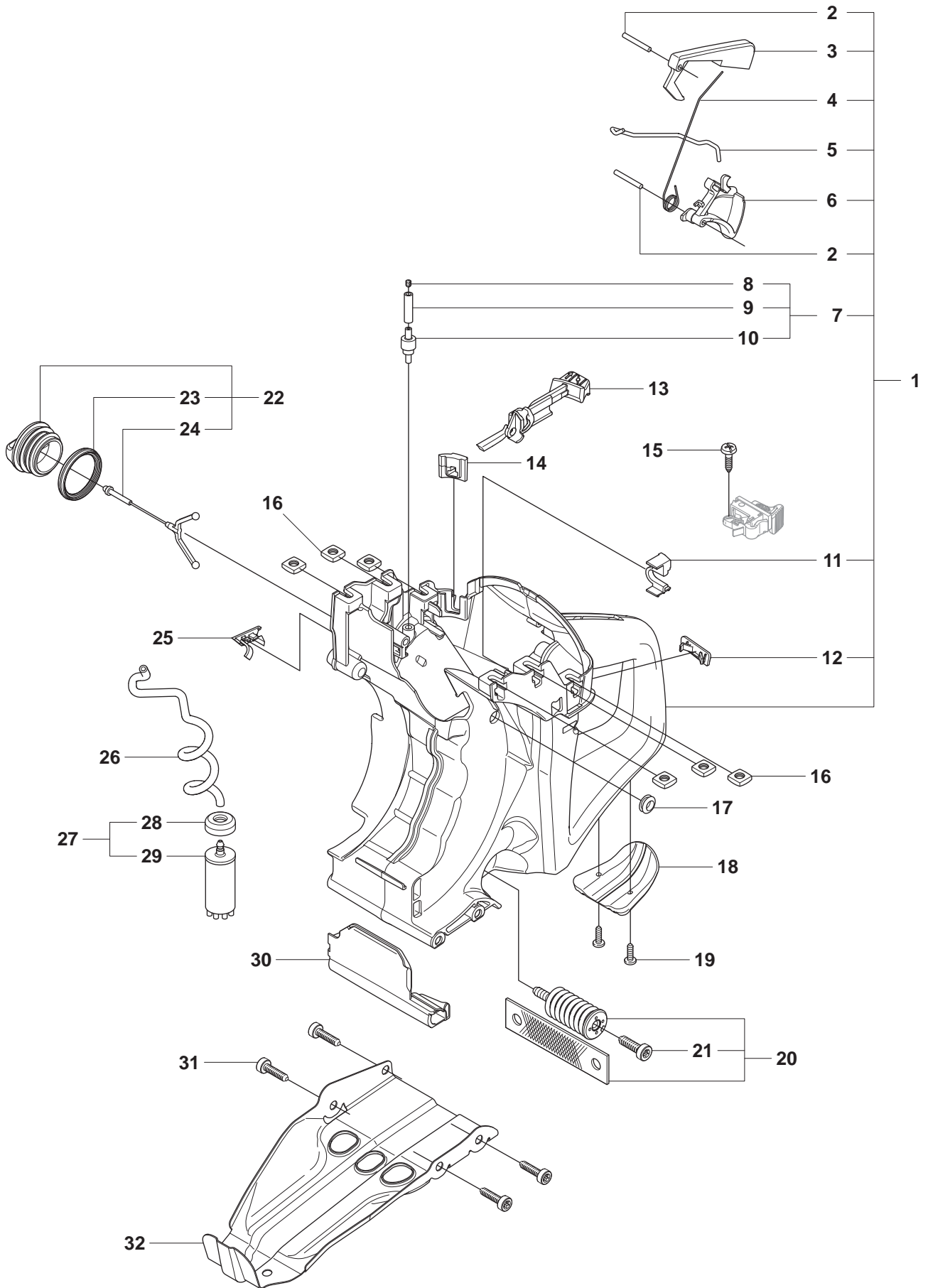

Page F1
K750

Pos.	Part No.	Description	Quantity	Notes
1	506 38 65-12	FUEL TANK	1	Incl. 2 - 7, 11, 12
2	720 12 40-20	PARALLEL PIN	1	
3	506 22 28-02	THROTTLE LOCKOUT	1	
4	506 37 95-01	SPRING	1	
5	506 37 13-01	THROTTLE ROD	1	
6	506 37 20-03	THROTTLE TRIGGER	1	
7	506 38 66-01	TANK VENT ASSY	1	Incl. 8 - 10
8	504 35 72-01	SINTER PLUG	1	
9	501 76 83-28	FUEL HOSE	1	
10	503 16 40-01	TANK VENT	1	
11	544 39 32-01	HOSE CLIP	1	
12	501 37 13-01	LID	1	
13	544 22 90-01	CHOKE CONTROL	1	
14	506 37 80-01	GROMMET	1	
15	503 21 28-06	SCREW	1	
16	503 22 65-04	NUT	6	
17	501 27 13-02	CABLE GROMMET	1	
18	506 38 67-02	GROUND SUPPORT	1	
19	503 21 45-16	SCREW	2	
20	537 21 03-07	VIBRATION ABSORBER	1	Incl. 21
21	544 06 12-01	SCREW	1	
22	506 25 59-03	TANK CAP ASSY	1	Incl. 23, 24
23	506 29 21-01	GASKET	1	
24	503 57 89-01	TANK CAP HOLDER	1	
25	506 39 46-01	CAP	1	
26	503 57 76-03	FUEL HOSE	1	
27	506 26 41-11	FUEL FILTER	1	Incl. 28, 29
28	506 27 11-01	HOSE CLAMP	1	
29	506 26 41-01	FUEL FILTER	1	
30	506 38 15-01	HEAT SHIELD	1	
31	503 21 54-20	SCREW	4	
32	506 37 19-02	BASE PLATE	1	

F2 K750 Oil Guard

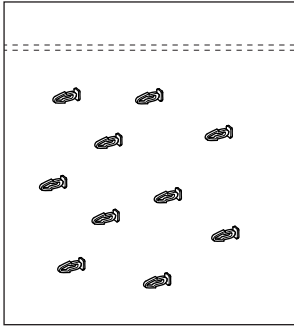

38 C

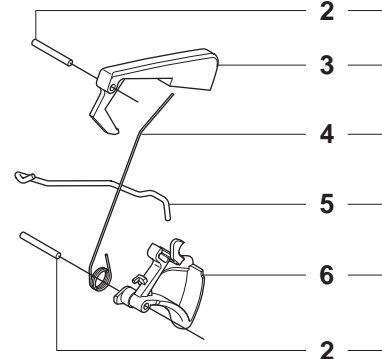

2
3
4
5
6
2

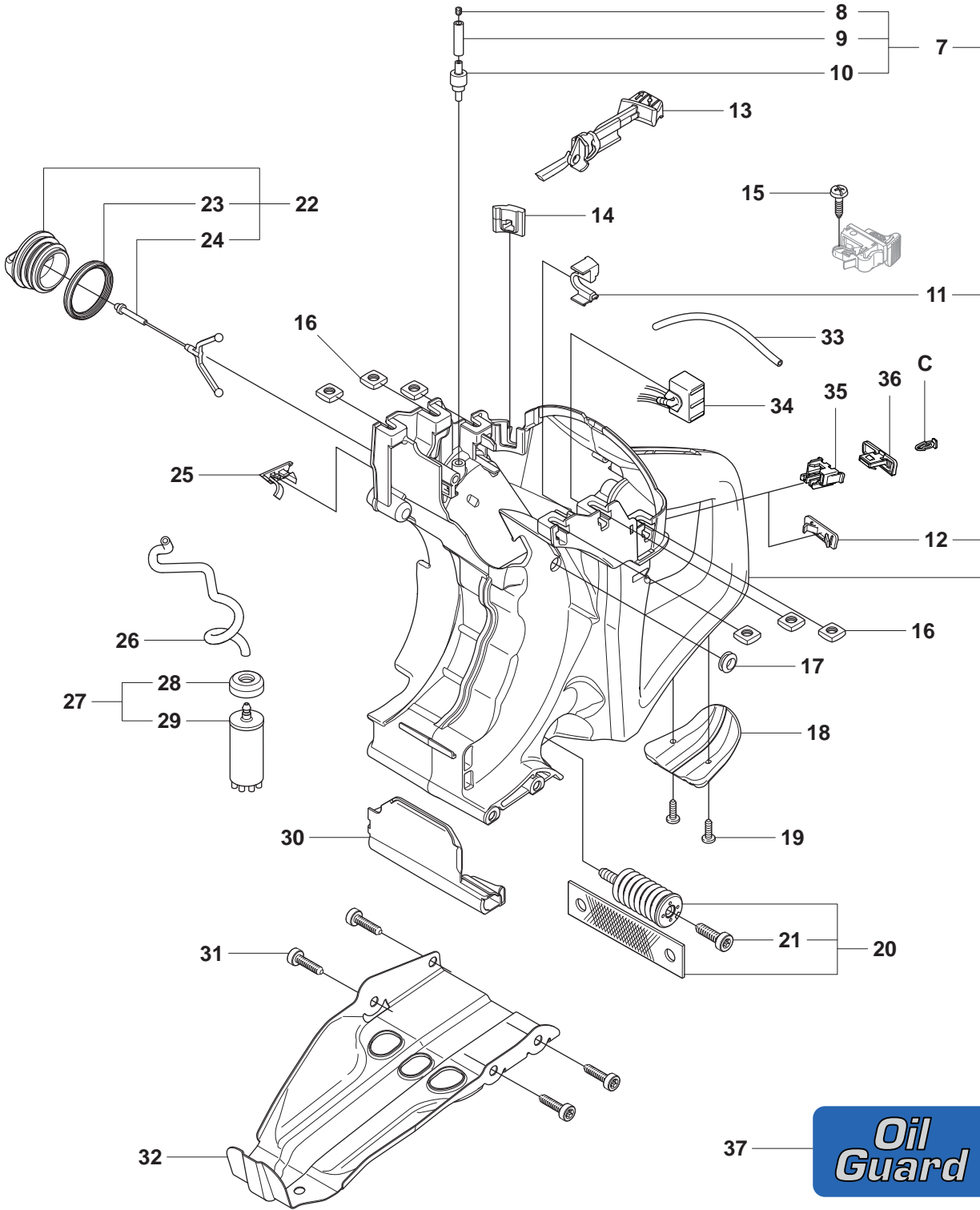

Page F2
K750 Oil Guard

Pos.	Part No.	Description	Quantity	Notes
1	506 38 65-12	FUEL TANK	1	Incl. 2 - 7, 11, 12
2	720 12 40-20	PARALLEL PIN	1	
3	506 22 28-02	THROTTLE LOCKOUT	1	
4	506 37 95-01	SPRING	1	
5	506 37 13-01	THROTTLE ROD	1	
6	506 37 20-03	THROTTLE TRIGGER	1	
7	506 38 66-01	TANK VENT ASSY	1	Incl. 8 - 10
8	504 35 72-01	SINTER PLUG	1	
9	501 76 83-28	FUEL HOSE	1	
10	503 16 40-01	TANK VENT	1	
11	544 39 32-01	HOSE CLIP	1	
12	501 37 13-01	LID	1	
13	544 22 90-01	CHOKE CONTROL	1	
14	506 37 80-01	GROMMET	1	
15	503 21 28-06	SCREW	1	
16	503 22 65-04	NUT	6	
17	501 27 13-02	CABLE GROMMET	1	
18	506 38 67-02	GROUND SUPPORT	1	
19	503 21 45-16	SCREW	2	
20	537 21 03-07	AV-ELEMENT	1	Incl. 21
21	544 06 12-01	SCREW	1	
22	506 25 59-04	TANK CAP ASSY	1	Incl. 23, 24
23	506 29 21-01	GASKET	1	
24	503 57 89-01	TANK CAP HOLDER	1	
25	506 39 46-01	CAP	1	
26	503 57 76-03	FUEL HOSE	1	
27	506 26 41-11	FUEL FILTER	1	Incl. 28, 29
28	506 27 11-01	HOSE CLAMP	1	
29	506 26 41-01	FUEL FILTER	1	
30	506 38 15-01	HEAT SHIELD	1	
31	503 21 54-20	SCREW	4	
32	506 37 19-02	BASE PLATE	1	
33	544 32 49-37	FUEL HOSE	1	Oil Guard
34	544 38 41-01	ELECTRONIC BOX	1	Oil Guard
35	501 01 88-01	HOUSING	1	Oil Guard
36	501 01 94-01	SWITCH	1	Oil Guard
37	501 31 89-01	LABEL	1	Oil Guard
38	503 23 33-01	CUP SPRING	1	Oil Guard, Incl. 10 springs

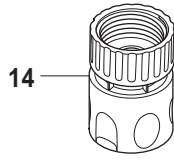

13

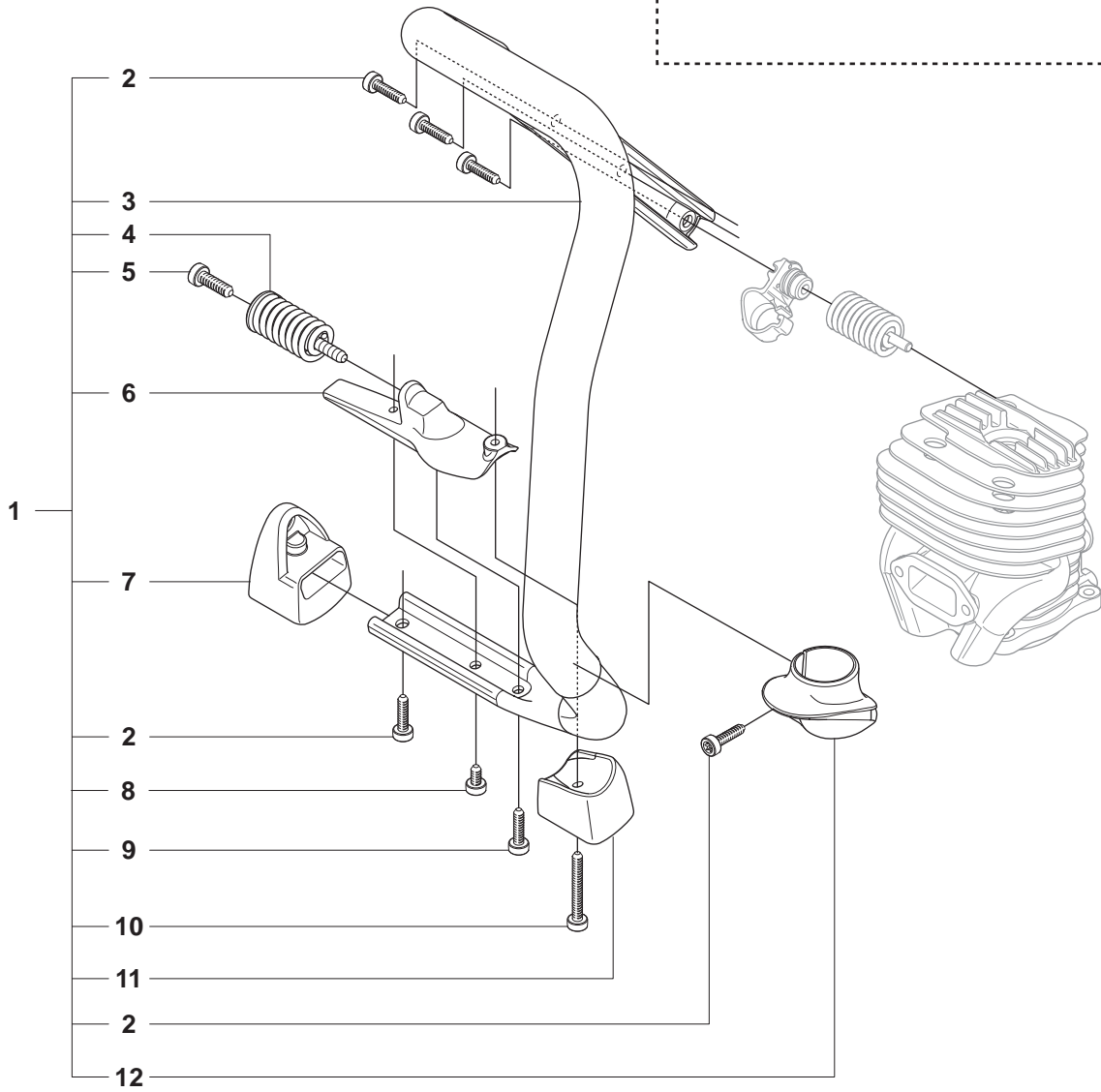
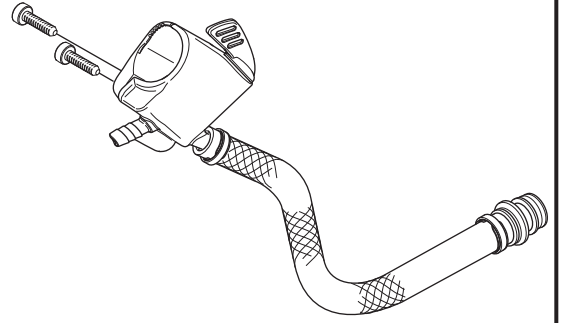

Page G
K750

Pos.	Part No.	Description	Quantity	Notes
1	506 38 58-02	HANDLE	1	Incl. 2 - 12
2	503 21 54-20	SCREW	5	
3	506 37 11-03	FRONT HANDLE	1	
4	537 21 03-08	AV-ELEMENT	1	
5	544 06 12-01	SCREW	1	
6	506 37 72-02	SPRING RETAINER	1	
7	506 37 55-02	GROUND SUPPORT	1	
8	503 21 53-16	SCREW	1	
9	503 21 53-21	SCREW	1	
10	503 21 53-40	SCREW	1	
11	506 37 56-02	GROUND SUPPORT	1	
12	506 38 71-02	STOP	1	
13	506 38 59-04	HOSE	1	
14	503 26 60-01	COUPLER	1	

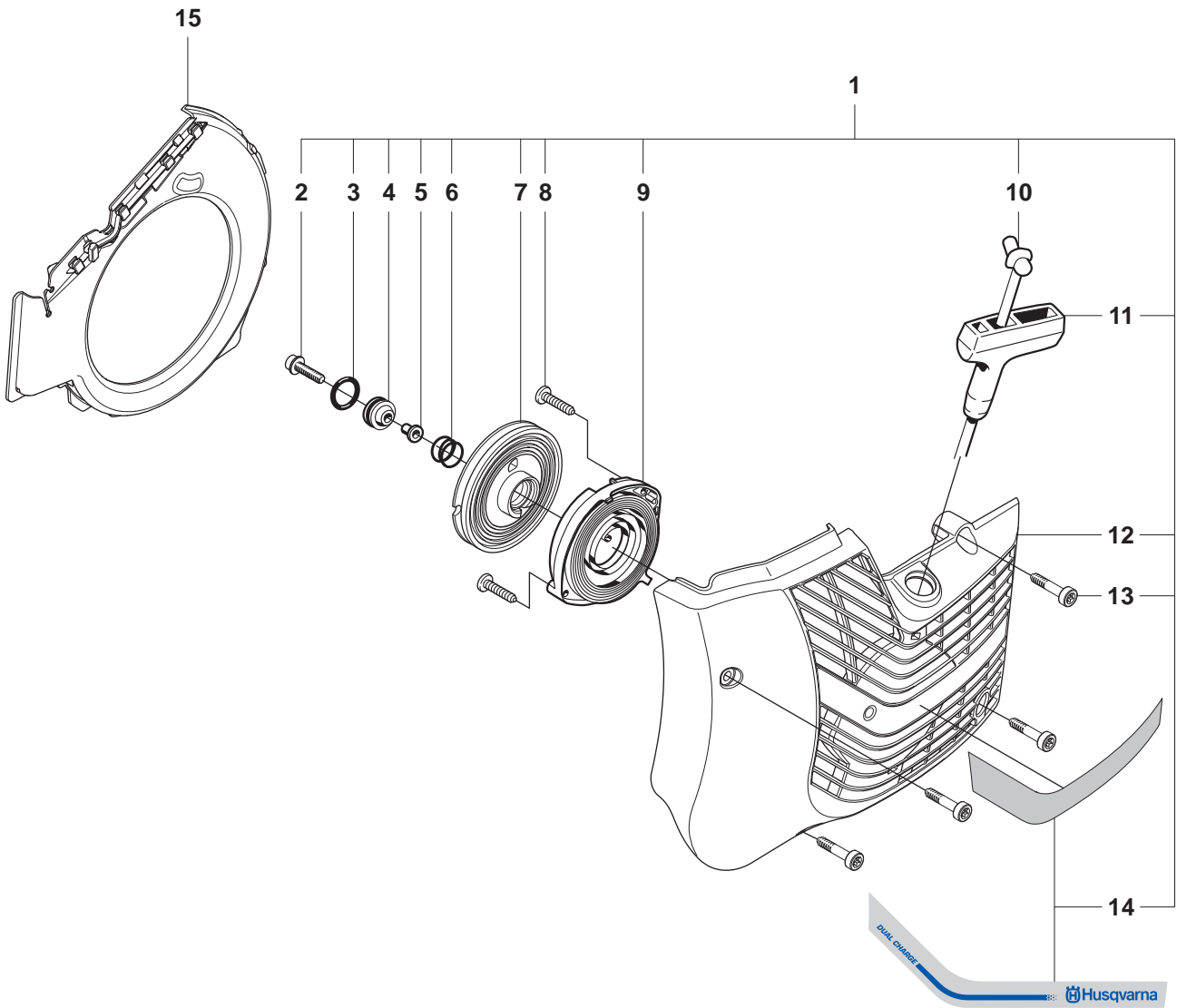

Page H
K750

Pos.	Part No.	Description	Quantity	Notes
1	506 38 56-12	STARTER	1	Incl. 2 - 14
2	503 21 67-22	SCREW	1	
3	740 43 13-00	O-RING	1	
4	506 25 14-01	GROMMET	1	
5	506 26 31-01	SPACING SLEEVE	1	
6	506 25 30-01	COMPRESSION SPRING	1	
7	506 25 81-02	STARTER PULLEY	1	
8	503 21 28-10	SCREW	2	
9	506 25 89-01	RECOIL SPRING	1	
10	506 33 56-15	STARTER CORD	1	
11	503 12 79-01	STARTER HANDLE	1	
12	506 36 92-03	STARTER COVER	1	
13	503 21 53-21	SCREW	4	
14	544 89 08-01	LABEL	1	
15	544 38 39-01	AIR CONDUCTOR	1	

J

K750

K750 Oil Guard

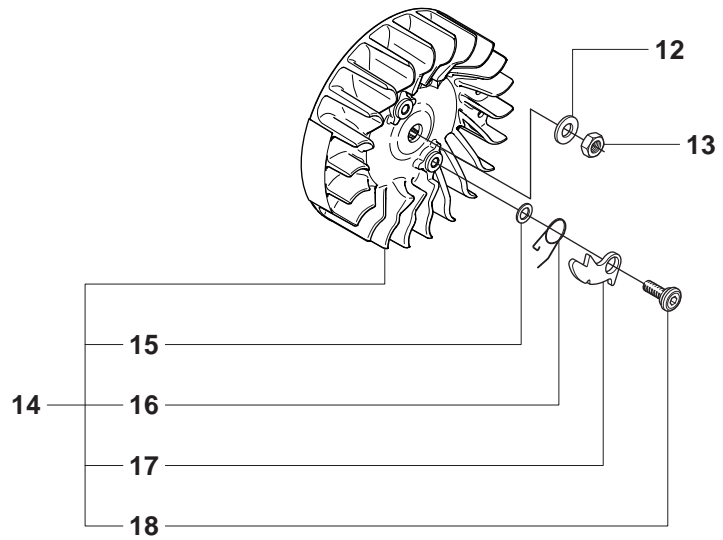
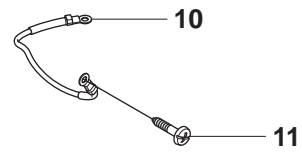
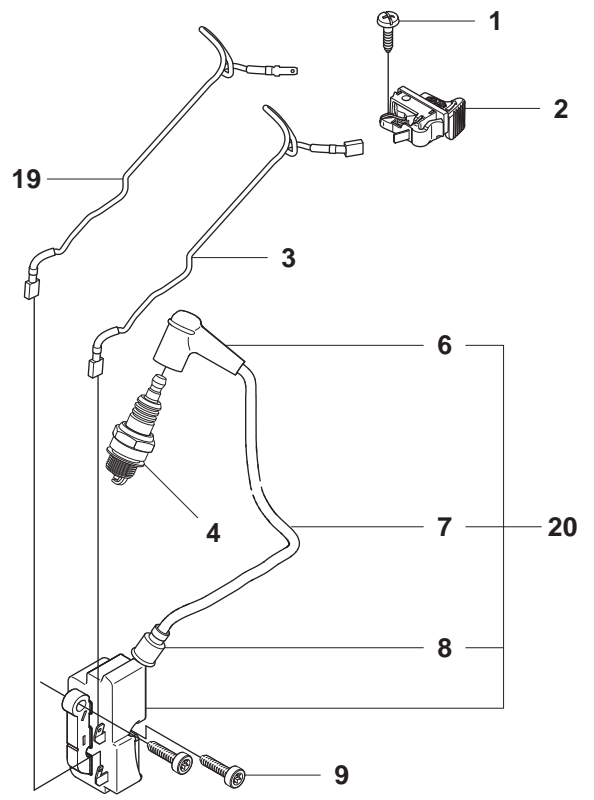
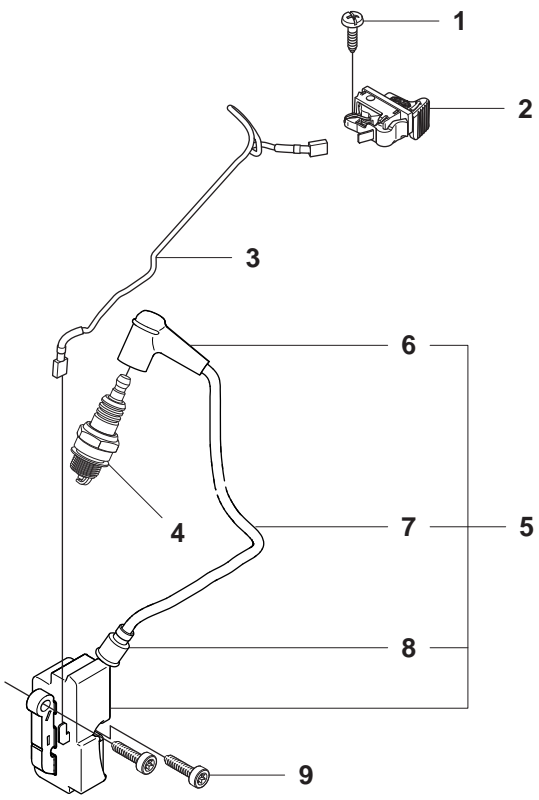

Page J
K750

Pos.	Part No.	Description	Quantity	Notes
1	503 21 28-06	SCREW	1	
2	506 31 86-02	STOP SWITCH	1	
3	544 97 93-01	CABLE	1	
4	503 23 51-09	SPARK PLUG	1	RCJ 6 Y
5	544 04 75-02	IGNITION MODULE	1	Incl. 6 - 8
6	501 48 54-02	SPARK PLUG CAP	1	
7	506 38 78-34	IGNITION CABLE	1	
8	505 27 75-16	ISOLERHATT	1	
9	503 21 53-20	SCREW	2	
10	506 37 85-01	CABLE	1	
11	503 21 28-10	SCREW	1	
12	503 23 01-01	WASHER STEEL	1	
13	503 22 10-11	NUT	1	
14	506 27 27-10	FLYWHEEL	1	Incl. 15 - 18
15	503 23 00-42	WASHER STEEL	2	
16	501 63 48-01	SPRING	2	
17	501 67 32-03	PAWL	2	
18	501 81 99-01	SCREW	2	
19	544 38 49-01	CABLE	1	Oil Guard
20	544 84 30-02	IGNITION MODULE	1	Oil Guard Incl. 6 - 8

K K750

Decompression Valve
Push before starting

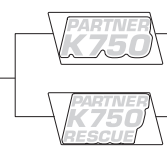
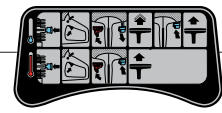
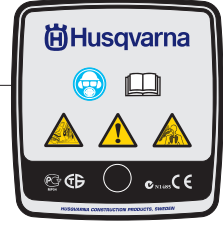
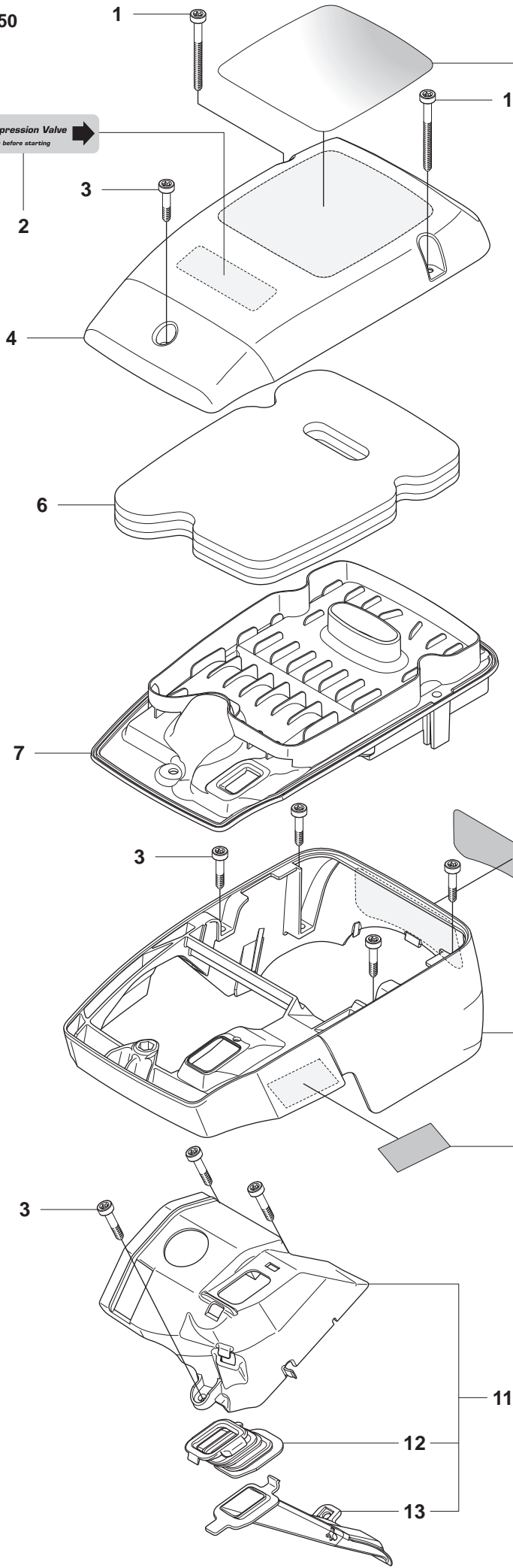

Page K
K750

Pos.	Part No.	Description	Quantity	Notes
1	503 21 53-56	SCREW	2	
2	544 87 46-01	LABEL	1	
3	503 21 53-21	SCREW	8	
4	506 36 68-02	FILTER COVER	1	
5	544 87 44-02	LABEL	1	CE
5	544 97 25-01	LABEL	1	EPA USA
5	544 97 25-03	LABEL	1	EPA Canada
6	506 36 71-01	PREFILTER	1	
7	506 36 69-02	FILTER BOTTOM	1	
8	506 39 84-02	CYLINDER COVER ASSY	1	Incl. 9, 10
9	544 89 09-01	LABEL	1	
10	544 89 10-01	LABEL	1	
10	544 89 10-02	LABEL	1	Rescue
11	506 38 62-01	COVER	1	Incl. 12, 13
12	506 37 04-01	BELLOWS	1	
13	506 37 03-01	AIR NOZZLE	1	



K750

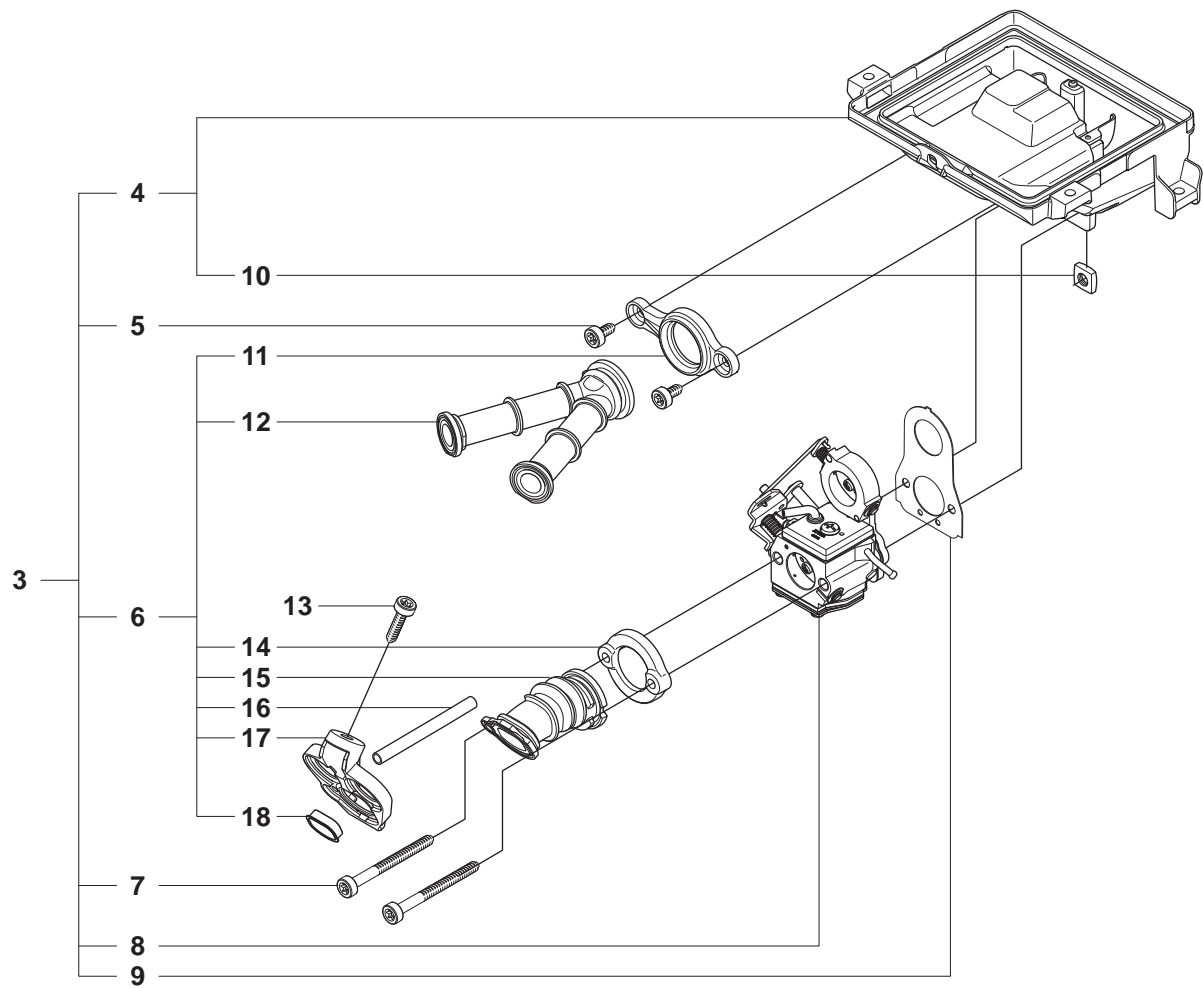
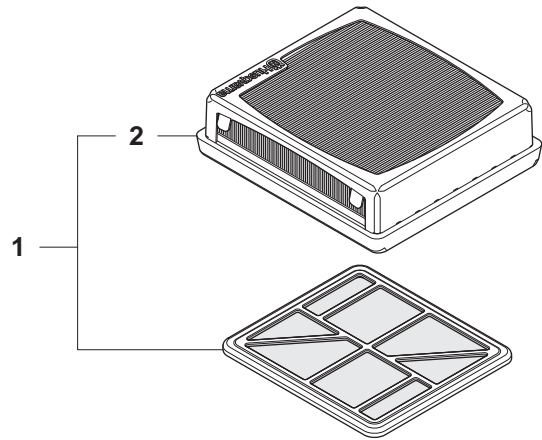

Page L
K750

Pos.	Part No.	Description	Quantity	Notes
1	544 18 16-02	FILTER	1	Incl. 2
2	506 36 72-03	AIR FILTER PAPER	1	
3	506 38 55-06	CARBURETTOR BRACKET	1	Incl. 4 - 9
4	506 39 32-02	CARBURETTOR BRACKET	1	Incl. 10
5	503 21 53-10	SCREW	2	
6	506 38 64-02	INLET PIPE	1	Incl. 11, 12. 14 - 18
7	503 21 53-56	SCREW	2	
8	503 28 32-09	CARBURETTOR	1	Zama C3-EL29
9	506 37 68-03	GASKET CARBURETTOR	1	
10	503 22 65-04	NUT	4	
11	506 37 06-01	FLANGE INLET PIPE	1	
12	506 36 98-01	INLET PIPE	1	
13	503 21 53-20	SCREW	1	
14	506 37 05-01	FLANGE INLET PIPE	1	
15	506 36 97-01	INLET PIPE	1	
16	503 40 06-09	IMPULSE HOSE	1	
17	506 39 52-01	PLATE	1	
18	544 21 93-01	INSERT	1	

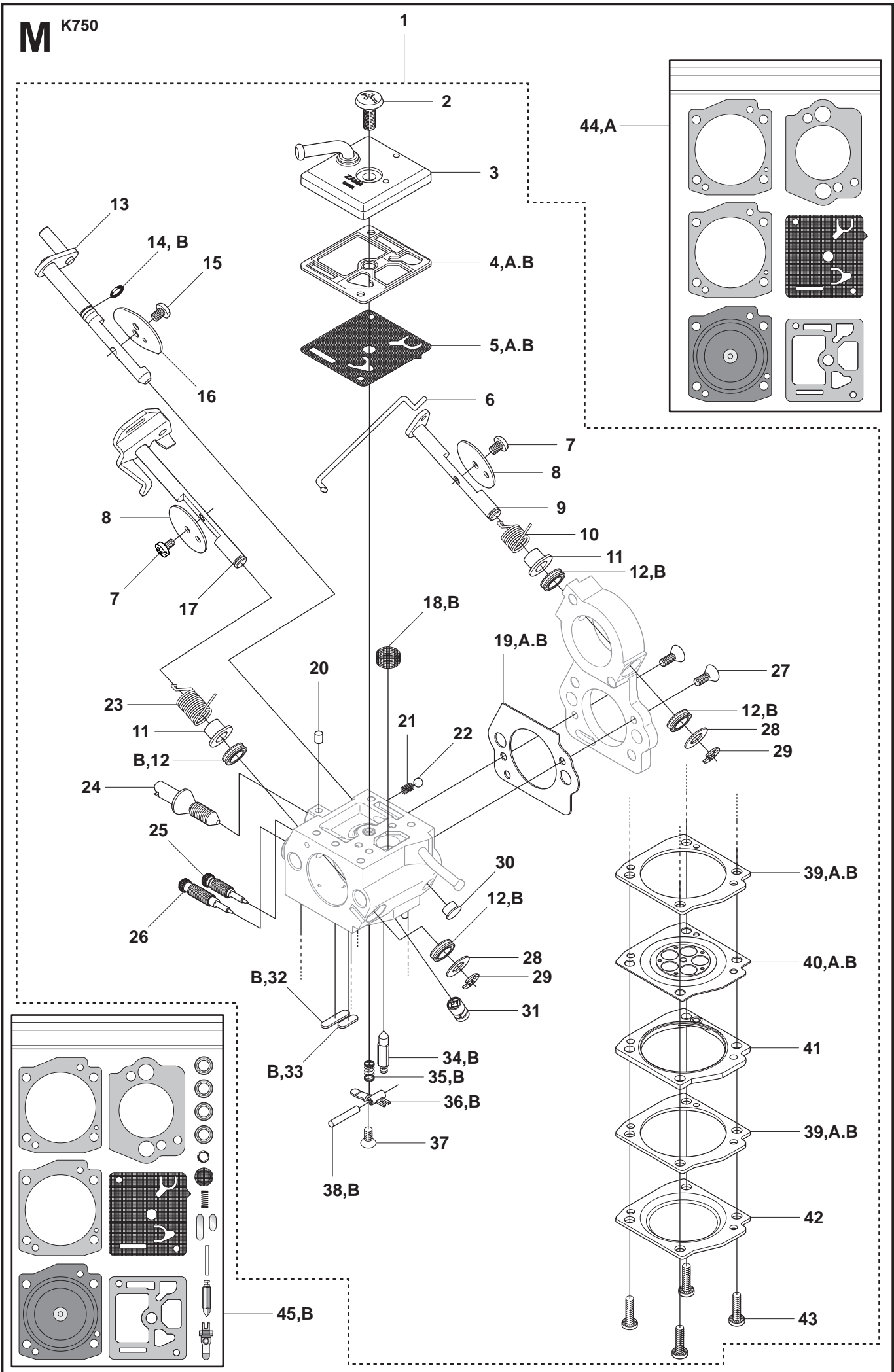

Page M
K750

Pos.	Part No.	Description	Quantity	Notes
1	503 28 32-09	CARBURETTOR	1	Zama C3-EL29, Incl. 2 - 43
2	503 47 96-01	SCREW	1	
3	544 83 64-01	PUMP COVER	1	
4	503 61 66-01	GASKET PUMP	1	
5	506 39 60-01	DIAPHRAGM PUMP	1	
6	506 39 65-01	ROD	1	
7	544 08 22-01	SCREW	2	
8	537 17 70-01	VALVE	2	
9	506 39 71-01	SHAFT ASSY	1	
10	506 39 75-01	SPRING	1	
11	506 39 54-01	COLLAR	2	
12	506 39 64-01	QUAD RING	4	
13	506 39 73-01	SHAFT ASSY CHOKE	1	
14	506 39 90-01	O-RING	1	
15	503 48 18-01	SCREW	1	
16	506 39 78-01	VALVE	1	
17	506 39 74-01	SHAFT ASSY	1	
18	503 53 57-01	STRAINER	1	
19	506 39 58-01	GASKET	1	
20	503 48 11-01	PIECE	1	
21	537 01 26-01	SPRING	1	
22	537 01 25-01	BALL	1	
23	544 83 65-01	SPRING	1	
24	506 39 72-01	SCREW	1	
25	506 39 70-01	SCREW	1	
26	506 39 69-01	SCREW	1	
27	537 38 51-01	SCREW	2	
28	506 39 79-01	WASHER	2	
29	537 38 52-01	E-CLIP	2	
30	506 39 91-01	PLUG	1	
31	506 39 61-01	NOZZLE ASSY	1	
32	503 53 56-01	PLUG WELCH	1	
33	537 17 78-01	PLUG	1	
34	537 17 62-01	VALVE	1	
35	537 27 34-01	SPRING	1	
36	537 17 64-01	LEVER	1	
37	544 08 21-01	SCREW	1	
38	503 48 00-01	PIN RETAINING SCREW	1	
39	506 39 62-01	GASKET	2	
40	506 39 57-01	DIAPHRAGM ASSY	1	
41	506 39 55-01	COVER	1	
42	506 39 56-01	COVER	1	
43	506 39 66-01	SCREW	4	
44	506 40 99-01	GASKET KIT	1	Incl. 4, 5, 19, 39, 40
45	506 41 00-01	GASKET KIT CARB	1	Incl. 4, 5, 12, 14, 32 - 36, 38 - 40

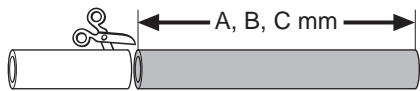
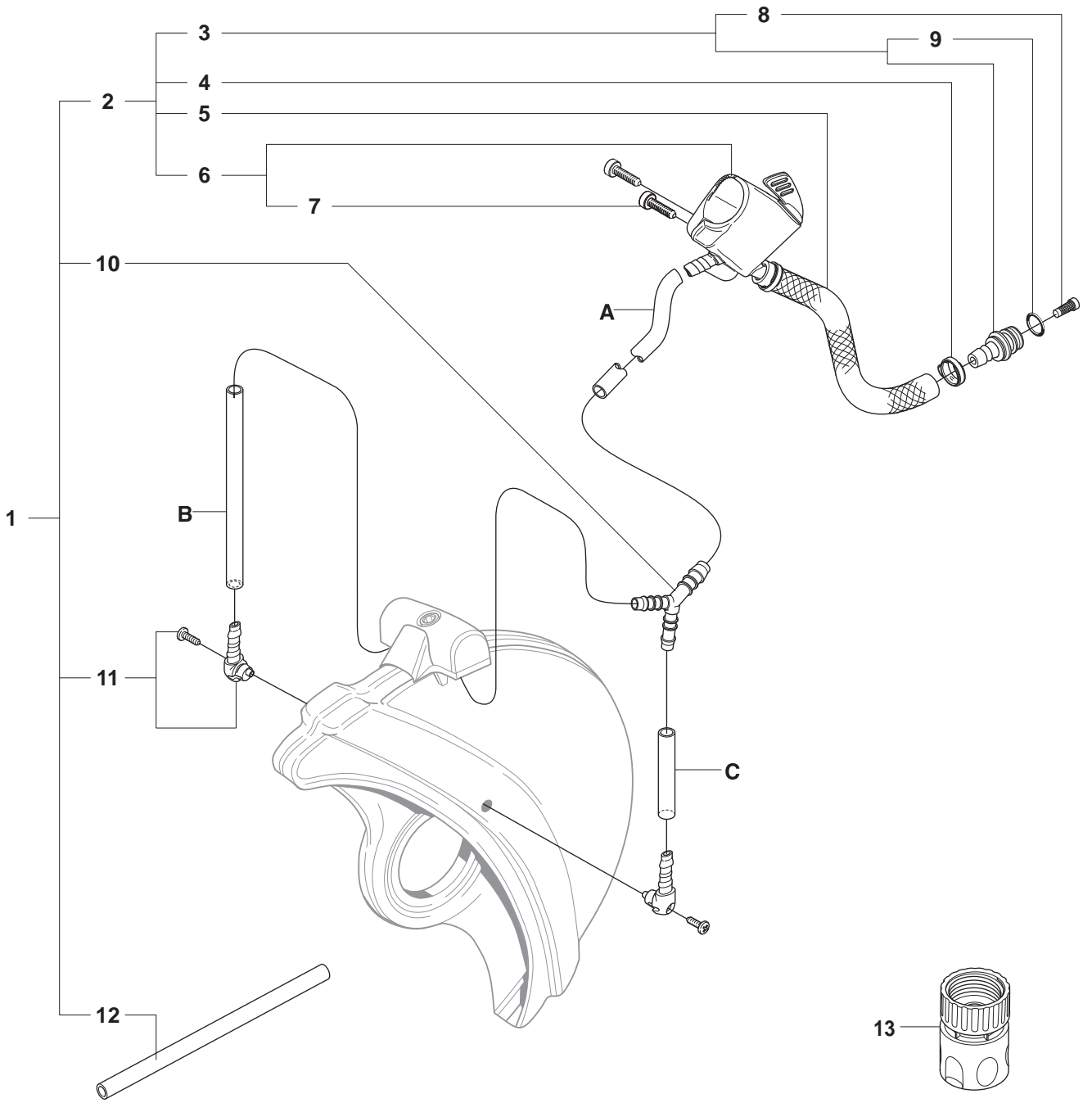

Product	A (mm)	B (mm)	C (mm)
K750 12"	240	240	45
K750 14"	240	280	45

Pos.	Part No.	Description	Quantity	Notes
1	544 00 31-02	WATER HOSE KIT	1	Incl. 2, 10, 11, 12
2	506 38 59-04	HOSE	1	Incl. 3, 4, 5, 6
3	506 29 57-02	NIPPLE	1	Incl. 8, 9
4	506 09 56-06	HOSE CLAMP	2	
5	506 09 75-02	HOSE	1	L=230 mm
6	506 38 60-12	VALVE ASSY	1	Incl. 7
7	503 21 54-20	SCREW	2	
8	506 29 88-01	FILTER	1	
9	503 26 30-21	O-RING	1	
10	506 32 87-01	Y-TUBE	1	
11	506 29 56-01	NIPPLE	2	
12	506 09 58-24	HOSE	1	800 mm
13	503 26 60-01	COUPLER	1	

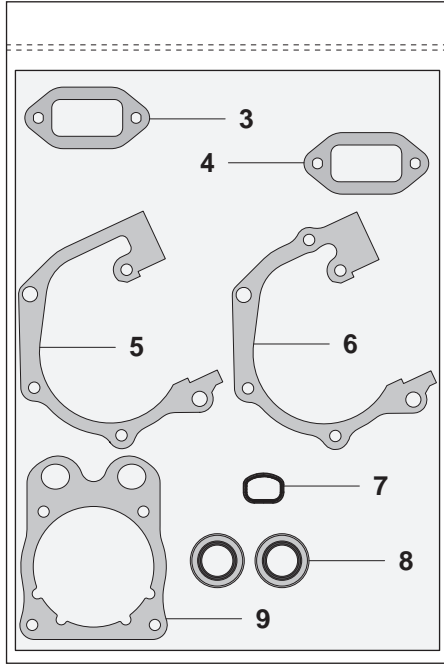

2

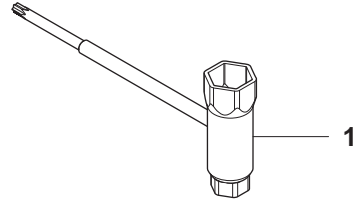

1

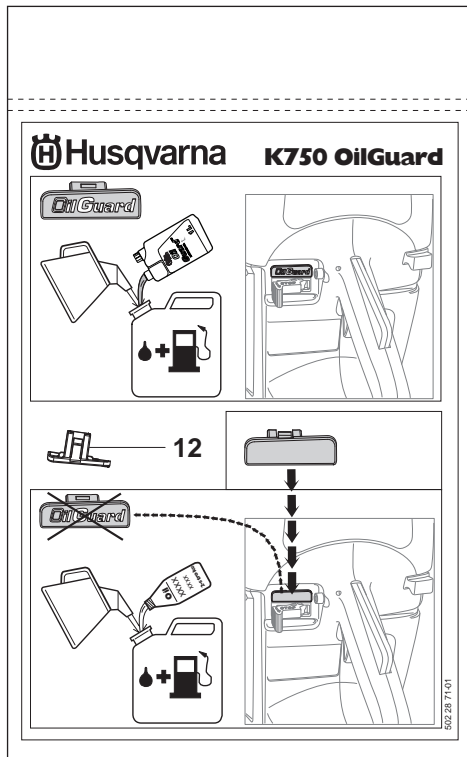

11

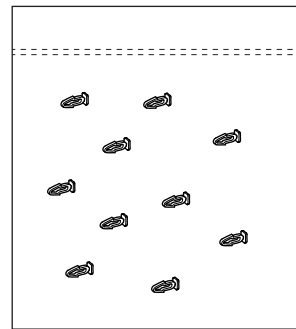

10

Page P
K750

Pos.	Part No.	Description	Quantity	Notes
1	506 38 26-01	COMBINATION TOOL	1	
2	506 38 53-04	GASKET KIT	1	Incl. 3 - 8
3	506 41 23-01	GASKET	1	
4	506 37 69-02	GASKET MUFFLER	1	
5	506 37 70-02	GASKET CRANKCASE	1	
6	506 37 70-03	GASKET CRANKCASE	1	
7	544 21 93-02	INSERT	1	
8	506 37 67-02	CYLINDER BASE GASKET	1	
9	503 26 02-04	SEALING RING	2	
10	502 23 33-01	KIT BREAK PIN	1	Incl. 10 Springs
11	502 28 70-01	KIT SWITCH OFF	1	
12	501 01 95-01	SWITCH	1	

Q K750

K12 FD FIRE-RESCUE

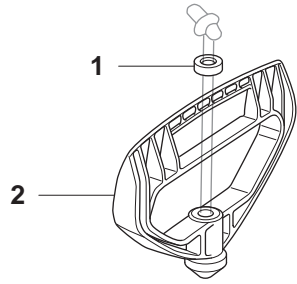

Rescue

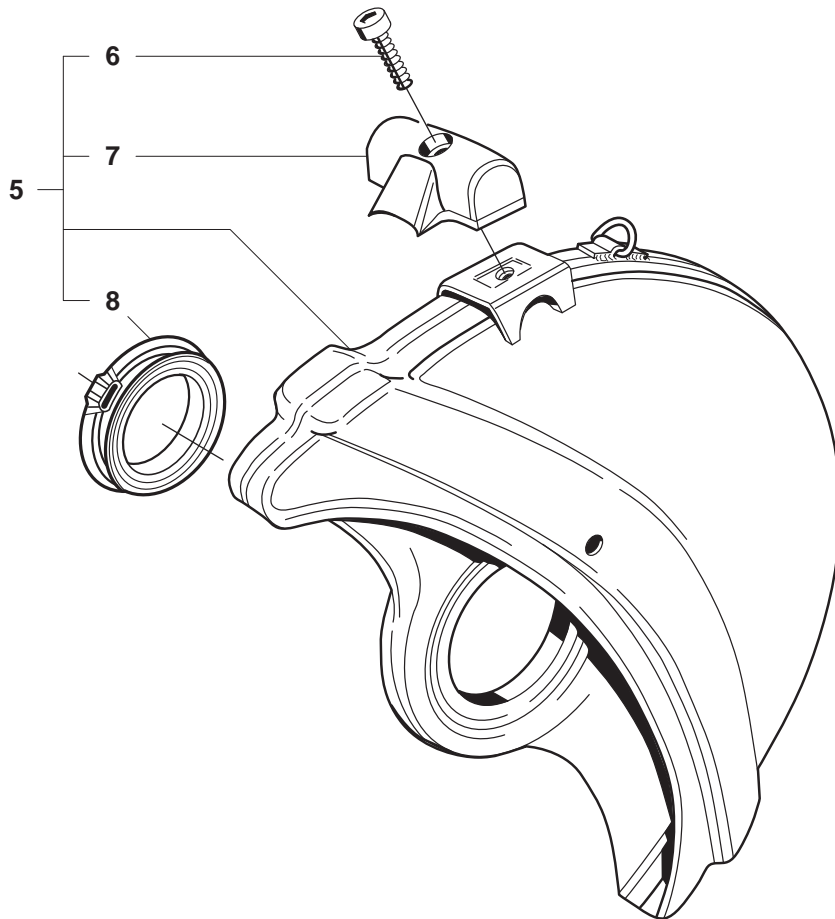

9 **Husqvarna Rescue**
max 5400 rpm
Ø25.4 (Ø1"), Ø350 (Ø14")

10 **ATTENTION**
This product has been modified for use by
trained fire rescue personnel only.

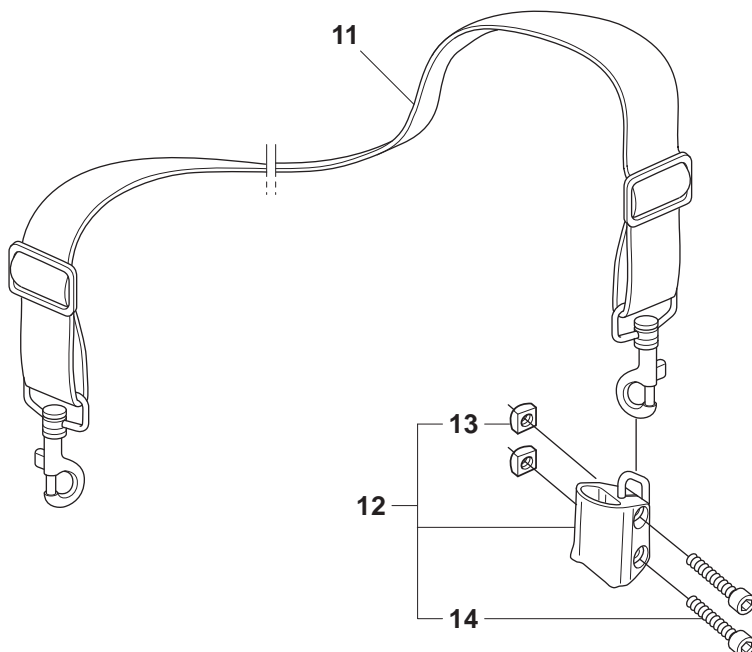

Page Q
K750

Pos.	Part No.	Description	Quantity	Notes
1	503 14 29-02	WASHER	1	
2	506 29 75-02	STARTER HANDLE	1	
3	506 32 20-02	LABEL	1	
4	506 30 23-02	LABEL	1	
5	506 34 05-28	WHEEL GUARD ASSY	1	Rescue 12". Incl. 6 - 8
6	725 53 31-55	SCREW	1	
7	506 34 46-02	HANDLE	1	
8	506 26 63-02	LINING	2	
9	544 89 06-02	LABEL	1	
10	506 32 22-02	LABEL	1	
11	506 29 76-01	SHOULDER STRAP	1	
12	506 30 25-04	BRACKET	1	Incl. 13, 14
13	503 22 65-04	NUT	2	
14	530 21 53-16	SCREW	2	

1

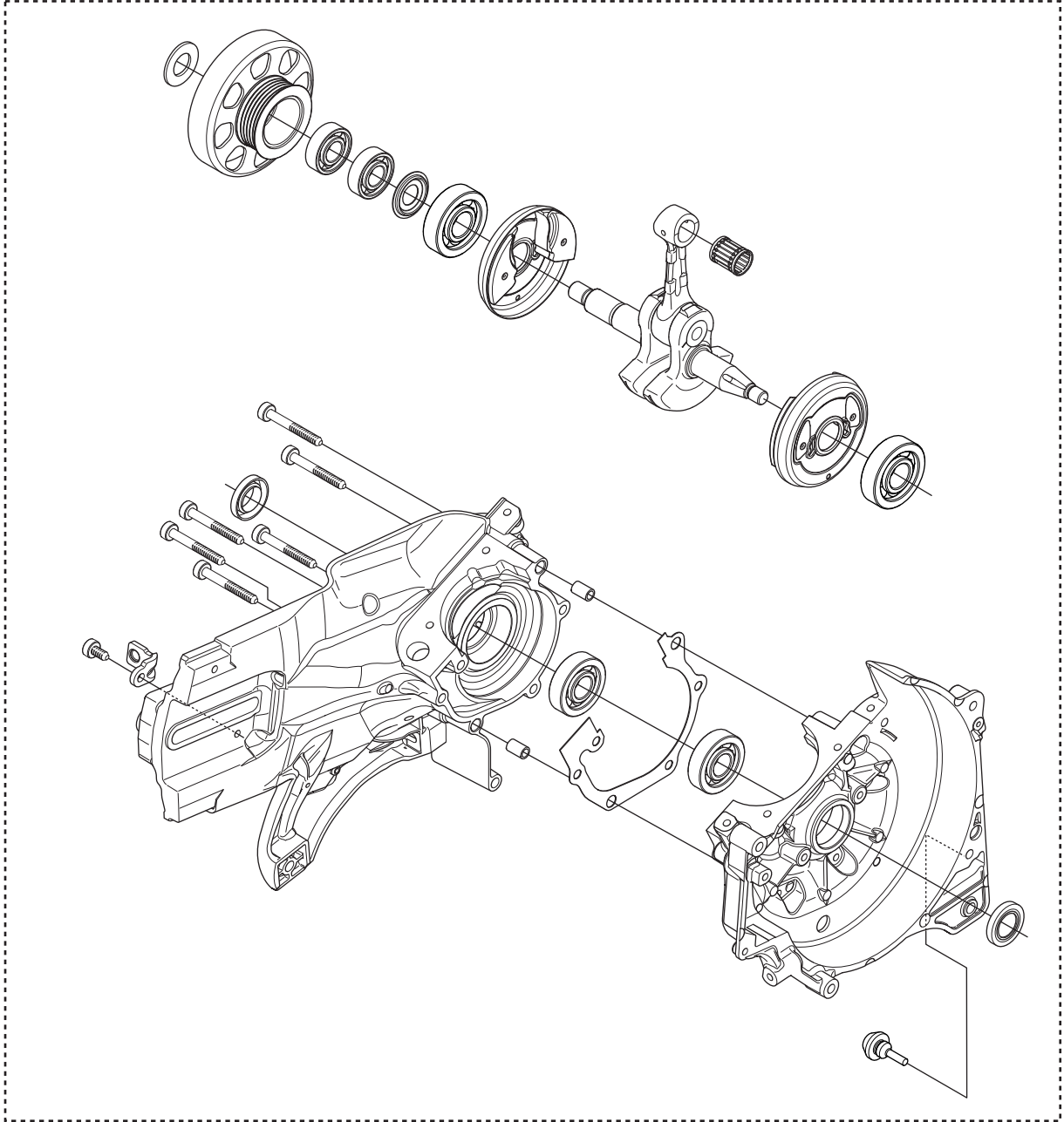

Page R
K750

Pos.	Part No.	Description	Quantity	Notes
1	544 88 90-07	CRANKCASE ASSY	1	

S

K750

1

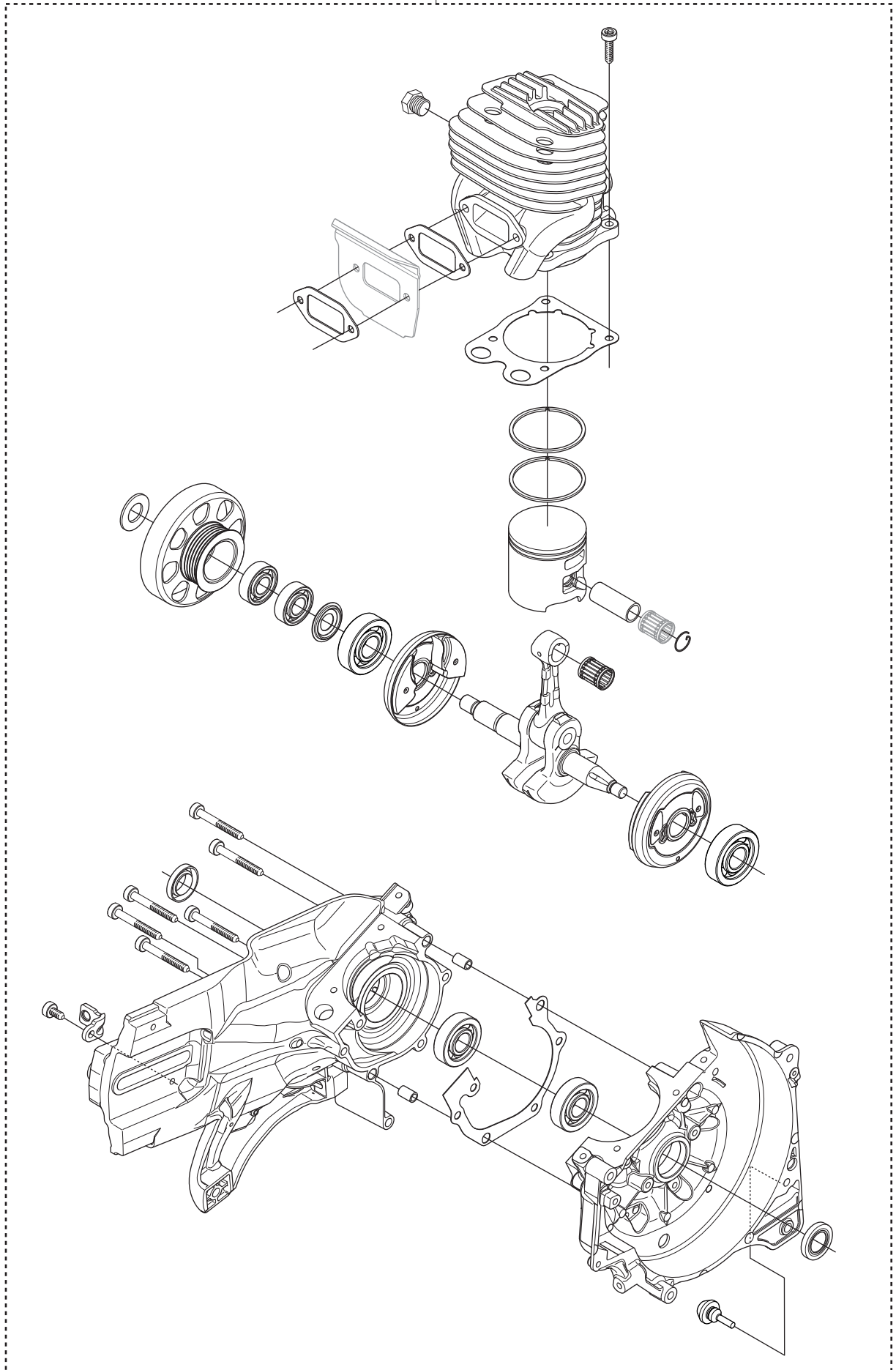

Page S
K750

Pos.	Part No.	Description	Quantity	Notes
1	544 88 90-08	CRANKCASE ASSY	1	