



# Operating Instructions and Parts Manual

## Variable Speed Turret Mill

Model JTM-4VS



### JET

427 New Sanford Road  
LaVergne, Tennessee 37086  
Ph.: 800-274-6848  
[www.jettools.com](http://www.jettools.com)

**Part No. M-690182**  
Revision I 01/2016  
Copyright © 2015 JET

# Warranty and Service

JET® warrants every product it sells against manufacturers' defects. If one of our tools needs service or repair, please contact Technical Service by calling 1-800-274-6846, 8AM to 5PM CST, Monday through Friday.

## Warranty Period

The general warranty lasts for the time period specified in the literature included with your product or on the official JET branded website.

- JET products carry a limited warranty which varies in duration based upon the product. (See chart below)
- Accessories carry a limited warranty of one year from the date of receipt.
- Consumable items are defined as expendable parts or accessories expected to become inoperable within a reasonable amount of use and are covered by a 90 day limited warranty against manufacturer's defects.

## Who is Covered

This warranty covers only the initial purchaser of the product from the date of delivery.

## What is Covered

This warranty covers any defects in workmanship or materials subject to the limitations stated below. This warranty does not cover failures due directly or indirectly to misuse, abuse, negligence or accidents, normal wear-and-tear, improper repair, alterations or lack of maintenance. JET woodworking machinery is designed to be used with Wood. Use of these machines in the processing of metal, plastics, or other materials outside recommended guidelines may void the warranty. The exceptions are acrylics and other natural items that are made specifically for wood turning.

## Warranty Limitations

Woodworking products with a Five Year Warranty that are used for commercial or industrial purposes default to a Two Year Warranty. Please contact Technical Service at 1-800-274-6846 for further clarification.

## How to Get Technical Support

Please contact Technical Service by calling 1-800-274-6846. **Please note that you will be asked to provide proof of initial purchase when calling.** If a product requires further inspection, the Technical Service representative will explain and assist with any additional action needed. JET has Authorized Service Centers located throughout the United States. For the name of an Authorized Service Center in your area call 1-800-274-6846 or use the Service Center Locator on the JET website.

## More Information

JET is constantly adding new products. For complete, up-to-date product information, check with your local distributor or visit the JET website.

## How State Law Applies

This warranty gives you specific legal rights, subject to applicable state law.

## Limitations on This Warranty

JET LIMITS ALL IMPLIED WARRANTIES TO THE PERIOD OF THE LIMITED WARRANTY FOR EACH PRODUCT. EXCEPT AS STATED HEREIN, ANY IMPLIED WARRANTIES OF MERCHANTABILITY AND FITNESS FOR A PARTICULAR PURPOSE ARE EXCLUDED. SOME STATES DO NOT ALLOW LIMITATIONS ON HOW LONG AN IMPLIED WARRANTY LASTS, SO THE ABOVE LIMITATION MAY NOT APPLY TO YOU.

JET SHALL IN NO EVENT BE LIABLE FOR DEATH, INJURIES TO PERSONS OR PROPERTY, OR FOR INCIDENTAL, CONTINGENT, SPECIAL, OR CONSEQUENTIAL DAMAGES ARISING FROM THE USE OF OUR PRODUCTS. SOME STATES DO NOT ALLOW THE EXCLUSION OR LIMITATION OF INCIDENTAL OR CONSEQUENTIAL DAMAGES, SO THE ABOVE LIMITATION OR EXCLUSION MAY NOT APPLY TO YOU.

JET sells through distributors only. The specifications listed in JET printed materials and on official JET website are given as general information and are not binding. JET reserves the right to effect at any time, without prior notice, those alterations to parts, fittings, and accessory equipment which they may deem necessary for any reason whatsoever. JET® branded products are not sold in Canada by JPW Industries, Inc.

## Product Listing with Warranty Period

90 Days – Parts; Consumable items
1 Year – Motors; Machine Accessories
2 Year – Metalworking Machinery; Electric Hoists, Electric Hoist Accessories
5 Year – Woodworking Machinery
Limited Lifetime – JET Parallel clamps; VOLT Series Electric Hoists; Manual Hoists; Manual Hoist Accessories; Shop Tools; Warehouse & Dock products; Hand Tools; Air Tools

NOTE: JET is a division of JPW Industries, Inc. References in this document to JET also apply to JPW Industries, Inc., or any of its successors in interest to the JET brand.

# Table of Contents

Section	Page
Warranty and Service.....	2
Warnings .....	4
Introduction.....	6
Specifications.....	6
Unpacking.....	7
Contents of the Shipping Container.....	7
Set-up and Installation .....	8
Preparing the Milling Machine for Service .....	8
JTM-4VS Dimensions .....	9
JTM-4VS Overview and Terminology .....	10
Electrical Connections.....	11
General Electrical Cautions.....	11
Wire Sizes.....	11
Lubrication.....	11
Operating Instructions .....	11
Operating Controls .....	11
Motor Switch .....	11
Variable Speed Control.....	12
Spindle Brake.....	13
High-Neutral-Low Shift Lever.....	13
Quill Power Feed Lever .....	13
Feed Rate Lever.....	13
Feed Trip Cam Lever.....	14
Feed Direction Control.....	14
Coarse Feed Handle.....	14
Quill Lock Lever.....	14
Micrometer Adjusting Nut.....	14
Fine Feed Handwheel.....	14
Depth Scale and Stop.....	15
Power Feed Operation.....	15
Draw Bar Operation - Changing Tooling.....	16
Clamping Work Piece to the Table.....	16
Adjustments.....	16
Mill Head – Left/Right Adjustment .....	16
Mill Head – Fore/Aft Adjustment.....	17
Positioning the Ram .....	18
Positioning the Ram Fore and Aft.....	18
Positioning the Ram on its Turret.....	18
Gib Adjustment.....	18
Adjustment of Knee Gib .....	18
Adjustment of Saddle Gib.....	18
Adjustment of Table Gib.....	18
Power Feed Trip Lever Mechanism.....	19
Table Lead Screw Backlash Adjustment .....	19
Cross Feed Backlash Adjustment.....	19
Longitudinal Backlash Adjustment .....	19
Maintenance .....	21
Lubrication.....	21
Periodic Maintenance Requirements .....	21
Replacement of Drive Motor .....	22
Replacement of Vari-Speed Belt.....	23
Replacement of Brake Shoes, Springs and/or Timing Belt.....	23
Replacement of Quill Feed Clock Spring.....	24
Replacement Parts.....	24
Head Assembly .....	25
Parts List for Head Assembly.....	26
Spindle Assembly .....	29

Base Assembly.....	33
Parts List for Base Assembly .....	34
Lead Screw Assembly .....	36
One-Shot Lubrication System .....	37
Electrical Connections – Single Phase only.....	38
Electrical Connections – 3 Phase only .....	39

## Warnings

1. Read and understand the entire owner's manual before attempting assembly or operation.
2. Read and understand the warnings posted on the machine and in this manual. Failure to comply with all of these warnings may cause serious injury.
3. Replace the warning labels if they become obscured or removed.
4. This turret mill is designed and intended for use by properly trained and experienced personnel only. If you are not familiar with the proper and safe operation of a turret mill, do not use until proper training and knowledge have been obtained.
5. Do not use this turret mill for other than its intended use. If used for other purposes, JET, disclaims any real or implied warranty and holds itself harmless from any injury that may result from that use.
6. Always wear approved safety glasses/face shields while using this turret mill. (Everyday eyeglasses only have impact resistant lenses; they are not safety glasses.)
7. Before operating this turret mill, remove tie, rings, watches and other jewelry, and roll sleeves up past the elbows. Remove all loose clothing and confine long hair. Non-slip footwear or anti-skid floor strips are recommended. Do not wear gloves.
8. Wear ear protectors (plugs or muffs) during extended periods of operation.
9. Some dust created by power sanding, sawing, grinding, drilling and other construction activities contain chemicals known to cause cancer, birth defects or other reproductive harm. Some examples of these chemicals are:
  - Lead from lead based paint.
  - Crystalline silica from bricks, cement and other masonry products.
  - Arsenic and chromium from chemically treated lumber.

Your risk of exposure varies, depending on how often you do this type of work. To reduce your exposure to these chemicals, work in a well-ventilated area and work with approved safety equipment, such as face or dust masks that are specifically designed to filter out microscopic particles.
10. Do not operate this machine while tired or under the influence of drugs, alcohol or any medication.
11. Make certain the switch is in the OFF position before connecting the machine to the power supply.
12. Make certain the machine is properly grounded.
13. Make all machine adjustments or maintenance with the machine unplugged from the power source.
14. Remove adjusting keys and wrenches. Form a habit of checking to see that keys and adjusting wrenches are removed from the machine before turning it on.
15. Keep safety guards in place at all times when the machine is in use. If removed for maintenance purposes, use extreme caution and replace the guards immediately.
16. Some coolants used for machining contain chemicals that may be hazardous to your health if not used properly. Read and understand all information on the coolant container and protect yourself accordingly.



# Warnings

17. Check damaged parts. Before further use of the machine, a guard or other part that is damaged should be carefully checked to determine that it will operate properly and perform its intended function. Check for alignment of moving parts, binding of moving parts, breakage of parts, mounting and any other conditions that may affect its operation. A guard or other part that is damaged should be properly repaired or replaced.
18. Provide for adequate space surrounding work area and non-glare, overhead lighting.
19. Keep the floor around the machine clean and free of scrap material, oil and grease.
20. Keep visitors a safe distance from the work area. Keep children away.
21. Give your work undivided attention. Looking around, carrying on a conversation and “horse-play” are careless acts that can result in serious injury.
22. Maintain a balanced stance at all times so that you do not fall or lean against the cutters or other moving parts. Do not overreach or use excessive force to perform any machine operation.
23. Use the right tool at the correct speed and feed rate. Do not force a tool or attachment to do a job for which it was not designed. The right tool will do the job better and more safely.
24. Use recommended accessories; improper accessories may be hazardous.
25. Maintain tools with care. Keep cutters sharp and clean for the best and safest performance. Follow instructions for lubricating and changing accessories.
26. Turn off the machine and disconnect from power before cleaning. Use a brush or compressed air to remove chips or debris — do not use your hands.
27. Do not stand on the machine. Serious injury could occur if the machine tips over.
28. Never leave the machine running unattended. Turn the power off and do not leave the machine until it comes to a complete stop.
29. Remove loose items and unnecessary work pieces from the area before starting the machine.

## Familiarize yourself with the following safety notices used in this manual:



This means that if precautions are not heeded, it may result in minor injury and/or possible machine damage.



This means that if precautions are not heeded, it may result in serious or even fatal injury.

# Introduction

This manual is provided by JET, covering the safe operation and maintenance procedures for a JET Model JTM-4VS Turret Milling Machine. This manual contains instructions on installation, safety precautions, general operating procedures, maintenance instructions and parts breakdown. This machine has been designed and constructed to provide consistent, long-term operation if used in accordance with instructions set forth in this manual. If there are any questions or comments, please contact either your local supplier or JET. JET can also be reached at our web site: [www.jettools.com](http://www.jettools.com).

# Specifications

Model Number .....	JTM-4VS-1 .....	JTM-4VS-3
Stock Number .....	<b>690180</b> .....	<b>690182</b>
Spindle Taper .....	R-8 .....	R-8
Diameter of Quill (in.) .....	3.375 .....	3.375
Number of Spindle Speeds.....	Variable .....	Variable
Range of Spindle Speeds (RPM).....	60 to 4200 .....	60 to 4200
Downfeeds per Revolution of Spindle (in.) .....	0.0015, 0.003, 0.006 .....	0.0015, 0.003, 0.006
Spindle Travel (in.).....	5 .....	5
Head Movement – Left and Right (deg.).....	90 .....	90
Head Movement – Fore and Aft (deg.).....	45 .....	45
Maximum Distance Spindle to Table (in.).....	17-1/2 .....	17-1/2
Maximum Distance Spindle to Column (in.) .....	19 .....	19
Minimum Distance Spindle to Column (in.) .....	4-1/2 .....	4-1/2
Collet Capacity (in.).....	1/8 – 7/8 .....	1/8 – 7/8
Table Size (in.).....	9 x 49 .....	9 x 49
Longitudinal Table Travel, maximum (in.) .....	34 .....	34
Table Cross Travel, maximum (in.).....	12 .....	12
Number of T-Slots .....	3 .....	3
T-Slot Size (WxD)(in.) .....	5/8 x 3/4 .....	5/8 x 3/4
T-Slot Centers (in.).....	2-1/2 .....	2-1/2
Table Load, maximum (lbs.) .....	660 .....	660
Knee Travel, maximum (in.) .....	14-1/2 .....	14-1/2
Ram Travel, maximum (in.) .....	13-3/8 .....	13-3/8
Overall Dimensions (in.) .....	66W x 63D x 85H .....	66W x 63D x 85H
Motor .....	TEFC 2HP, 1PH, 115/230V, 60Hz .....	TEFC 3 HP, 3PH, 230/460V, 60Hz (rewired 230V) (rewired 230V)
Net Weight, approx. (lbs.).....	2,420 .....	2,420

The above specifications were current at the time this manual was published, but because of our policy of continuous improvement, JET reserves the right to change specifications at any time and without prior notice, without incurring obligations.

# Unpacking

Open shipping container and check for shipping damage. Report any damage immediately to your distributor and shipping agent. Do not discard any shipping material until the Turret Mill is assembled and running properly.

Compare the contents of your container with the following parts list to make sure all parts are intact. Missing parts, if any, should be reported to your distributor. Read the instruction manual thoroughly for assembly, maintenance and safety instructions.

## Contents of the Shipping Container

*Note: Some parts may be pre-installed on the mill.*

- 1 Turret Mill (not shown)
- 1 Flat Way Cover
- 1 Pleated Way Cover
- 1 Draw Bar

- 3 Table Adjustment Handles
- 1 Tool Box, containing:
  - 1 Hex Key Set (1.5-10mm) \*
  - 1 17/19mm Box Wrench \*
  - 1 Cross Point Screw Driver #2 \*
  - 1 Flat Blade Screw Driver #2 \*
  - 1 Plastic Oil Bottle \*
  - 1 Elevating Crank Handle
  - 1 Handwheel
  - 1 Coarse Feed Handle
  - 1 Can White Touch Up Paint
  - 1 Eye Bolt
  - 1 Operator's Manual (not shown)
  - 1 Warranty Card (not shown)

*\* parts with an asterisk are also included in the tool box service kit, p/n JTM4VS-TB.*



Figure 1

### **⚠ WARNING**

**Read and understand the entire contents of this manual before attempting set-up or operation! Failure to comply may cause serious injury.**

If your mill is supplied with an optional Table Powerfeed and/or DRO, be sure to consult the separate instruction materials that accompany them.

# Set-up and Installation

## Preparing the Milling Machine for Service

1. Remove any crating which may be covering the machine on the pallet.
2. Remove accessory items from the pallet or machine table. Compare these items with the list on the previous page.
3. Check the tightness of the lifting ring on the ram to be certain it is tight.
4. Check the tightness of the lock handles on the ram (see Figure 23) to be certain the ram is locked tight.
5. Remove the nuts and/or bolts, which secure the machine to the pallet.
6. Center an overhead crane or other suitable overhead lifting device and sling arrangement over the lifting ring.

**Note:** This machine weighs over 2400 pounds! Be certain the lifting arrangement is new or in excellent condition and has a safety factor that will account for age, difficulties in lifting, etc. When lifting using the ring, the machine will tip forward. If you wish, you can minimize this tipping by rigging a support sling over the front of the machine. Be careful when doing this, to prevent the sling from damaging any components on the front of the machine. Be sure to steady the mill to prevent it from spinning.

7. Lift the machine off the pallet no higher than necessary to clear the hold-down hardware, then pull the pallet out of the way. Do NOT get hands or feet underneath the machine when removing the pallet!
8. Put the machine base over the hold-down system where the machine will be spotted. Anchor bolts of sufficient size and length must be fastened to the floor according to the footprint of the mill. See diagram on page 10.

**Note:** The accompanying diagrams show you the maximum dimensions of the machines with the table, ram, etc., fully extended in all possible directions. When spotting the machine be certain to leave room not only for the machine itself, but also for operator clearance and clearance for workers servicing the machine, and any unusual sizes of workpieces that might extend off the machine's table.

9. When the machine is over its anchors, level the machine using shims under the corners needing them. The machinist's level used for leveling should be placed on the table. The table is the reference surface for both side-to-side and fore-

and-aft leveling. Be certain you get it level in BOTH directions.

### **CAUTION**

Mill must be supported equally under all four corners. Failure to comply may cause the column to twist and put a bind in the table ways.

10. When the machine is level, secure the base to the anchor system.

**IMPORTANT:** Before attempting to raise the mill head, refer to Mill Head – Left/Right Adjustment in the *Adjustments* section for procedures to safely raise and set up the mill head.

11. Loosen the four hex head nuts (see A, Figure 22) about 1/4 turn each (counterclockwise), just enough to allow rotation of the head.
12. While assisting the worm mechanism by putting upward pressure on the motor by hand, use the wrench supplied with the machine to turn the worm nut and raise the head to upright position.
13. Tighten the headbolts slightly — not torqued — just snug.
14. Using mineral spirits or other cleaning solvent, clean all of the rust proofing from where it may have been applied. This is important; moving the table or any other components before removing the rust proofing will only put rust proofing where you don't want it.

*Some of the following steps may have already been performed on the machine. If so, ignore the instructions related to those particular steps. Otherwise, perform them in the order listed, referring to Figure 11 for any clarification.*

15. Install the table traverse and cross-feed cranks on their respective shafts using the nuts on the shafts to secure the cranks.
16. Remove any rust proofing from the drawbar and its washer, and put the drawbar with washer installed into the spindle center through the top of the machine.
17. Slide the fine feed handwheel over the handwheel hub and push it back until its rollpin engages the hole in the hub and the wheel is flush with the hub surface.
18. Put the coarse feed handle on the feed shaft and tap it lightly until its roll pin engages a hole in the hub and it is flush against the hub surface.
19. Unwrap and clean the knee crank and install it on its shaft.
20. Install the rubber way covers at front and behind the table.



# JTM-4VS Dimensions

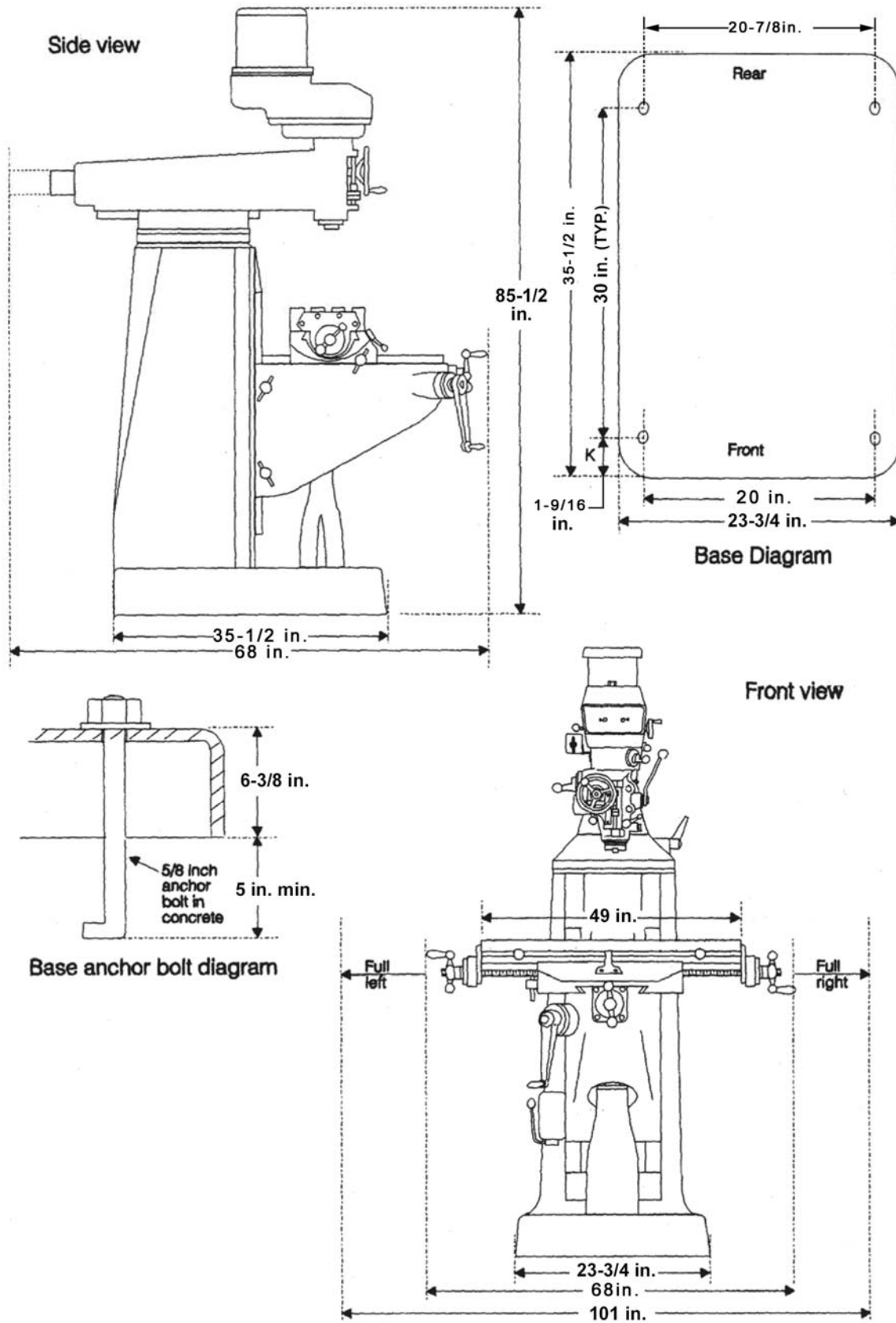

Figure 2: Installation Diagram

# JTM-4VS Overview and Terminology

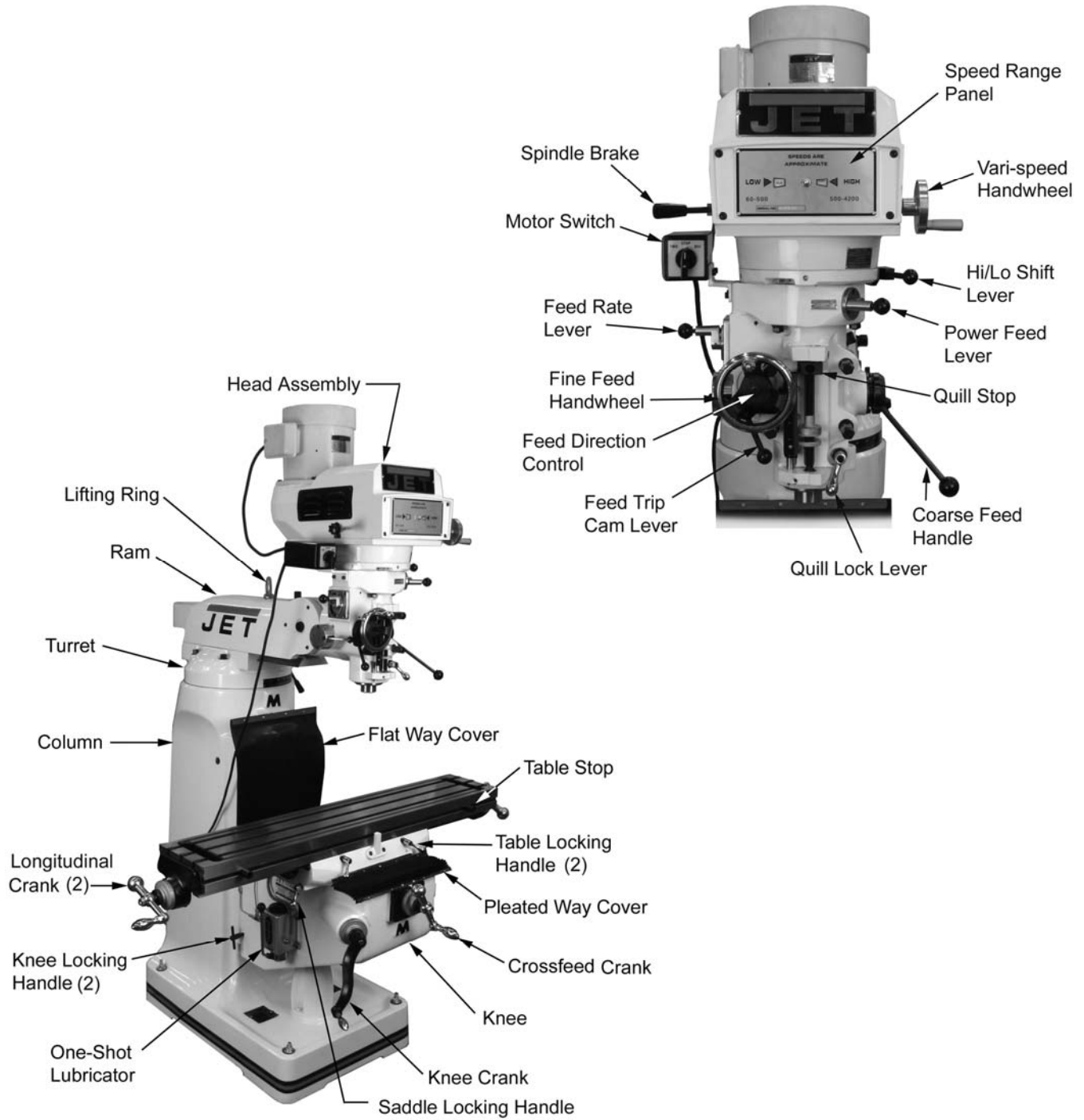

Figure 3: Overview

# Electrical Connections

**⚠WARNING** All electrical connections must be made by a qualified electrician! Failure to comply may cause serious injury!

## General Electrical Cautions

This machine must be grounded in accordance with the National Electrical Code and local codes and ordinances. This work should be done by a qualified electrician. The machine must be grounded to protect the user from electrical shock.

## Wire Sizes

**⚠CAUTION** For circuits which are far away from the electrical service box, the wire size must be increased in order to deliver ample voltage to the motor. To minimize power losses and to prevent motor overheating and burnout, the use of wire sizes for branch circuits or electrical extension cords according to the following table is recommended:

Conductor Length	AWG Number	
	230/460 Volt Lines	120 Volt Lines
0 – 50 Ft.	No. 14	No. 14
50 – 100 Ft.	No. 14	No. 12
Over 100 Ft.	No. 12	No. 8

Figure 4

Confirm that power at the site matches power requirements of the mill before connecting to the power source.

The JTM-4VS has been pre-wired for 230 volt operation. To change from 230V to the other voltage offered, remove the junction box cover on the motor and change the wires according to the diagram found on the inside of the cover.

Before connecting to the power source, make sure that the switch is in the off position.

The mill must be properly grounded.

Check for proper spindle rotation **in the high-speed range**. The spindle should rotate clockwise when viewed from the top of the machine. If the spindle rotates counter-clockwise, disconnect from power and switch two of the three power leads.

## Lubrication

**⚠CAUTION** Do not operate the mill before lubricating the machine fully. Failure to comply may cause damage to the machine.

Refer to the *Maintenance/Lubrication* section and make sure the machine has been fully lubricated before operating.

# Operating Instructions

## Operating Controls

The lubrication system is a manually operated, one-shot system requiring operator intervention. The operator must lower the one-shot lever to lubricate the machine ways and ball screws. The one-shot lubrication system reservoir is located on the left side of the machine.

The position of the milling machine mill head can be set up to accommodate the work piece being machined. The mill head can be set up for angles to the left or right and for fore and aft angles. The mill head can also be rotated on its turret. The ram can be moved back and forth to reach work piece locations at the fore and aft extremes of worktable travel. Refer to the *Adjustments* section.

## Motor Switch

The *Motor Switch* is on the upper left-hand side of the mill head (Figure 5). The switch has three positions: FWD (forward), STOP, and REV (reverse).

Setting the switch to FWD will provide clockwise spindle rotation. Use FWD for normal, right-hand tooling.

FWD (clockwise) operation occurs only when the gearbox is in the low speed position. When the gearbox is in high-speed position, the motor switch must be in the REV position to provide right-hand or clockwise rotation. Refer to Figure 6 for a chart of required switch positions.

The motor switch controls a three-phase motor. The motor can be switched from FWD to REV and back with the motor running, and will reverse direction when the switch setting is changed. At higher speeds, this may put strain on the timing belt but there will be no damage to the motor or gear mechanism.



Figure 5

## Control Positions for Milling and Drilling Operations

Control \ Action	High/low lever	Quill feed lever	Feed trip cam lever	Quill feed select lever	Feed direction control	Motor switch*
High spindle speeds						REV
Low spindle speeds						FWD
High spindle speeds with automatic downfeed				Select feed rate		REV
Low spindle speeds with automatic downfeed				Select feed rate		FWD
High spindle speeds with automatic upfeed				Select feed rate		REV
Low spindle speeds with automatic upfeed				Select feed rate		FWD
Lever feed						
Fine feed using handwheel						
Free-turning spindle for positioning or working with tooling						

### Speeds at Specific Control Settings

Hi/low speed control lever	Range of speeds using control wheel
	60 - 500 RPM
	500 - 4,200 RPM

\* Motor switch position is for right-hand tooling (tooling which requires clockwise rotation of the spindle.) If you are using left-hand tooling, simply change the motor switch to the opposite setting.

Figure 6

### Variable Speed Control

**CAUTION** Change speed only while the spindle is turning.

The vari-speed handwheel (A, Figure 7) is used to control the spindle speed. The speeds for high and low speed ranges are displayed on the panel on the front of the mill head (B, Figure 7).

All speed changes must be made while the motor is running. Attempting speed changes without the motor running can result in damage to the drive mechanism.

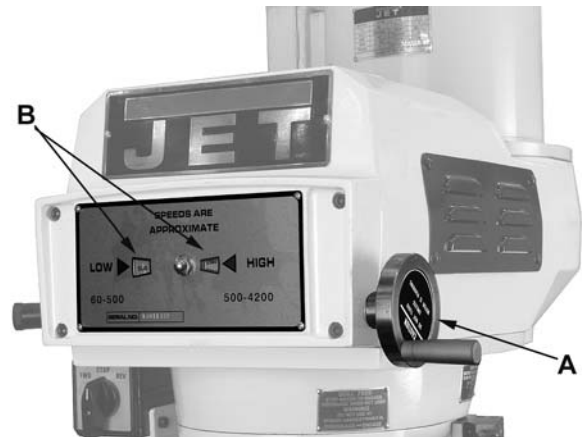

Figure 7

## Spindle Brake

The spindle brake lever is located on the upper left side of the mill head (Figure 8). Pull lever downward to apply the brake. The spindle brake lever is used only after the motor switch has been set to OFF. The spindle will not stop with the motor running.



Figure 8

## High-Neutral-Low Shift Lever

The mill head can be driven directly (High Speed) or through the back gear (Low Speed) in the mill head. The selection is made by changing the position of the shift lever.

The *shift lever* is located at the lower right side of the mill head (Figure 9). The lever position closest to the operator is the *High* setting. The lever position away from the operator is the *Low* setting. The middle position is the *Neutral* setting.

**CAUTION** Do not shift the High-Low Gear Lever while the motor is running. Rotate the spindle by hand to facilitate changing lever positions.



Figure 9

## Quill Power Feed Lever

**CAUTION** Do not use power feed at speeds above 3000 R.P.M.

**CAUTION** It is recommended to disengage the power feed worm gear whenever the power feed is not required. This avoids unnecessary wear on the worm gear.

**CAUTION** Do not move the Quill Power Feed Lever unless the motor is at a complete stop. When changing the lever position, do it gently. If the gear does not engage, jog the motor and allow it to stop before attempting to change.

The quill power feed lever is located on the right side of the mill head (Figure 10). It is used to engage and disengage the quill power feed mechanism.

The power feed is engaged by pulling out the knob and rotating the handle to a new locked position. When engaged, the power feed mechanism will drive the spindle upward or downward. The power feed mechanism will not drive the spindle when the handle is in the disengagement position.

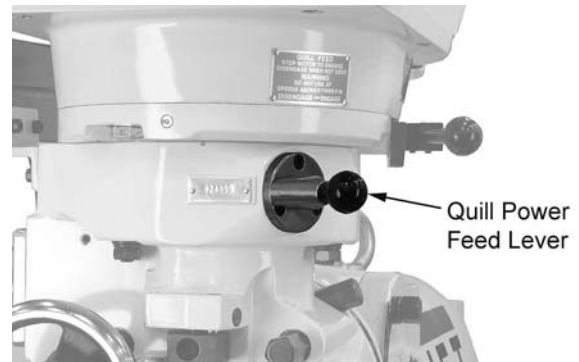

Figure 10

## Feed Rate Lever

The *Feed Rate Lever* (Figure 11) is used to set the per-revolution rate of the power feed mechanism. Three feed rates are available: 0.0015-inch, 0.003-inch, and 0.006-inch per revolution. The positions are shown on an indicator plate under the feed rate lever.

The rate is selected by pulling out the knob on the feed rate lever and moving the handle to the detent of the desired feed rate.

**Note:** The knob is spring loaded – pull out to rotate to new position.

Unlike other controls on the machine, the lever shifts into engagement more easily with the motor running, and the quill feed lever engaged.

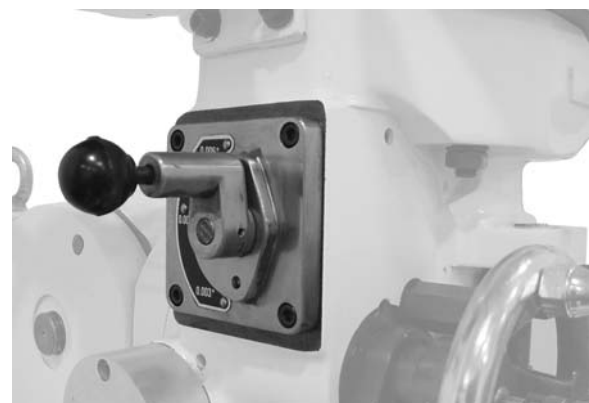

Figure 11

## Feed Trip Cam Lever

The *Feed Trip Cam Lever* (A, Figure 12) is located on the left side of the head behind the *Manual Fine Feed Handwheel* (B, Figure 12). It engages the overload clutch on the pinion shaft when positioned to the left. The *Feed Trip Cam Lever* stays engaged until *Quill Stop* (C, Figure 15) comes in contact with *Micrometer Adjusting Nut* (A, Figure 15) forcing it to drop out automatically, or until it is released manually by engaging the lever to the right.

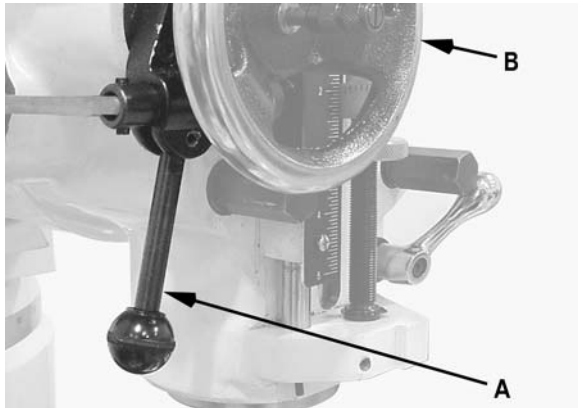

Figure 12

## Feed Direction Control

The *Feed Direction Control* (B, Figure 13) determines whether the power feed will move up, down, or not move at all. The position of the knob depends upon the direction of spindle rotation (see the *Motor Switch* section). The position of the control may be changed with the system stopped or running. If the control does not engage easily, move the fine feed handwheel (A, Figure 13) back and forth to aid engagement.

If the spindle is rotating clockwise, *in* is downfeed; *out* is upfeed. If the spindle rotation is counterclockwise, *out* is downfeed; *in* is upfeed. Neutral position is between the *in* and *out* position.

**CAUTION** It is recommended that the Feed Direction Knob be left in the neutral position when not in use.

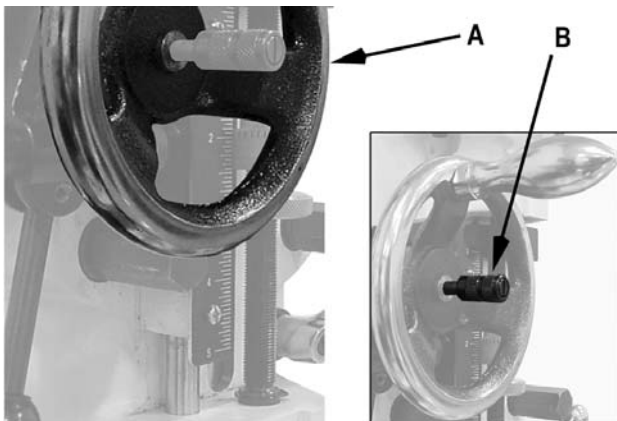

Figure 13

## Coarse Feed Handle

The *Coarse Feed Handle* (A, Figure 14) is located on the right side of head. The *Coarse Feed Handle* is used for non-precision drilling operations and for moving the quill to a specific depth. A return spring will retract the spindle automatically once the handle is released.

## Quill Lock Lever

The *Quill Lock Lever* (B, Figure 14) is located on the right side of the head. Rotate the handle clockwise to lock the quill in a desired position. Rotate the handle counter-clockwise to release.

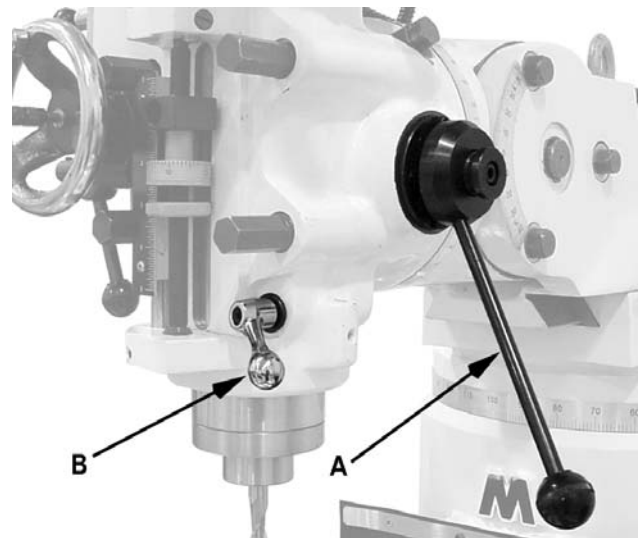

Figure 14

## Micrometer Adjusting Nut

The *Micrometer Adjusting Nut* (A, Figure 15) is located on the front of the head. Use for setting specific spindle depth. Secure with the *lock nut* (B, Figure 15).

## Fine Feed Handwheel

When the controls are set for the *Fine feed using Handwheel* position (see Figure 6), the *Fine Feed Handwheel* (A, Figure 13) can be used for manual fine feed control in either upward or downward direction of the quill.

**WARNING** Remove the Manual Fine Feed Handwheel when not in use. Failure to comply may cause serious injury.

## Depth Scale and Stop

Referring to Figure 15:

The *Depth Scale and Stop* are used in drilling operations to set the depth of the drilled hole. The depth scale is located on the front of the mill head. The scale consists of a *Micrometer Adjusting Nut* (A), *Lock Nut* (B), *Quill Stop* (C), *Quill Stop Screw* (D), and *Scale* (E).

The *Micrometer Adjusting Nut* is set to the desired dimension and locked in place using the *Lock Nut*. The quill stop provides a positive stop for quill travel.

The graduations on the micrometer nut are in 0.001-inch increments. Adjustment of quill travel is made by rotating the micrometer nut.

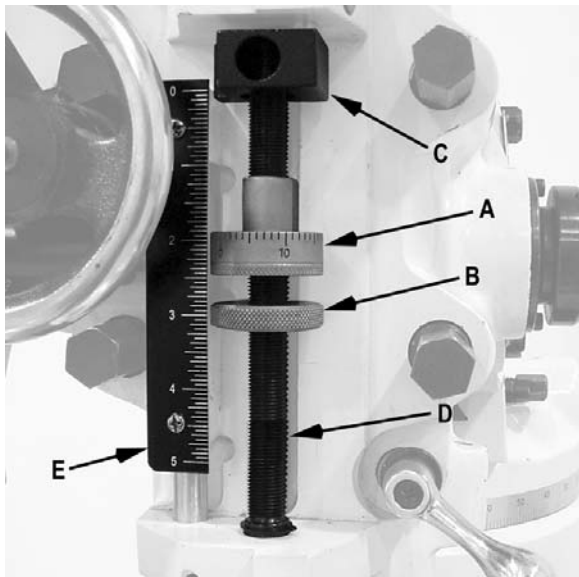

Figure 15

## Power Feed Operation

The *Feed Trip Adjustment* sets the point at which the quill will reset during *Power Feed*.

Referring to Figure 17:

**⚠ WARNING** Be sure that the **Manual Fine Feed Handwheel** is removed. Failure to comply may cause serious injury.

1. Loosen the Locknut (I).
2. With the *Quill Feed Handle* (J), advance the quill to the point where the feed should stop.
3. Engage the *Feed Trip Cam Lever* (D) by pulling away from head assembly.
4. Adjust *Micrometer Adjusting Nut* (H) against *Quill Stop* (G).
5. Continue turning the *Micrometer Adjusting Nut* (H) until the *Feed Trip Cam Lever* (D) trips.
6. Tighten the *Locknut* (I).
7. Ensure *Quill Lock* (K) is disengaged by rotating counter-clockwise.
8. Start the spindle (A):

9. Select feed rate with the *Variable Speed Control Handwheel* (E).
10. Set the *Feed Rate Lever* (B) to the feed rate required for the tooling and material required.
11. Place the *Quill Feed Engagement Lever* (F) in the *Engaged* position.
12. Select feed direction by setting the *Feed Direction Knob* (C) position per the table:

Spindle Dir.	Feed Dir.	Knob Pos.
CW	Down	In
	Up	Out
CCW	Down	Out
	Up	In

Figure 16

13. Engage the *Feed Trip Cam Lever* (D) by pulling away from head assembly.

**Note:** Due to variables in tool diameter, coatings, coolant, and materials, no specific spindle speed or feed rate recommendations are provided. Use general shop manuals that have data applicable to the milling and drilling operations being performed. Or, contact the supplier of the tooling, coolant, and material for specific recommendations.

**IMPORTANT:** The power feed can be used for drills up to 3/8" in diameter (mild steel). Use manual feed for drills larger than 3/8".

**⚠ CAUTION** The overload clutch is factory set to hold up to 200 lbs. downfeed pressure on the quill (accommodates drills up to 3/8"). Do not attempt to adjust clutch pressure.

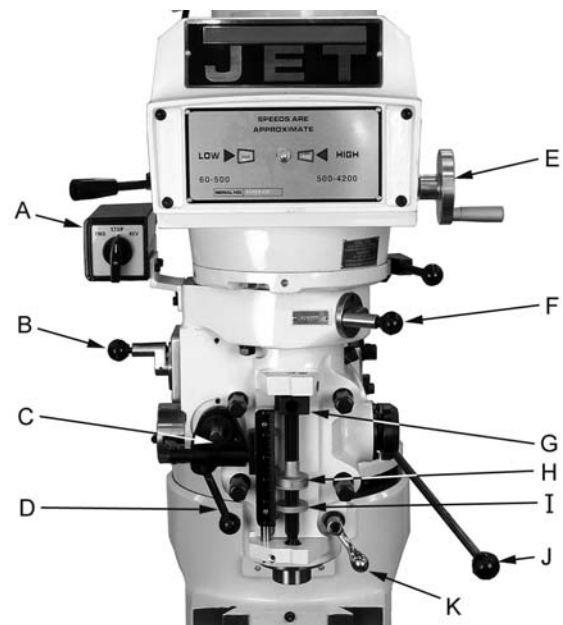

Figure 17

## Draw Bar Operation - Changing Tooling

1. Using the wrench provided with the machine, loosen the draw bar two or three turns (turn counterclockwise) using the draw bar hex (Figure 18).

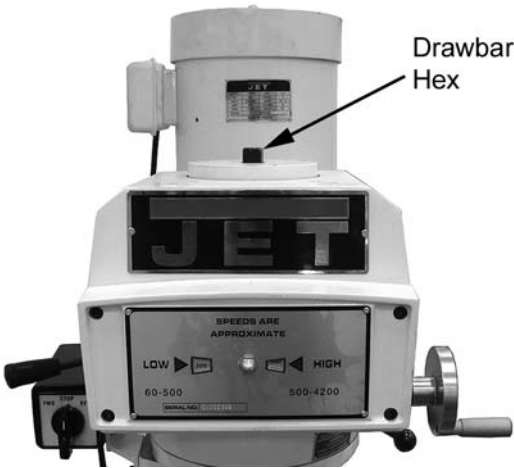
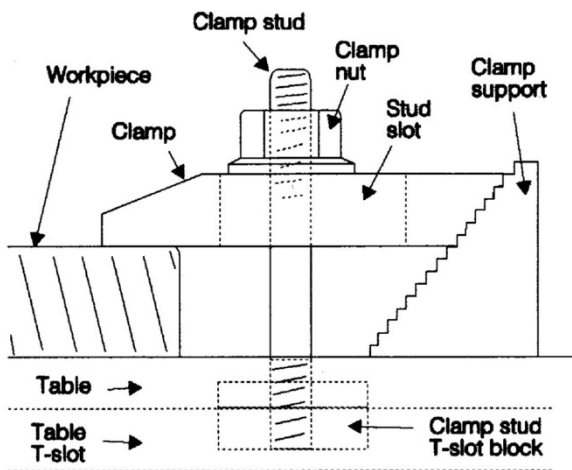

Figure 18

2. Tap the top of the draw bar with a soft-faced hammer to loosen the collet from the taper.
3. Remove the tool from the collet.
4. Insert the tool you are going to use into the collet.
5. Tighten the draw bar firmly using the wrench provided with the machine. Turn the draw bar. The tool is now ready for use.

## Clamping Work Piece to the Table

1. The worktable has 5/8-inch T-slots for clamping the work piece to the table.
2. Set motor switch to STOP position.
3. Place the work piece on the table.
4. Clamp the work piece using the T-slot clamps, studs, and step blocks as required (Figure 19).



Typical T-Slot Clamp Setup

Figure 19

## Adjustments

### Mill Head – Left/Right Adjustment

**WARNING** Make sure the machine base is secured to the floor before repositioning the mill head. The center of gravity can shift enough to cause the machine to tip over, resulting in serious injury to the operator and damage to the machine.

1. Loosen four large hex nuts that secure the mill head to the ram adapter (refer to Figure 20).  
1/4 turn should be sufficient to allow the head to move.

**NOTE:** For angles greater than 10 degrees, use your free hand to support the mill head, taking some weight off the brass worm gears. Doing so will greatly lengthen the life of the worm gears.

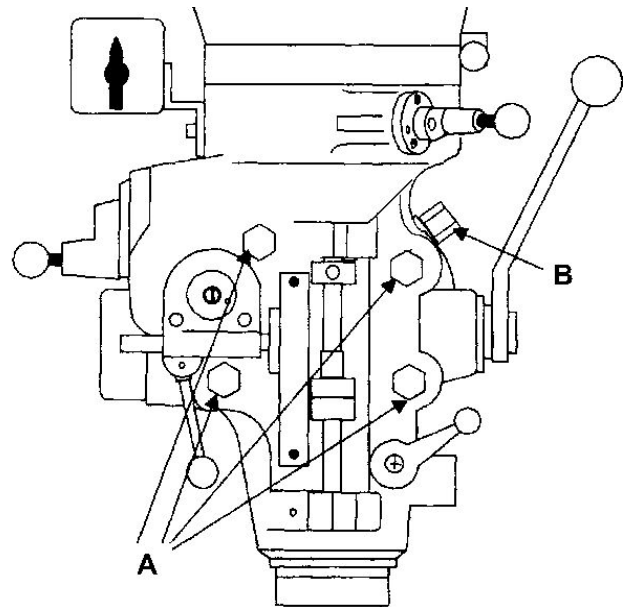

Figure 20

2. Turn the worm nut (B, Figure 20) to tilt the head left or right as required. Use the scale on the ram adapter to set the desired angle.

**Note:** The scales on the ram adapter and for head rotation are guides only. Close tolerance work will require the use of a dial indicator to make sure the head is 90° to the table in the X and Y axis. Please note the table is fitted to be slightly higher in front, usually about 0.0005”.

**CAUTION** Be sure to apply torque in two steps using a crossing pattern. Failure to do so could distort the face of the ram adapter.

3. Tighten the four hex nuts. Tighten in two steps using a calibrated torque wrench. Use a crossing pattern to tighten the nuts. Tighten initially to 25 foot-pounds.



4. Before applying final torque, check to make sure the mill head is perpendicular to the worktable.
5. Set up a dial indicator in a collet and secure using the draw bar (refer to Figure 22).
6. Put the spindle drive in neutral.
7. Set the dial indicator plunger on the worktable. Zero the indicator.
8. Rotate the spindle 180 degrees (when rotating, raise the dial indicator plunger by hand to prevent it from dropping into the table T-slots).
9. Read the dial indicator. The indicator should read zero. If not, loosen the four hex nuts and reposition the mill head.
10. Recheck perpendicularity using the dial indicator. Repeat the procedure above until the dial indicator reads zero in both positions.

**CAUTION** Be sure to apply torque in two steps using a crossing pattern. Failure to do so could distort the face of the ram adapter.

11. Tighten the four hex nuts. Tighten in two steps using a calibrated torque wrench. Use a crossing pattern to tighten the nuts. Tighten initially to 25 foot-pounds, then tighten to a final torque of 50 foot-pounds.

### Mill Head – Fore/Aft Adjustment

1. Setting the angle:
  - a. Loosen the three ram adapter clamp bolts on the ram (A, Figure 21). There is no need to loosen the bolts more than 1/2 turn to allow tilting.

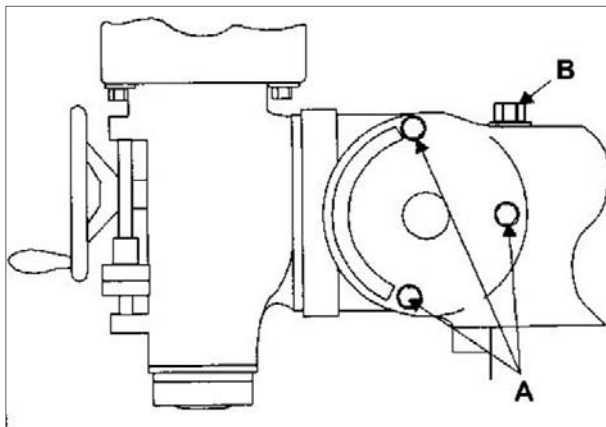

Figure 21

- b. Support the mill head with your free hand. Press upward on the spindle when changing the angle.
- c. Turn the ram adapter worm nut (B, Figure 21) to tilt the head forward and backward. Use the scale on the ram adapter to locate the desired angle.

2. Returning to upright position:
  - a. When returning the mill head to its full upright position, be sure to support the head by upward pressure on the spindle as you turn the worm nut.
  - b. Check to make sure the mill head is perpendicular to the worktable.
  - c. Set up a dial indicator in a collet and secure using the draw bar (refer to Figure 22).

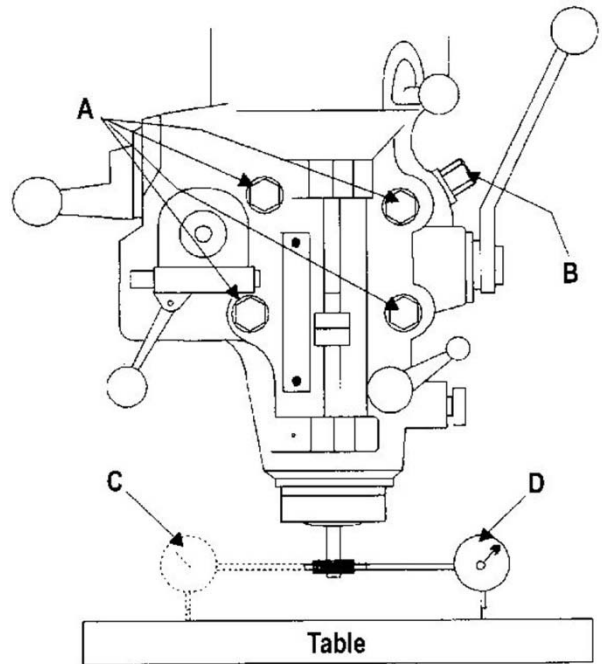

Figure 22

- d. Put the spindle drive in neutral.
- e. Set the dial indicator plunger on the worktable. Zero the indicator.
- f. Rotate the spindle 180 degrees (when rotating, raise the dial indicator plunger by hand to prevent it from dropping into the table T-slots).
- g. Read the dial indicator. The indicator should read zero. If not, loosen the four hex nuts and reposition the mill head.
- h. Recheck perpendicularity using the dial indicator. Repeat the procedure above until the dial indicator reads zero in both positions.
- i. When the indicator reads zero, tighten the ram adapter clamp bolts.

## Positioning the Ram

### Positioning the Ram Fore and Aft

1. Loosen the two bolts (A, Figure 23) that lock the ram to its ways.

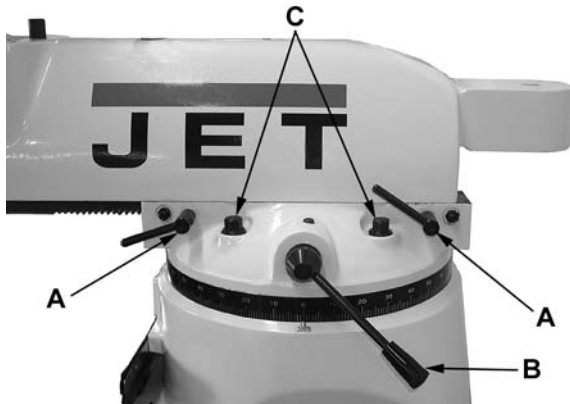

Figure 23

2. Turn the lever (B, Figure 23) to move the ram on its ways.
3. When the desired position is reached, lock the bolts (A, Figure 23) securely.

### Positioning the Ram on its Turret

**⚠WARNING** Make sure the machine base is secured to the floor before repositioning the ram. The center of gravity can shift enough to cause the machine to tip over, resulting in serious injury to the operator and damage to the machine.

1. Loosen four turret lock bolts (C, Figure 23) that clamp the ram to the top of the base. 1/2 turn should be sufficient to allow the turret to move.

**Note:** Use gentle hand pressure to avoid rapid movement.

2. Turn the ram until the spindle is in the desired position. Use the scale on the turret for degree measurement.
3. Tighten the four turret lock bolts (C, Figure 23).

## Gib Adjustment

The table, saddle and knee are equipped with adjustable gibs. The gibs may require adjustment if unusual vibration is noted when the locking mechanisms are off, or if you experience unusual vibration when spindle speed, tooth pitch or depth of cut do not account for the vibration.

**NOTE:** When adjusting gibs, always start with the knee first; adjust the saddle second, and adjust the table last.



Figure 24

### Adjustment of Knee Gib

The knee gib adjustment screw (A, Figure 24) is located under the chip wiper at the rear of the knee where it contacts the column. Remove the way cover and the wiper to expose the gib adjustment screw. Tighten the screw until a slight drag is felt when turning the knee crank.

### Adjustment of Saddle Gib

The saddle gib adjustment screw is on the left front of the saddle (B, Figure 24). Tighten the screw until a slight drag is felt when turning the cross-feed crank.

### Adjustment of Table Gib

The table gib adjustment screw (C, Figure 24) is on the left-hand side, beneath the table. Tighten the screw until a slight drag is felt when turning the longitudinal table cranks.

## Power Feed Trip Lever Mechanism

Refer to Figure 25.

The power feed trip lever mechanism will need to be adjusted if worn or whenever any trip lever mechanism components are replaced.

1. Loosen the feed trip adjusting screw lock nut.
2. Loosen the adjusting screw until it is loose in the lever and no longer contacts the bottom of the feed trip plunger.
3. Using the coarse feed handle, move the quill to the bottom of its travel so the quill stop contacts the micrometer nut. Hold the quill on the stop.
4. Pull the feed handle out to engage the power feed system.
5. Turn the feed trip adjusting screw until the power feed disengages.
6. Tighten the feed trip adjusting screw.
7. Release the quill stop so you can engage the power feed mechanism using the power feed trip lever.
8. Using the coarse feed handle, pull the quill stop back into firm contact with the micrometer nut.

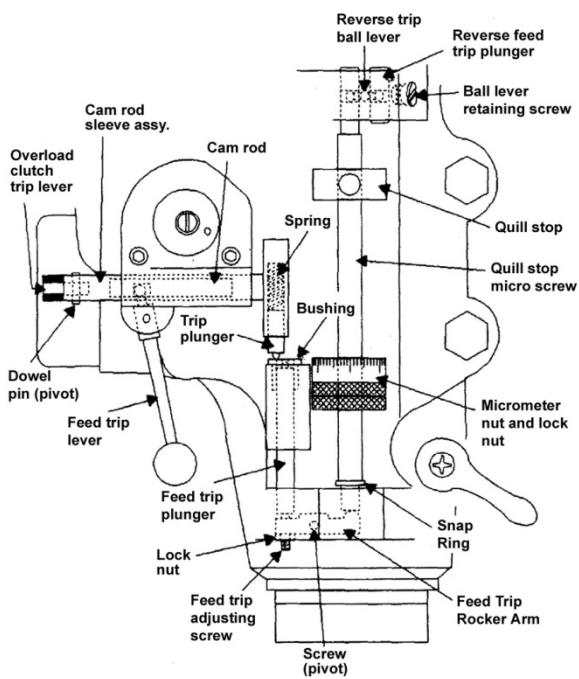

Figure 25

**Note:** The power feed should disengage when the quill stop pushes on the micrometer nut. If it does not disengage, repeat the adjustment steps above.

9. Engage the power feed and move the quill stop to the top of its travel. Make sure that the reverse trip mechanism also disengages the

power feed. If not, readjust the mechanism until positive disengagement occurs when the quill is at the top of its stroke.

10. Check for correct operation using the coarse feed handle. If operating correctly, start the drive motor and engage the power feed mechanism. Verify that the power feed lever correctly engages and disengages when driven by the drive motor.

## Table Lead Screw Backlash Adjustment

Refer to Figure 26.

The milling machine table is moved by a lead screw and nut for each machine axis. For proper operation, there must be clearance between the lead screw and the nut, which results in backlash. A second lead screw nut is provided to eliminate most of the backlash. The following procedures provide instructions for obtaining acceptable backlash.

### Cross Feed Backlash Adjustment

1. Use the cross feed crank to move the table to the extreme rear of its travel.
2. Remove the pleated way cover.
3. Open the two chip guards enough to expose the cross-feed adjustment nut (the nut that is toward the rear of the nut bracket is not adjustable – only the front nut is adjustable).
4. Loosen the two nut locking screws.
5. Turn the nut slightly to tighten it against the opposing nut.
6. Tighten the two nut locking screws.
7. Using the cross-feed crank, move the table to the middle position.
8. Set up a dial indicator to check cross-feed backlash. Gently move the cross feed crank back and forth while watching the dial indicator. Backlash should be between 0.003 inch and 0.005 inch.
9. If necessary, repeat the steps above to set backlash.
10. Install the pleated way cover.

### Longitudinal Backlash Adjustment

Refer to Figure 26.

1. Only one of the longitudinal lead screw nuts can be adjusted. The other nut is fixed. The left hand nut is typically adjustable. This can be determined by looking at the nut from the underside of the table.
2. Loosen the two nut locking screws.
3. Turn the nut slightly to tighten it against the opposing nut.

4. Tighten the two nut locking screws.
5. Using the longitudinal table crank, move the table to the middle position.
6. Set up a dial indicator to check longitudinal backlash. Gently move the crank back and forth while watching the dial indicator. The backlash should be between 0.003 inch and 0.005 inch.

If necessary, repeat the steps above to set backlash.

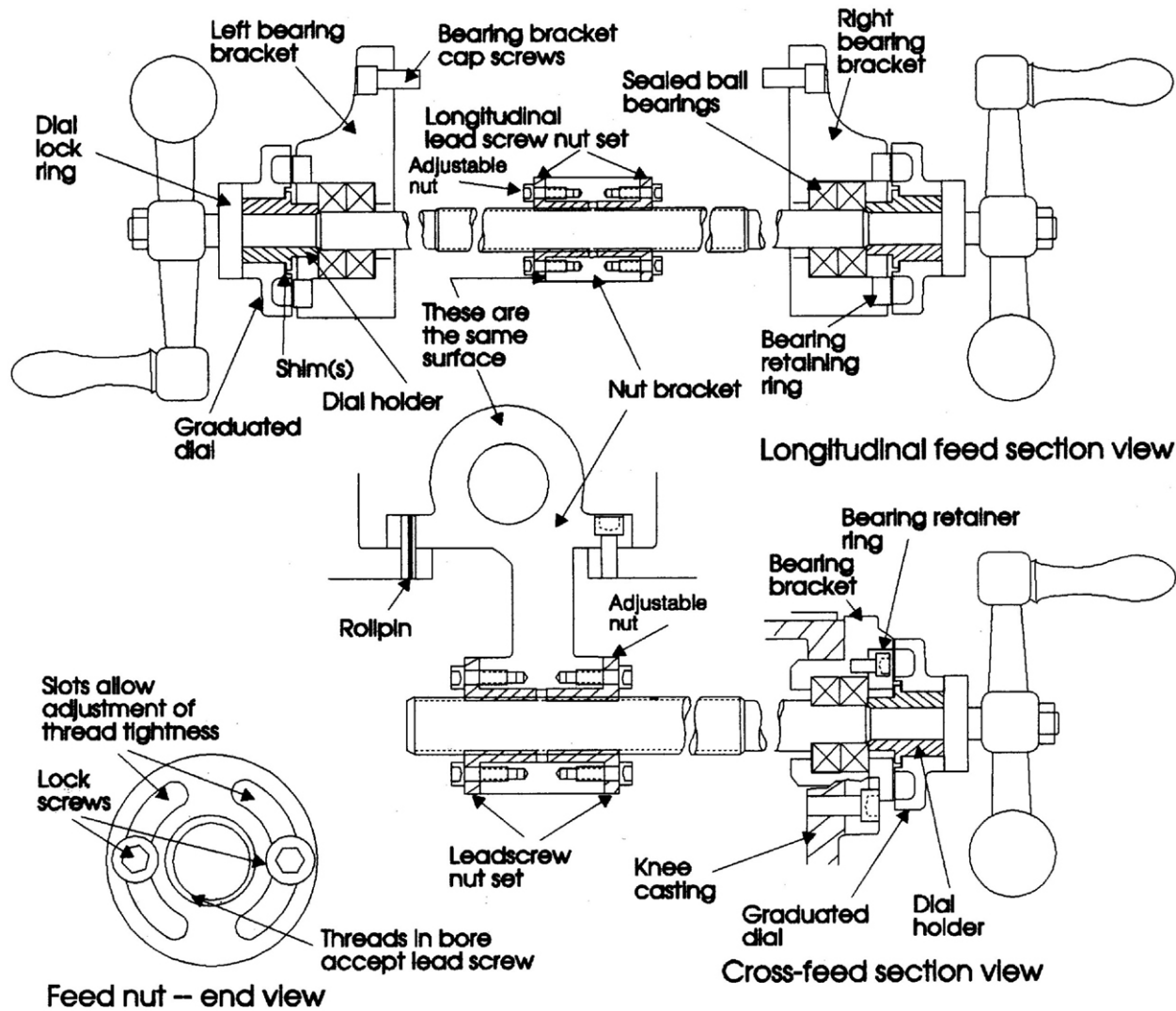

## Table Lead Screw Components

Figure 26

# Maintenance

**⚠WARNING** Before any intervention on the machine, disconnect it from the electrical supply by pulling out the plug or switching off the main switch! Failure to comply may cause serious injury.

## Lubrication

The milling machine is equipped with a “one-shot” lubrication system. The system lubricates the lead screws and ways. An oil cup and grease nipple on the mill head provide lubrication for the spindle bearings and back gear mechanism. Refer to Figures 28 and 29 for lubrication requirements and access points.

Key	Description	Recommended Lubricant	Action
A	Spindle bearing oil cup	Mobil DTE Oil Light, or equivalent	Service daily.
B	One-shot lube system	Mobil Vactra Oil #2, or equivalent	Check oil daily – add if required. Pull lube handle every hour during operations.
C	Knee leadscrew grease nipple	Mobilith AW2, or equivalent	Service once each week.
D	Back gear grease nipple	Mobilith AW1, or equivalent	Service weekly when operating in back gear mode.

Figure 27: Lubrication Points

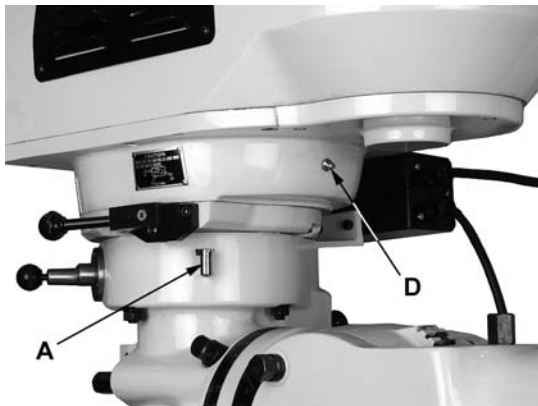

Figure 28

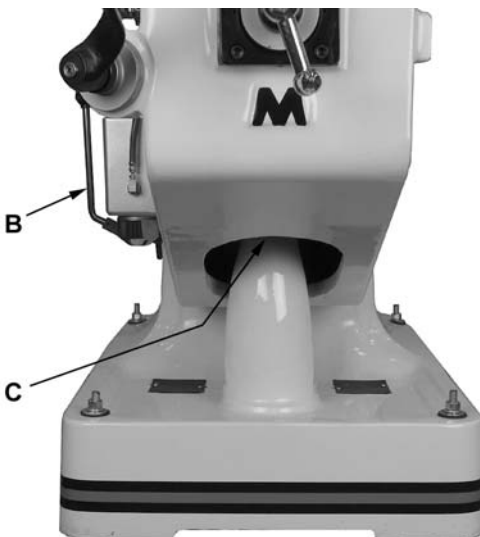

Figure 29

### Periodic Maintenance Requirements

During operation, periodically vacuum and brush chips and debris from machine.

Periodically operate knee and table lead screws through full range of movement to evenly distribute lubricant (particularly when applied using the “one-shot” system).

Periodically apply light machine oil to work table and other exposed metal surfaces to prevent rust or corrosion.

Periodically remove vent panels to check pulleys and belts for unusual wear or grooving. *NOTE: Operators should vary speed occasionally to prevent formation of grooves on the pulley surfaces.*

## Replacement of Drive Motor

Refer to Figure 30 and *Head Assembly* in the *Parts* section.

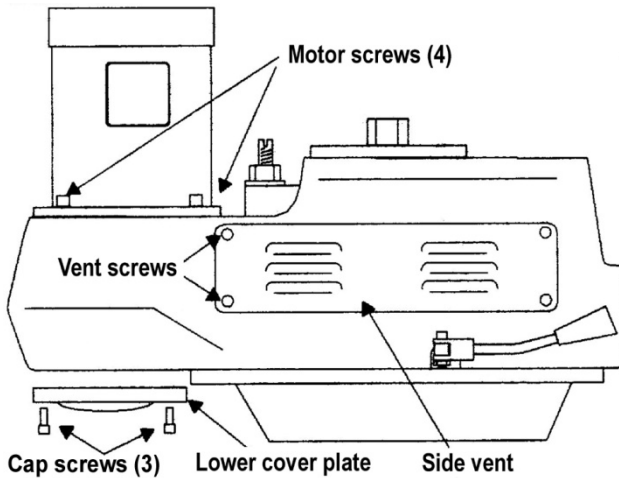

Figure 30

1. Operate spindle at its highest speed.

**⚠ WARNING** Disconnect electrical power to the machine before performing any maintenance.

2. Disconnect electrical power. Remove junction box cover and disconnect wiring. Tag wires to identify leads for reinstallation.
3. Remove vent covers on both sides of head to provide access to the vari-speed belt and pulleys.
4. Remove the lower cover plate under the motor pulley (at the rear of the cover) by removing three cap screws.
5. Remove the four screws that attach the motor.
6. Connect a lifting sling to support and lift the motor during removal. Ease the motor up and forward on the housing.
7. Tilt the motor slightly toward the rear to slacken the vari-speed belt. Remove the vari-speed belt from the motor pulley.
8. Remove the belt; lift the motor clear of the housing.

**⚠ WARNING** Do not attempt to remove the screw from the end of the motor shaft without use of a hydraulic press. Failure to comply may cause serious injury.

The screw retains the underlying spring stop washer, which is under spring tension. Serious injury can result if the spring tension is not gradually released using the hydraulic press. Proceed as follows.

9. Support the drive motor in a hydraulic press. Move the hydraulic ram into contact with the spring stop washer (ref. 9). Remove the screw (ref. 107) from the end of the motor shaft.

10. Slowly release pressure on hydraulic ram until the spring (ref. 8) is fully extended.
11. Remove the lengthening shaft (ref. 106), spring stop washer (ref. 9), spring (ref. 8) and outermost pulley (ref. 5) from the motor shaft.
12. Loosen set screw (ref. 3) on innermost pulley (ref. 2). Remove the pulley (ref. 2) and drive key (ref. 7) from the motor shaft.
13. Install drive key (ref. 7) and pulley (ref. 2) on shaft of replacement motor. Tighten set screw (ref. 3) on pulley.
14. Support the drive motor in a hydraulic press. Place the outermost pulley (ref. 5) on the motor shaft.
15. Install the spring (ref. 8), spring stop washer (ref. 9), and lengthening shaft (ref. 106) on the motor shaft.
16. Move the hydraulic ram into contact with the spring stop washer (ref. 9). Compress the spring (ref. 8) and install the lengthening shaft (ref. 106) on the motor shaft. Install and tighten the attaching screw (ref. 107) in the end of the motor shaft.
17. Using an overhead hoist, lift the replacement motor into position.
18. Tilt the motor slightly toward the rear and install the vari-speed belt on the motor pulleys.
19. Install the four motor attaching screws.
20. Install lower cover plate.
21. Connect electrical wiring to motor junction box.
22. Start the drive motor. Operate the spindle throughout its speed range to check operation.
23. Install vent covers on mill head.

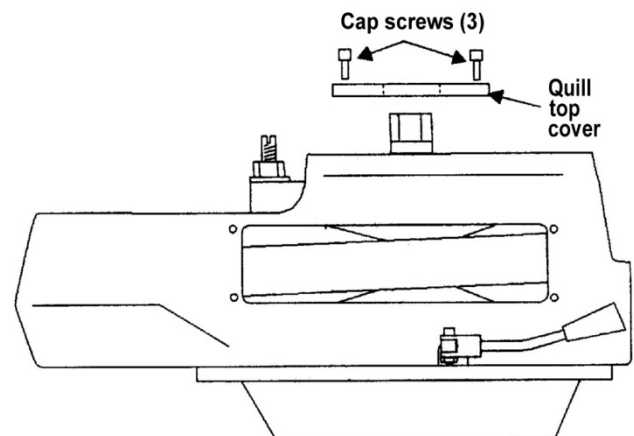

Figure 31

## Replacement of Vari-Speed Belt

Refer to Figures 31 and 32, and *Head Assembly* in the *Parts* section.

**⚠WARNING** Disconnect electrical power to the machine before performing any maintenance.

1. Remove drive motor (refer to the *Replacement of Drive Motor* section).
2. Remove *Quill Top Cover* by removing three cap screws (Figure 31).
3. Remove six cap screws and remove the upper housing (Figure 32).
4. Remove the vari-speed belt (ref. 4).
5. Install the new vari-speed belt (ref. 4) on the driven hub (ref. 44).
6. Install drive motor (refer to the *Replacement of Drive Motor* section).

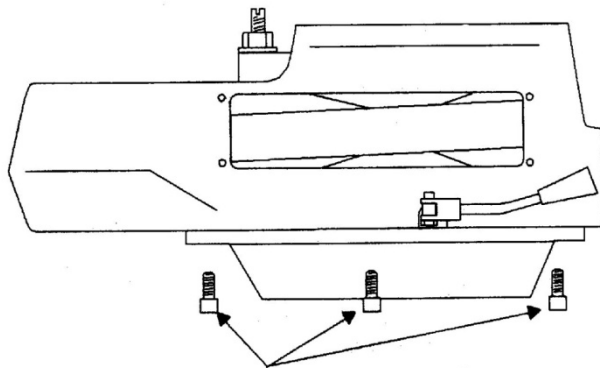

Remove socket head cap screws – three under each side

Figure 32

## Replacement of Brake Shoes, Springs and/or Timing Belt

**⚠WARNING** Disconnect electrical power to the machine before performing any maintenance.

1. Remove drive motor (refer to the *Replacement of Drive Motor* section).
2. Remove vari-speed belt and upper housing (refer to the *Replacement of Vari-Speed Belt* section).
3. Remove screws from lower housing cover (ref. 50).
4. Loosen the setscrew (ref. 3) securing the brake pivot finger stud (ref. 58) in the lower housing cover (ref. 50).
5. Move the pivot finger stud (ref. 58) inward enough to remove the snap ring (ref. 60).

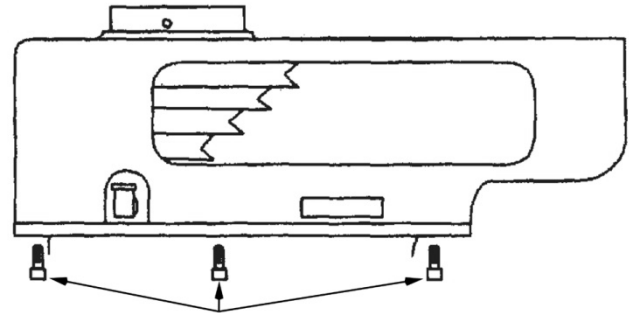

Remove six cap screws – three screws under each side

Figure 33

6. Pull the pivot finger stud (ref. 58) out of the lower housing cover (ref. 50) and the brake pivot fingers (ref. 59).
7. Before removing, note the orientation of the brake pivot fingers (ref. 59) for correct positioning for re-assembly. Remove the pivot fingers.

*If replacing the brake components only, skip Steps 8 and 9 and go to Step 10.*

*To replace the timing belt:*

8. Remove lower housing cover and pulley.
9. Replace belt (ref 63).

*To replace the brake components:*

10. Using a soft-faced mallet, tap upward to separate the lower housing cover (ref. 50) and the brake assembly (ref. 47) from the bearing (ref. 43).
11. Remove the brake shoes (ref. 47) and springs (ref. 49). Install the replacement brake shoes and springs.

*For all:*

12. Position the brake pivot fingers (ref. 59) as noted during removal. Install the pivot finger stud (ref. 58) through the lower housing cover (ref. 50) and into the brake pivot fingers (ref. 59). Install the snap ring (ref. 60) on the pivot finger stud (ref. 58).
13. Tighten the setscrew (ref. 3) to secure the pivot finger stud (ref. 58).
14. Install the brake assembly (ref. 47) on the lower housing cover (ref. 50).
15. Secure the lower housing cover (ref. 50) with four screws.
16. Install timing belt and upper housing.
17. Install vari-speed belt (refer to the *Replacement of Vari-Speed Belt* section).
18. Install drive motor (refer to the *Replacement of Drive Motor* section).

## Replacement of Quill Feed Clock Spring

Refer to the *Spindle Assembly* in the *Parts* section.

**⚠WARNING** Disconnect electrical power to the machine before performing any maintenance.

1. Remove the coarse feed handle.
2. Remove the screw, hub, and key from the coarse feed shaft (ref. 172, 175, and 171).
3. Remove six screws (Ref. 1) and allow the clock spring (ref. 178) to slowly unwind.
4. Remove feed handle hub sleeve (ref. 176).
5. Lift the end of the spring (ref. 178) from the pin (ref. 168) on the pinion shaft (ref. 166).
6. Remove the spring (ref. 178) from the spring cover (ref. 177).
7. Install the replacement spring (ref. 178) in the spring cover (ref 177).
8. Install end of spring (ref. 178) over the pin (ref. 168) on pinion shaft (ref. 166).
9. Install pin (ref. 168) in feed handle hub sleeve (ref. 176) on other end of spring (ref. 178).
10. Turn the spring cover (ref. 177) to wind the spring (ref. 178). Turn the spring cover (ref. 177) until the desired tension is achieved. Hold the spring cover (ref. 177) in position and secure with six screws (ref. 1).
11. Install the key, hub, and screw (ref. 171, 175, and 172) onto the feed shaft (ref. 166).

## Replacement Parts

Replacement parts are listed on the following pages. To order parts or reach our service department, call 1-800-274-6848, Monday through Friday (see our website for business hours, [www.jettools.com](http://www.jettools.com)). Having the Model Number and Serial Number of your machine available when you call will allow us to serve you quickly and accurately.



# Head Assembly

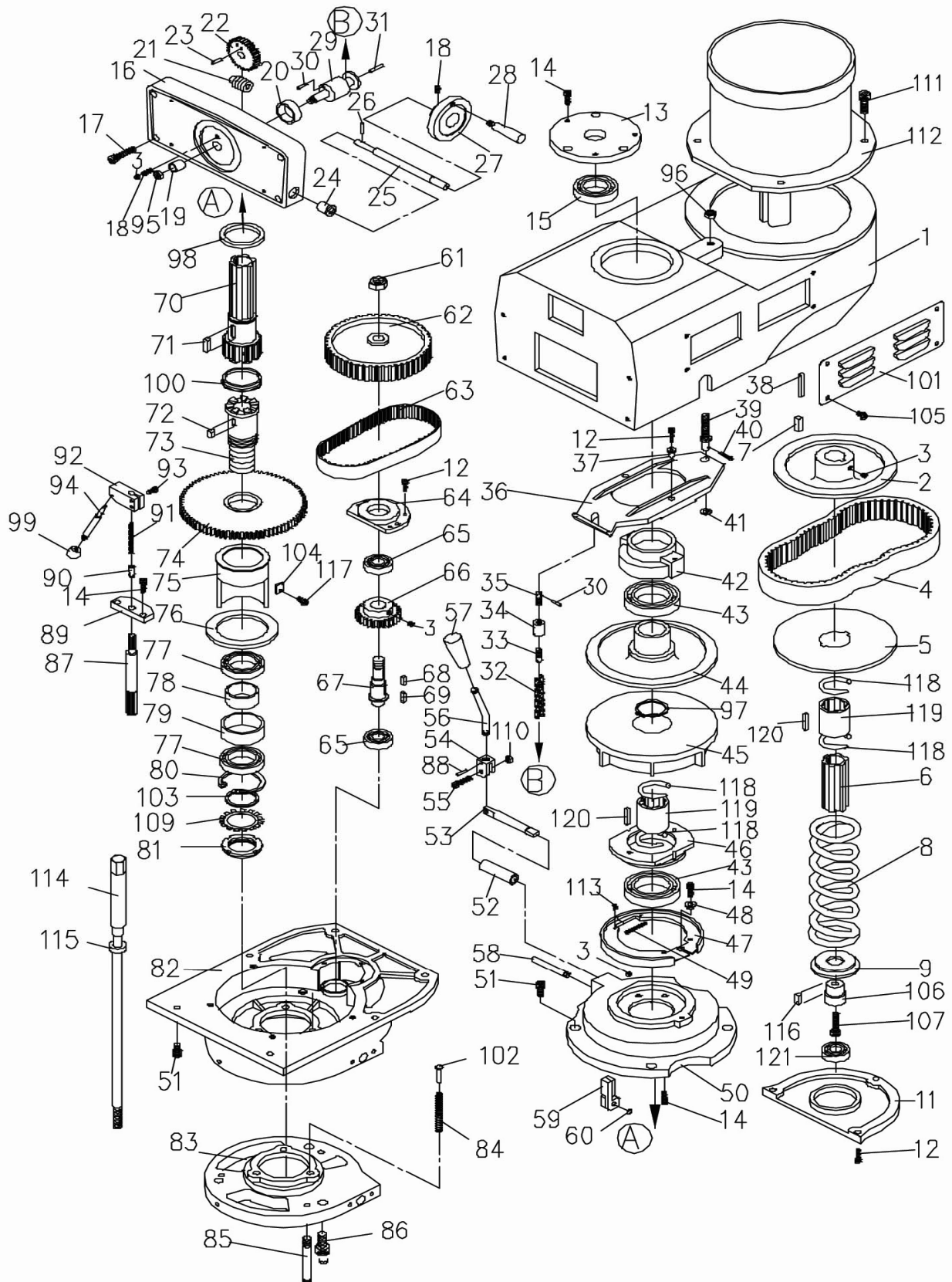

## Parts List for Head Assembly

Index No.	Part No.	Description	Size	Qty
	JTM4VS-HA	Head Assembly w/ Motor		1
1	VS-001G	Upper Housing		1
2	VS-002	Motor Pulley		1
	VS-044A	Motor Pulley Bushing (not shown)		1
3	TS-1503011	Set Screw	M6 x 6	4
4	VS-004	Belt	900VC3830	1
5	VS-005	Motor Pulley Disk		1
6	VS-006	Motor Pulley Shaft		1
7	KEY7725	Key	7 x 7 x 25 mm	1
8	VS-008	Motor Pulley Spring		1
9	VS-009	Spring Stop Washer		1
11	VS-011AG	Motor Pulley Cover		1
12	TS-1502051	Hex Socket Cap Screw	M5 x 20	8
13	VS-013	Cover		1
14	TS-1503041	Hex Socket Cap Screw	M6 x 16	10
15	BB-6007ZZ	Ball Bearing		1
16	VS-016G	Dial Cover		1
16-1	VS-016-1	Dial With Panel Assembly (not shown)		1
17	TS-1503071	Hex Socket Cap Screw	M6 x 30	4
18	TS-1503041	Hex Socket Cap Screw	M6 x 16	2
19	VS-019	Bushing		1
20	VS-020	Bushing		1
21	VS-021	Worm		1
22	VS-022	Worm Gear		1
23	VS-023	Spring Pin	5 x 10 mm	2
24	VS-024	Bushing		2
25	VS-025	Dial Control Shaft		1
26	VS-026	Spring Pin	3 x 12 mm	1
27	VS-027	Dial Wheel		1
28	VS-028	Wheel Handle		1
29	VS-029	Shaft		1
30	VS-030	Spring Pin	4 x 16 mm	2
31	VS-031	Spring Pin	3 x 25 mm	1
32	VS-032	Speed Change Chain		1
33	VS-033	Adjustment Stud		1
34	VS-034	Sleeve Nut		1
35	VS-035	Adjustment Stud		1
36	VS-036	Tilter		1
37	VS-037	Bushing		2
38	KEY6645	Key	6 x 6 x 45 mm	1
39	VS-039	Regulating Screw		1
40	VS-040	Spring Pin	3/32" x 3/4"	1
41	VS-041	Washer		1
42	VS-042	Support		1
43	BB-6010VV	Ball Bearing		2
44	VS-044	Driven Pulley Assembly (s/n:xxx1944 & lower)		1
	VS-044N	Driven Pulley Assembly (s/n:xxx1945 & higher)		1
45	VS-045	Steady Pulley (s/n:xxx1944 & lower)		1
	VS-045N	Steady Pulley (s/n:xxx1945 & higher)		1
46	VS-046	Bearing Cover		1
47	VS-047	Brake Lining		1
48	VS-048	Lock Screw		1
49	VS-049	Brake Spring		2
50	VS-050G	Lower Housing Cover		1
51	TS-1504031	Hex Socket Cap Screw	M8 x 20	4
52	VS-052	Brake Shaft Sleeve		1
53	VS-053	Brake Lock Shaft		1

Index No.	Part No.	Description	Size	Qty
54	VS-054	Brake Lock Block		1
55	TS-1503061	Hex Socket Cap Screw	M6 x 25	1
56	VS-056	Brake Lock Handle		1
57	VS-057	Plastic Ball		2
58	VS-058	Brake Finger Pivot Stud		1
59	VS-059	Brake Stud		2
60	VS-060	Snap Ring	S-8	2
61	TS-0561072	Nut	5/8"-18 UNF	1
62	VS-062	Timing Belt Pulley		1
63	VB-225L100	Timing Belt	225L100	1
64	VS-064	Bearing Retainer		1
65	BB-6203ZZ	Ball Bearing		2
66	VS-066	Bull Gear		1
67	VS-067	Counter Shaft		1
68	VS-068	Key	5 x 5 x 15 mm	1
69	VS-069	Key	5 x 5 x 18 mm	1
70	VS-070	Spindle Pulley Hub		1
71	VS-071	Key	8 x 7 x 24 mm	1
72	VS-072	Key	8 x 7 x 12 mm	1
73	VS-073	Spindle Gear Hub		1
74	VS-074	Spindle Gear Assembly		1
75	VS-075	Rack Cup		1
76	VS-076	Washer		1
77	BB-6908ZZ	Ball Bearing		2
78	VS-078	Bearing Washer		1
79	VS-079	Bearing Washer		1
80	VS-080	Snap Ring		1
81	VS-081	Nut		1
82	VS-082G	Lower Housing		1
83	VS-083G	Fixed Clutch Bracket		1
84	VS-084	Spring		1
85	VS-085	Stud		3
86	TS-1506021	Hex Socket Cap Screw	M12 x 25	3
87	VS-087	Gear Shift Pinion		1
88	VS-088	Pin		1
89	VS-089	Detent Plate		1
90	VS-090	Detent Washer		1
91	VS-091	Spring		1
92	VS-092	Pinion Block		1
93	TS-1503011	Hex Socket Cap Screw	M5 x 14	2
94	VS-094	Pinion Crank		1
95	VS-095	Cap Nut		1
96	TS-0561031	Hex Nut	3/8"	1
97	VS-097	Snap Ring		1
98	VS-098	Wave Washer		1
99	VS-099	Plastic Ball		1
100	VS-100	Snap Ring		1
101	VS-101B	Cover		2
102	VS-102	Spring Shaft		3
103	VS-103	Washer		1
104	VS-104	Copper Washer		2
105	VS-105	Screw	1/4" x 3/8"	8
106	VS-107	Shaft		1
107	TS-1504061	Hex Socket Cap Screw	M8 x 30	1
109	VS-109	Lock Washer		1
110	TS-1540041	Hex Nut	M6	1
111	TS-0209051	Hex Socket Cap Screw	3/8" x 1"	4
112	VS-000G	Motor	3HP 3PH	1
	JTM4VS-112G	Motor	2HP 1PH	1
113	VS-113	Oval Head Screw	1/8" x 1/4"	4

Index No.	Part No.	Description	Size	Qty
114	JTM1-001VS	Draw Bar		1
115	JTM4VS-A002B	Draw Bar Washer		1
116	VS-116	Key		1
117	VS-117	Oval Head Screw	3/16" x 1/2"	1
118	VS-007	Snap Ring		4
119	VS-005A	Plastic Sleeve		2
120	VS-120	Key	6 x 4 x 32 mm	2
121	BB-6206ZZ	Ball Bearing	6206ZZ	1
	VS-000A	Forward-Reverse Switch, 3 Phase (not shown)		1
	JTM2-598CP	Forward-Reverse Switch, 1 Phase (not shown)		1
	JTM1-598D	Switch Box (not shown)		1
	JTM1-598B	Switch Knob (not shown)		1
	LK-041B	Switch Bracket (not shown)		1

# Spindle Assembly

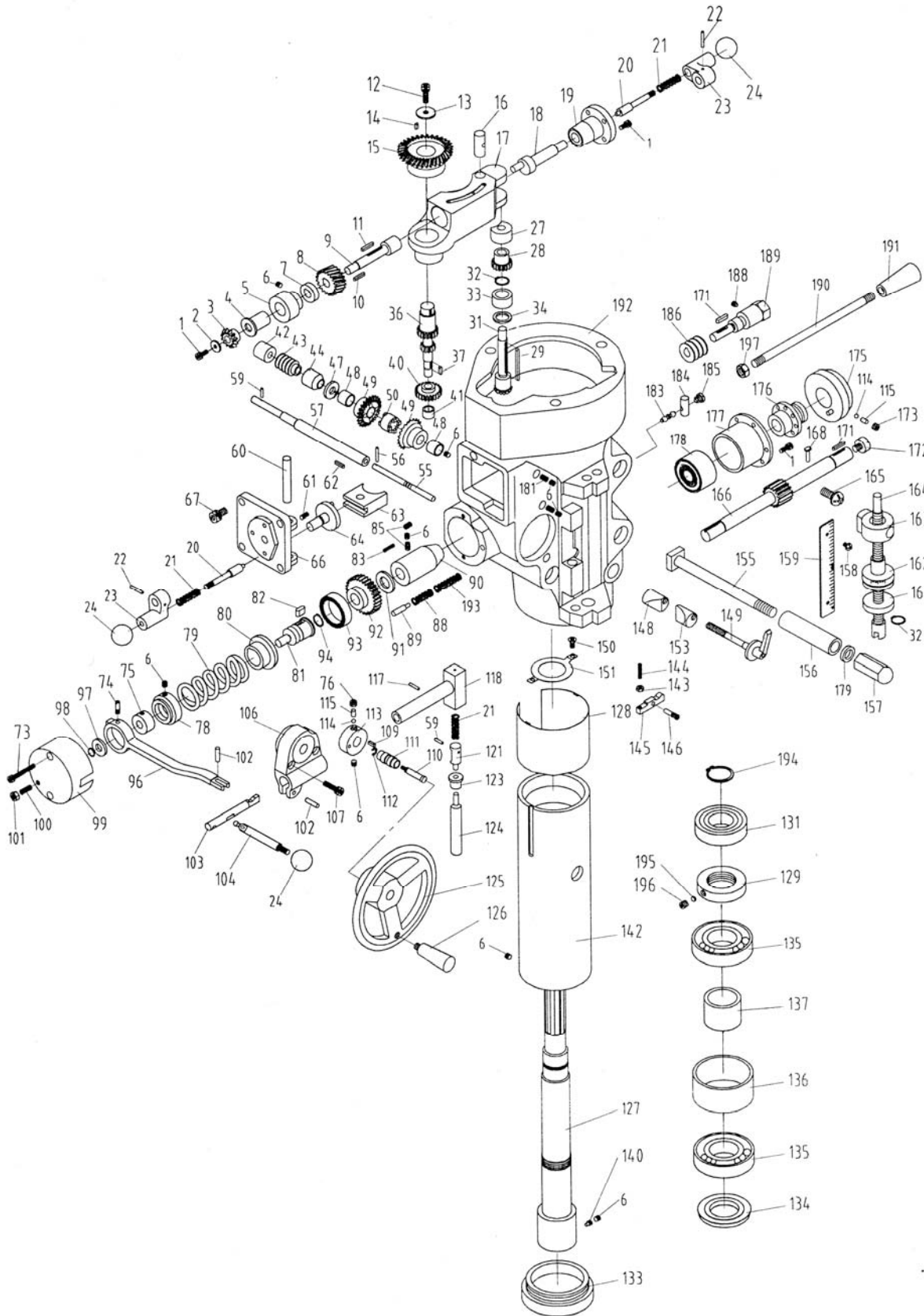

## Parts List for Spindle Assembly

Index No.	Part No.	Description	Size	Qty
1	TS-1533042	Screw	M5 x 10	6
2	HA-002	Bevel Pinion Washer		1
3	HA-003	Feed Gear		1
4	LA-161	Shaft Sleeve		1
5	LA-162	Worm Cradle Bushing		1
6	TS-1523011	Set Screw	M6 x 6	9
7	LA-163	Worm Gear Spacer		1
8	LA-164	Feed Drive Worm Gear		1
9	LA-165	Worm Gear Shaft		1
10	HA-010	Worm Shaft Key	3 x 3 x 8 mm	1
11	HA-011	Key	3 x 3 x 20 mm	1
12	HA-012	Locknut	M6 x 16	1
13	HA-013	Washer		1
14	HA-014	Cluster Gear Key	3 x 3 x 8.5 mm	1
15	LA-154	Feed Reverse Bevel Gear		1
16	LA-167	Feed Engage Pin		1
17	LA-166	Worm Gear Cradle		1
18	LA-033	Worm Gear Throw-Out		1
19	LA-002	Shift Sleeve		1
20	LA-004	Plunger		2
21	LA-005	Spring		3
22	HA-022	Spring Pin	3 x 22 mm	2
23	LA-003	Shift Crank		2
24	LA-006	Plastic Ball		3
27	LA-147	Upper Bushing		1
28	LA-144	Cluster Gear Assembly		1
29	HA-029	Cluster Gear Key	3 x 3 x 45 mm	1
31	LA-143	Cluster Gear Shaft		1
32	HA-032	Snap Ring		2
33	LA-142	Bevel Gear Bushing		1
34	LA-141	Thrust Spacer		1
36	LA-156	Feed Drive Gear		1
37	HA-037	Key	3 x 3 x 10 mm	1
40	LA-157	Feed Drive Gear		1
41	HA-041	Needle Bearing		1
42	LA-168	Bushing		1
43	LA-139	Worm		1
44	LA-138	Feed Worm Shaft Bushing		1
47	LA-137	Bevel Gear Thrust Spacer		1
48	LA-134	Bushing		2
49	LA-135	Feed Reverse Bevel Gear		2
50	LA-136	Feed Reverse Clutch		1
55	LA-132	Reverse Clutch Rod		1
56	HA-056	Spring Pin	3 x 20 mm	1
57	LA-133	Feed Worm Shaft		1
59	HA-059	Spring Pin	3 x 12 mm	2
60	LA-150	Feed Shift Rod		1
61	TS-1522031	Set Screw	M5 x 10	1
62	HA-062	Key	3 x 3 x 15 mm	1
63	LA-149	Feed Gear Shift Fork		1
64	LA-151	Cluster Gear Shift Crank		1
66	LA-148	Cluster Gear Cover		1
67	TS-1504011	Hex Socket Cap Screw	M8 x 10	4
73	TS-1502081	Hex Socket Cap Screw	M5 x 35	2
74	LA-081	Clutch Ring Pin		2
75	LA-080	Clutch Ring		1
76	TS-1524011	Set Screw	M8 x 8	1

Index No.	Part No.	Description	Size	Qty
78	LA-082	Overload Clutch Lockout		1
79	LA-083	Safety Clutch Spring		1
80	LA-084	Overload Clutch	46T	1
	LA-084N	Overload Clutch (serial # 6100913 and up)	50T	1
81	LA-085	Overload Clutch Sleeve		1
82	LA-090	Key		1
83	TS-1532052	Pan Head Machine Screw	M4 x 16	3
85	TS-1523031	Set Screw	M6 x 10	2
88	LA-169	Spring		1
89	LA-089	Spring Plunger		1
90	LA-123	Pinion Shaft Bushing		1
91	LA-122	Spacer		1
92	LA-087	Overload Clutch Worm Gear		1
93	LA-086	Overload Clutch Ring	46T	1
	LA-086N	Overload Clutch Ring (serial # 6100913 and up)	50T	1
94	HA-094	Snap Ring		1
96	LA-079	Trip Lever		1
97	LA-078	Washer		1
98	HA-098	Snap Ring		1
99	LA-076	Clutch Arm Cover		1
100	TS-1523051	Set Screw	M6 x 10	1
101	HA-101	Locknut		1
102	LA-077	Pin		3
103	LA-091	Cam Rod		1
104	LA-100	Trip Handle		1
106	LA-092	Feed Trip Bracket		1
107	TS-1503051	Hex Socket Cap Screw	M6 x 20	2
109	HA-109	Key	3 x 3 x10 mm	1
110	LA-130	Feed Reverse Knob Stud		1
111	LA-131	Reverse Knob		1
112	HA-112	Snap Ring		1
113	LA-129	Handwheel Clutch		1
114	SB-3/16	Steel Ball	3/16"	2
115	HA-115	Spring		2
117	HA-117	Spring Pin		1
118	LA-093	Cam Rod Sleeve Assembly		1
121	LA-095	Trip Plunger		1
123	LA-121	Bushing		1
124	LA-097	Feed Trip Plunger		1
125	LA-126	Handwheel (chrome)		1
	LA-126-BR	Handwheel (brushed finish)		1
126	LA-125	Handle (chrome)		1
	LA-125-BR	Handle (brushed finish)		1
127	LA-050A	Spindle		1
128	LA-060	Quill Skirt		1
129	LA-048	Lock Nut		1
131	BB-6206ZZ	Ball Bearing		1
133	LA-051	Nose Piece		1
134	LA-052	Spindle Shield		1
135	BB-7207C	Ball Bearing		2
136	LA-054	Bearing Spacer (large)		1
137	LA-053	Bearing Spacer (small)		1
140	LA-172	Set Screw		1
142	LA-058	Quill		1
143	TS-154021	Hex Nut	M4	1
144	TS-1521071	Set Screw	M4 x 20	1
145	LA-098	Feed Trip Lever		1
146	LA-099	Trip Lever Pin		1
148	LA-111	Quill Lock Sleeve		1

Index No.	Part No.	Description	Size	Qty
149	LA-109	Lock Handle (chrome)		1
	LA-109-BR	Lock Handle (brushed finish)		1
150	HA-150	Screw	M5 x 10	2
151	LA-057	Felt Washer		1
153	LA-110	Quill Lock Sleeve		1
155	LA-043	T-Bolt Assembly		4
156	LA-046	Spacer		4
157	LA-040	Lock Nut		4
158	HA-158	Screw	M4 x 5	2
159	LA-118	Micrometer Scale		1
161	LA-115	Quill Micro-Stop Nut		1
162	LA-116	Micrometer Nut		1
163	LA-117	Quill Stop Knob		1
164	LA-112	Quill Micro-Screw		1
165	LA-165A	Screw	3/8"-24UNF x 3/4"	1
166	LA-101	Quill Pinion Shaft		1
168	LA-101A	Pin		1
171	HA-171	Key		2
172	LA-107	Pinion Shaft Hub		1
173	TS-0270021	Set Screw	5/16" x 1/4"	1
175	LA-106	Hub		1
176	LA-104	Hub Sleeve		1
177	LA-103	Spring Cover		1
178	LA-102	Clock Spring		1
	LA-102/3	Clock Spring Assembly		1
179	TS-0680061	Washer	1/2"	1
181	TS-1523011	Set Screw	M6 x 6	2
183	LA-113	Lever		1
184	LA-114	Plunger		1
185	LA-124	Screw		1
186	LA-018	Worm Gear		1
188	LA-173	Set Screw		1
189	LA-019	Worm Shaft		1
190	LA-105	Handle		1
191	LB-017	Plastic Ball		1
192	LA-016G	Quill Housing		1
193	HA-193	Spring	10 x 20 mm	1
194	RINS30	Snap Ring		1
195	HB1291	Lock Washer		1
196	TS-1524011	Set Screw	M8 x 8	1
197	TS-0561031	Hex Nut	3/8"	1
	LA-166A	Worm Gear Cradle Assembly (index # 1-17,36,37,40)		1



# Base Assembly

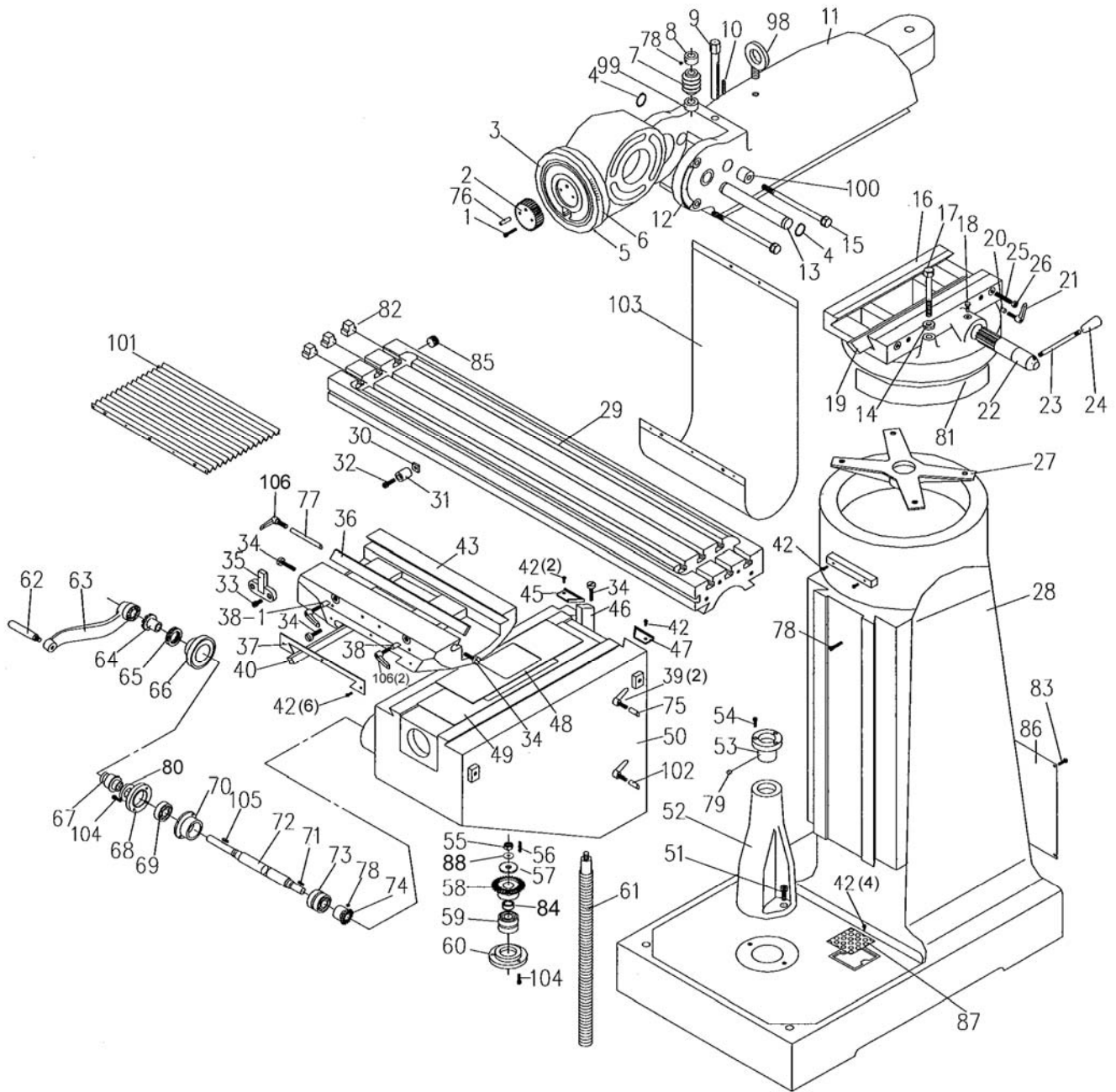

## Parts List for Base Assembly

Index No.	Part No.	Description	Size	Qty
1	LB-001	Set Screw	M6 x30	2
2	LB-023	Gear		1
3	LB-020G	Ram Adapter		1
4	LB-004	Snap Ring	S-28	2
5	LB-005	Rivet		5
6	LB-027	Adapter Scale		1
7	LB-035	Worm		1
8	LB-036	Worm Thrust Washer		1
9	LB-034	Shaft		1
10	LB-100	Key	5 x 5 x 40 mm	1
11	MB-026G	Ram		1
12	LB-032	Angle Plate		1
13	LB-028	Adapter Pivot Stud		1
14	LB-031	Washer		4
15	LB-030	Adapter Locking Bolt		3
16	MB-009G	Turret		1
	MB-00B	Turret Scale (not shown)		1
17	LB-030	Lock Bolt		4
18	LB-041	Ram Pinion Screw		1
19	LB-011	Ram/Turret Gib		1
20	LS-005E	Lock Plunger		2
21	LB-014	Ram Lock Bolt Handle		2
22	LB-015	Ram Pinion		1
23	LB-016	Ram Pinion Handle Rod		1
24	LB-017	Black Plastic Ball		1
25	TS-0211131	Set Screw	3/8" x 2"	2
26	TS-0561031	Hex Nut	3/8"	2
27	MB-008	Spider		1
28	MB-000AG	Column		1
29	MT000B	Table		1
30	LT-027	Stop Nut		2
31	LT-028	Table Stop		2
32	TS-1504071	Hex Socket Cap Screw	M8 x 35	2
33	TS-1504031	Hex Socket Cap Screw	M8 x 16	2
34	LK-002	Gib Adjusting Screw		6
35	LS-003	Table Stop Bracket		1
36	LS-008	Saddle/Table Gib		1
37	LS-013	Felt Wiper		2
38	LS-005R	Table Lock Plunger – R	16mm	1
38-1	LS-005L	Table Lock Plunger – L	13mm	1
39	LS-011	Knee Lock Handle		2
40	LS-001	Saddle/Knee Gib		1
42	LS-042	Screw	3/16"	20
43	MS-000G	Saddle		1
45	LS-016A	Felt (left)		1
46	LK-001	Knee/Column Gib		1
47	LS-016B	Knee/Wiper Felt (right)		1
48	LK-007	Upper Chip Guard		1
49	LK-006	Lower Chip Guard		1
50	MK-000G	Knee		1
51	TS-1505031	Hex Socket Cap Screw	M10 x 25	2
52	MK-012G	Elevating Screw Housing		1
53	MK-014	Elevating Screw Nut		1
54	TS-1503041	Hex Socket Cap Screw	M6 x 16	8
55	TS-0561052	Hex Nut	1/2-20UNF	1
56	LK-058	Key	4 x 4 x 30 mm	1

Index No.	Part No.	Description	Size	Qty
57	LK-022	Washer		1
58	MK-021	Bevel Gear		1
59	BB-6306ZZ	Ball Bearing		2
60	MK-019	Bearing Retainer Ring		1
61	MK-016	Elevating Screw		1
62	LK-037	Handle (chrome)		1
	LK-037-BR	Handle (brushed finish)		1
63	LK-036	Elevating Crank		1
64	LK-035	Clutch Insert		1
65	LK-034	Dial Lock Nut		1
66	LK-033	Dial		1
67	LK-032	Dial Holder		1
68	LK-030	Bearing Retainer Ring		1
69	BB-6204ZZ	Ball Bearing		1
70	LK-029	Bearing Cap		1
71	LK-075	Key	4 x 4 x 18 mm	2
72	MK-028	Elevating Shaft		1
73	BB-6204ZZ	Ball Bearing		2
74	MK-024	Bevel Pinion		1
75	LK-003B	Plunger	32mm	1
76	LK-081	Spring Pin	8 x 30 mm	1
77	LS-010A	Saddle Lock Plunger	116mm	1
78	TS-1515001	Hex Socket Cap Screw	M8 x 12	1
79	JTM4VS-B79	Grease Nipple	1/8"PT	1
80	JTM4VS-B80	Spacer		1
81	JTM4VS-B81	Turret Scale		1
82	JTM4VS-B82	Rubber T-Nut		6
83	MB-090	Screw	1/4" x 3/8"	4
84	MK-038	Bushing		1
85	VM-I40	Oil Plug	3/8" PT	2
86	MB-004	Cover		1
87	MB-041	Strainer Screen		2
88	JTM4VS-B88	Lock Washer		1
98	RIBW34	Hoisting Ring		1
99	LB-036	Worm Thrust Washer		1
100	LB-033	Thrust Washer		1
101	LS-018	Pleated Way Cover		1
102	LK-003C	Lock Plunger	35mm	1
103	LS-017C	Flat Way Cover		1
104	TS-1503051	Hex Socket Cap Screw	M6 x 20	6
105	KEY3320	Key	3 x 3 x 20 mm	1
107	LS-006B	Saddle Ratcheting Lever (chrome)		3
	LS-006B-BR	Saddle Ratcheting Lever (brushed finish)		3
	JTM4VS-TB	Tool Box Kit Complete (not shown)		1
	LC051	Plastic Electric Cover (not shown)		1
	LC051A	Plastic Electric Cover Assembly (not shown)		1

*(Includes switch wire, cover, terminal bracket, power wire, retainer)*

# Lead Screw Assembly

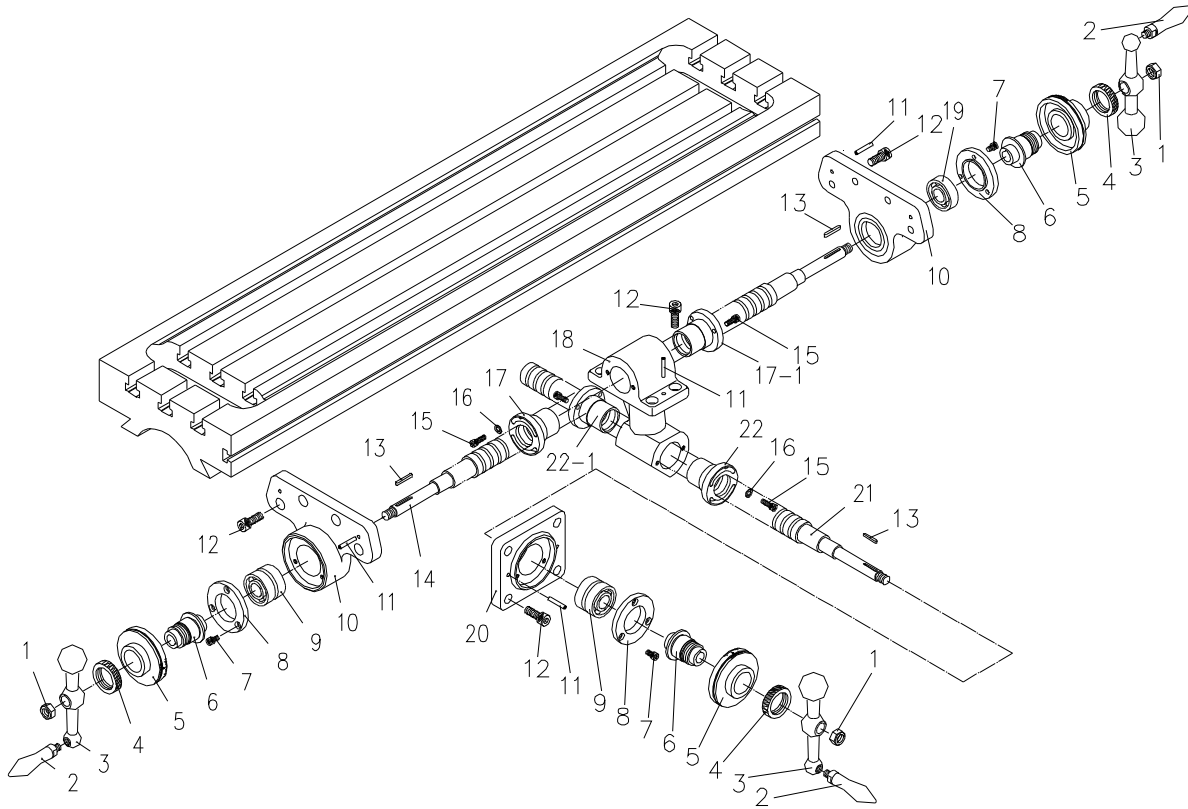

Index No.	Part No.	Description	Size	Qty
1	TS-0571052	Jam Nut	1/2-20UNF	3
2	LT-010C	Handle		3
	LT-010C-CHR	Chrome Surface Handle		3
3	LT-010B	Ball Crank		3
	LT-010BSP-CHR	Clutch Ball Crank (for powerfeed only)	chrome surface	3
	LT-010BSP	Clutch Ball Crank (for powerfeed only)		3
4	LT-009	Dial Lock Nut		3
5	LT-008	Dial		3
6	LT-007	Dial Holder		3
7	TS-150301	Hex Socket Cap Screw	M6 x 12	9
8	LT-005	Bearing Retainer Ring		3
9	BB-6204ZZ	Ball Bearing		3
10	LT-002	Bearing Bracket		2
11	LS-009	Spring Pin	5 x 30 mm	8
12	TS-1505031	Hex Socket Cap Screw	M10 x 25	16
13	LS-014A	Key	3 x 3 x 25 mm	3
14	MT-015D	Leadscrew		1
15	TS-1503041	Hex Socket Cap Screw	M6 x 16	10
16	TS-1550051	Washer	M7	4
17	MT-019B	Feed Screw Nut (set of 2; includes index # 17-1)		1
18	MT-017	Feed Nut Bracket		1
19	BB-6204ZZ	Ball Bearing		1
20	MT-025	Cross Feed Bearing Bracket		1
21	MT-024	Cross Feed Screw		1
22	MT-022	Cross Feed Nut (set of 2; includes index # 17-22)		1

# One-Shot Lubrication System

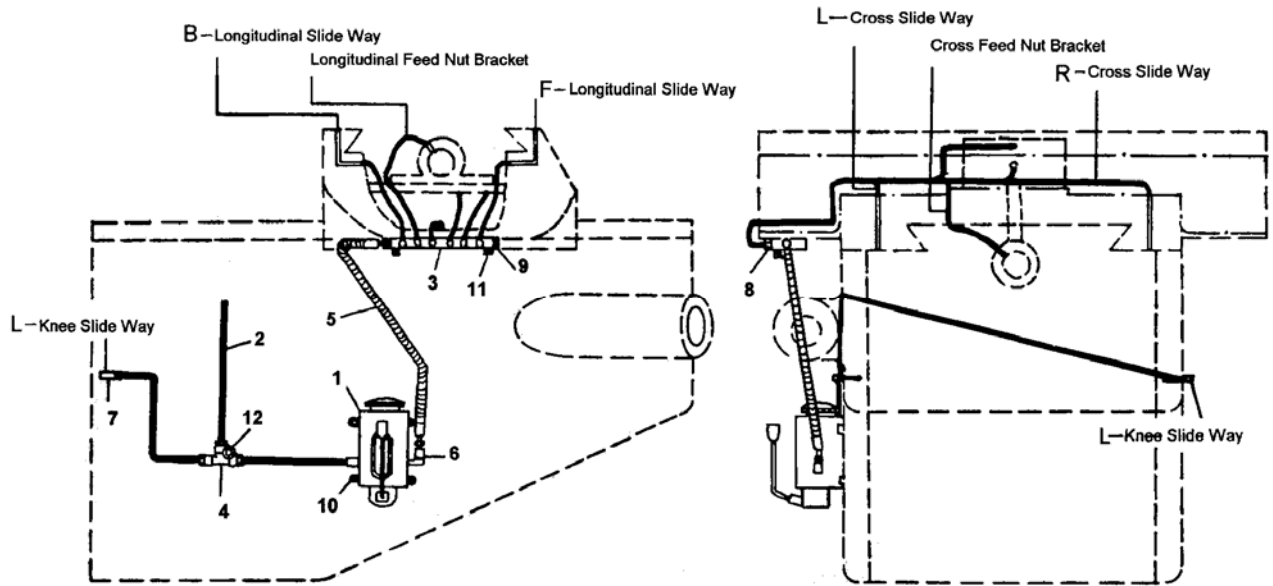

Index No.	Part No.	Description	Size	Qty
.....	LT-8-A.....	Hand Oiler Assembly (includes index #1,1A,4,5, 9) .....		1
1.....	LT-8.....	Hand Oiler .....		1
1A.....	LT-8-SG.....	Hand Oiler Sight Glass (w/gasket).....		1
2.....	ALMP-04.....	Aluminum Pipe .....	3.5M .....	1
.....	ALMP-04-VS.....	Oil Line Set w/ Fittings .....		1
3.....	DB-4.....	Oil Regulating Distributor .....		1
4.....	PKD-4.....	T-Joint .....		1
5.....	FHC-404.....	Flexible Steel Tube .....		1
6.....	PH-1-1/PB-4.....	Check Joint.....		2
7.....	PH-4.....	Elbow Joint .....		2
8.....	PA-4/PB-4.....	Straight Joint.....		14
9.....	PG-004.....	Union.....		1
10.....	JTM4VS-BUTW1458.....	Screw .....		4
11.....	TS-1503061.....	Hex Socket Cap Screw .....	M6 x 25 .....	2
12.....	TS-1502061.....	Hex Socket Cap Screw .....	M5 x 25 .....	1

**Electrical Connections – Single Phase only**

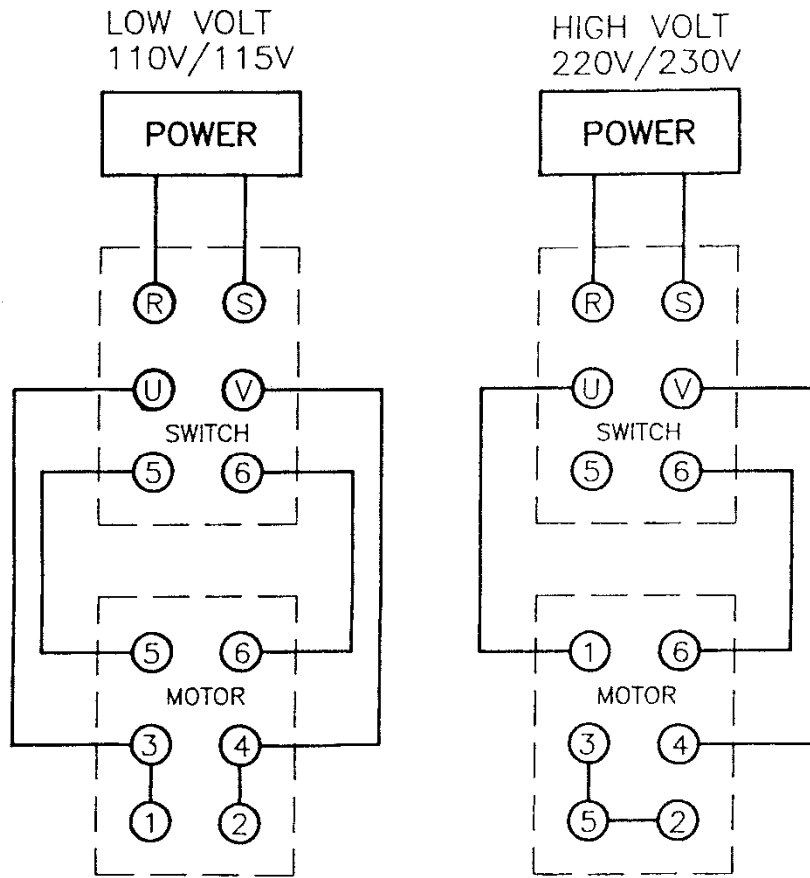

Electrical Connections – 3 Phase only

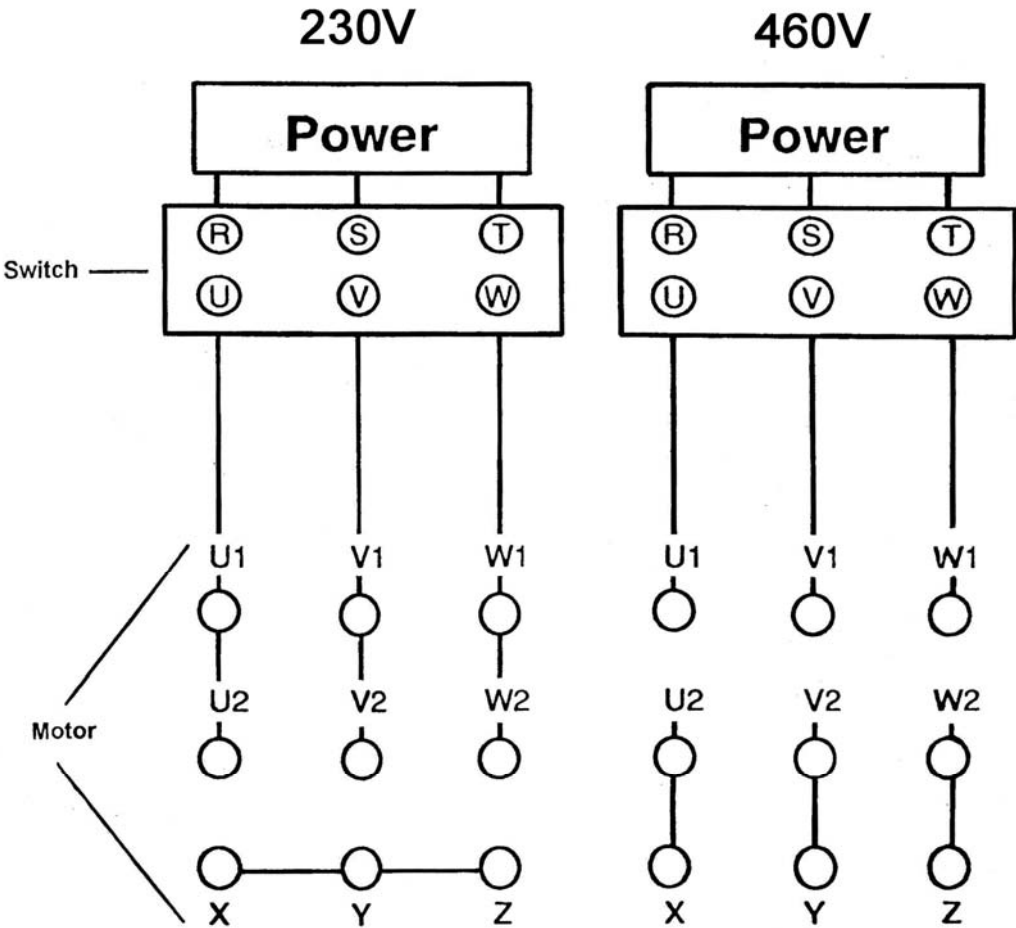



427 New Sanford Road  
LaVergne, Tennessee 37086  
Phone: 800-274-6848  
[www.jettools.com](http://www.jettools.com)