

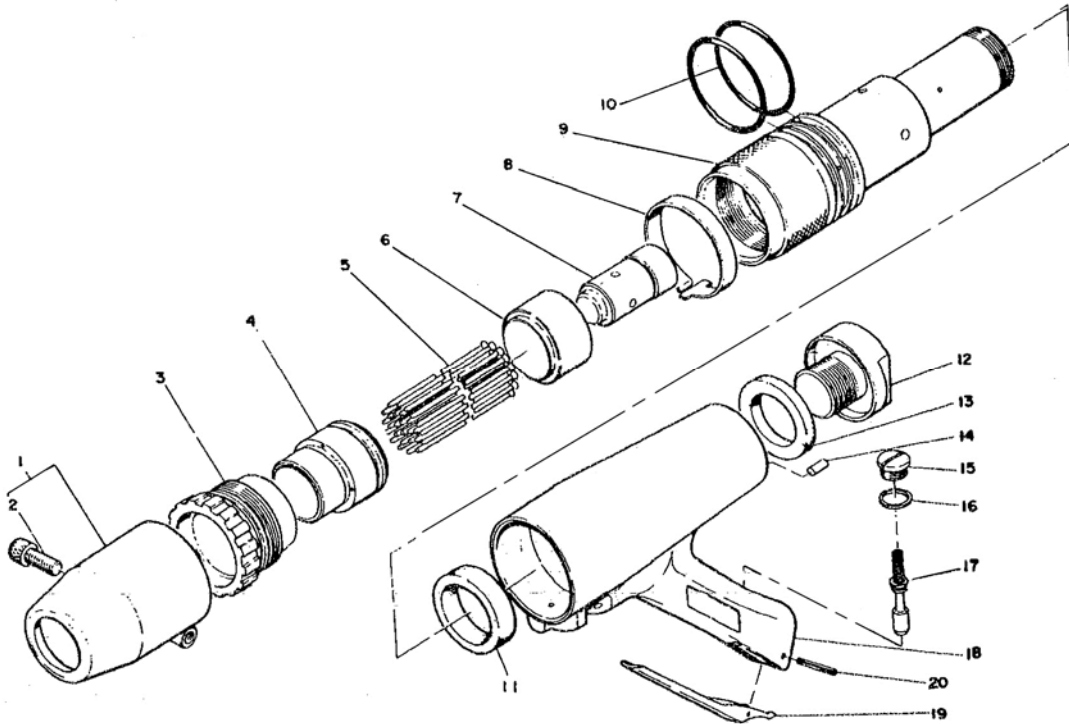

Parts List for JSG-3328NS Pistol Grip Needle Scaler



Index	Part No.	Description	Qty.
1	93A365	Needle Guide Assembly	1
2	00A045	Hex Soc. Hd. Bolt 8x25	1
3	01B464	Stop Ring	1
4	01A461	Needle Supporter 3mm	1
	01A462	Needle Supporter 4mm	1
5	00A341	Needle 3x180mm	28
	00A402	Needle 4x180mm	14
6	00A399	Throttle Anvil	1
7	00A395	Piston	1
8	01A466	Safety Band	1
9	01B463	Cylinder	1
10	11A993	O-Ring W-4	2

Index	Part No.	Description	Qty.
11	01A474	Front Washer	1
12	90A452	Rear Bolt Assembly	1
13	01A475	Rear Washer	1
14	01A478	Cylinder Lock Pin	1
15	00A389	Valve Cap	1
16	00A388	Valve Packing	1
17	90A037	Throttle Valve Assembly	1
18	90C410	Housing Sub Assembly	1
19	01A557	Throttle Lever	1
20	01A802	Spring Pin 3x28	1

RBK-3328NS Rebuild Kit (contains #4,7,10,14,16)

Replacement Parts

To order parts or reach our service department, call 1-800-274-6848 Monday through Friday (see our website for business hours, www.jettools.com). Having the Model Number and Serial Number of your product available when you call will allow us to serve you quickly and accurately.

JET

427 New Sanford Road
 LaVergne, Tennessee 37086
 Ph.: 800-274-6848
www.jettools.com

Part No. M-JSG-3328NS

Revision B 08/2014

Copyright © 2014 JET, a Division of JPW Industries, Inc.

Changing Needles

1. Loosen the hex socket head bolt (#2) of the needle guide (#1) with the Allen wrench, and remove the needle guide.
2. Remove the Safety Band (#8) from the grip groove. See Figure 1.
3. Unscrew the Stop Ring (#3) and remove. Remove the Needle Supporter (#4) by pulling out the needles. See Figure 2.
4. Extract the needles. The needles must be changed whenever damage has occurred during operation.
5. Place new needles into needle support and assemble in reverse manner of disassembly.

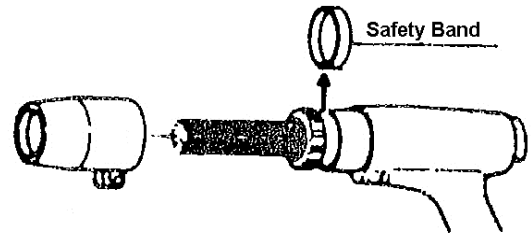

Figure 1

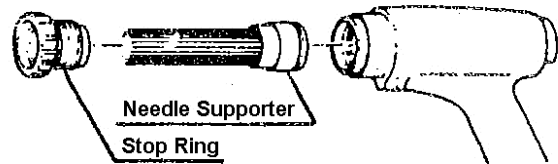

Figure 2

Specifications

Stock Number	JSG-3328NS
Blows per minute.....	4500
Stroke Length (in.).....	.5/8
Number of needles.....	28 or 14
Size of needles (mm)	3 or 4
Air Pressure (PSI)	90
Air Consumption (CFM)8
Air Inlet (NPT/in.).....	.1/4
Air Hose (ID/in.).....	.3/8
Vibration Value (m/s ²)	14.6
Overall Length (in.).....	14
Shipping Weight (lbs.).....	.8

The above specifications were current at time of publication, but because of our policy of continuous improvement, JET reserves the right to change specifications at any time and without prior notice, without incurring obligations.