

RYOBI JIG SAW – MODEL NUMBERS JS651L/JS651L1

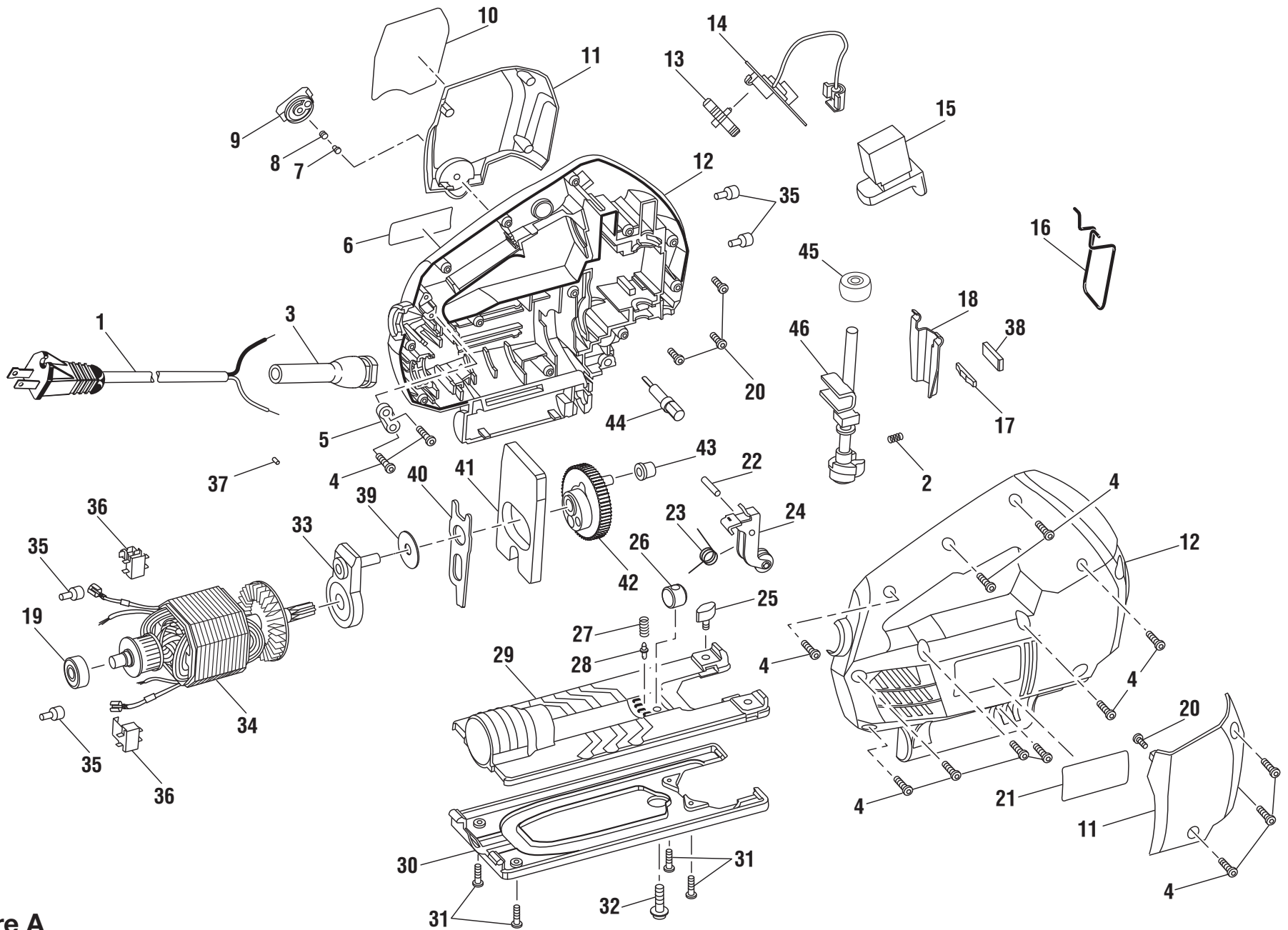

Figure A

## RYOBI JIG SAW – MODEL NUMBERS JS651L/JS651L1

The model number will be found on a label attached to the motor housing. Always mention the model number in all correspondence regarding your **JIG SAW** or when ordering repair parts.

### PARTS LIST

KEY NO.	PART NUMBER	DESCRIPTION	QTY	KEY NO.	PART NUMBER	DESCRIPTION	QTY
1	730372033	Power Cord.....	1	29	641933001	Saw Base.....	1
2	693240001	Compression Spring.....	1	30	521927001	Base Plate.....	1
3	551060001	Bend Relief.....	1	31	660211006	Screw (M3 x 6 mm).....	4
4	660208052	Screw (M4 x 16 mm, Pan Hd.).....	14	32	661276001	Screw (M5 x 20 mm).....	1
5	5950101	Cord Clamp.....	1	33	305493001	Bearing Plate.....	1
6	940114178	Logo Label.....	1	34	305467001	Motor Assembly (Incl. Key No. 19) (JS651L).....	1
7	550424001	Detent Button.....	1		202338001	Motor Assembly (Incl. Key No. 19) (JS651L1).....	1
8	680909001	Compression Spring.....	1	35	790009001	Wire Connector.....	4
9	523838001	Orbital Knob.....	1	36	290069044	Brush Assembly (JS651L).....	2
10	940533094	Gauge Label.....	1		291118002	Brush Assembly (JS651L1).....	2
11	202046001	Cover Assembly.....	1	37	550339001	Rubber Plug.....	1
12	202047001	Housing Assembly (JS651L).....	1	38	524110001	Retaining Block.....	1
	202047002	Housing Assembly (JS651L1).....	1	39	630844001	Washer.....	1
13	523836001	Speed Dial.....	1	40	301627001	Drive Plate.....	1
14	280202003	Circuit Board Assembly.....	1	41	671008001	Counterbalance (JS651L).....	1
15	760476001	Switch Assembly.....	1		611716001	Counterbalance (JS651L1).....	1
16	634174001	Blade Guard.....	1	42	300924003	Output Gear Assembly (JS651L).....	1
17	631252001	Spring Plate.....	1		305491001	Output Gear Assembly (JS651L1).....	1
18	630845001	Guide Plate.....	1	43	305104002	Bushing w/Needle Bearing.....	1
19	680141013	Ball Bearing (608ZZ).....	1	44	673054001	Orbital Pin.....	1
20	6620315	Screw (M3 x 10 mm, Pan Hd.).....	4	45	611841001	Bushing.....	1
21	940488350	Data Label (JS651L).....	1	46	304944001	Saw Bar Assembly.....	1
	941121062	Data Label (JS651L1).....	1		<b>NOT SHOWN</b>		
22	673058001	Pin.....	1		631097001	Edge Guide.....	1
23	693114003	Torsion Spring.....	1		681215001	Hex Key (M4).....	1
24	305061001	Blade Guide Assembly.....	1		690227053	Metal Cutting Blade.....	1
25	305287001	Edge Guide Knob.....	1		902651002	Tool Bag.....	1
26	692668001	Base Angle Nut.....	1		690227051	Wood Cutting Blade.....	2
27	692670001	Compression Spring.....	1		988000799	Operator's Manual.....	1
28	692667001	Spherical Pin.....	1		6-7-13		
					(REV:04)		

**WARNING: Improper repair of a double insulated tool can result in damage to the double insulation system possibly causing electrical shock or electrocution. Any repairs requiring disassembly of your tool requires safety testing and should only be performed by a Ryobi Authorized Service Center. For the service center nearest you call 1-800-525-2579.**