

RYOBI 3/4 in. ORBITAL JIG SAW WITH LASER - MODEL NUMBER JS451L

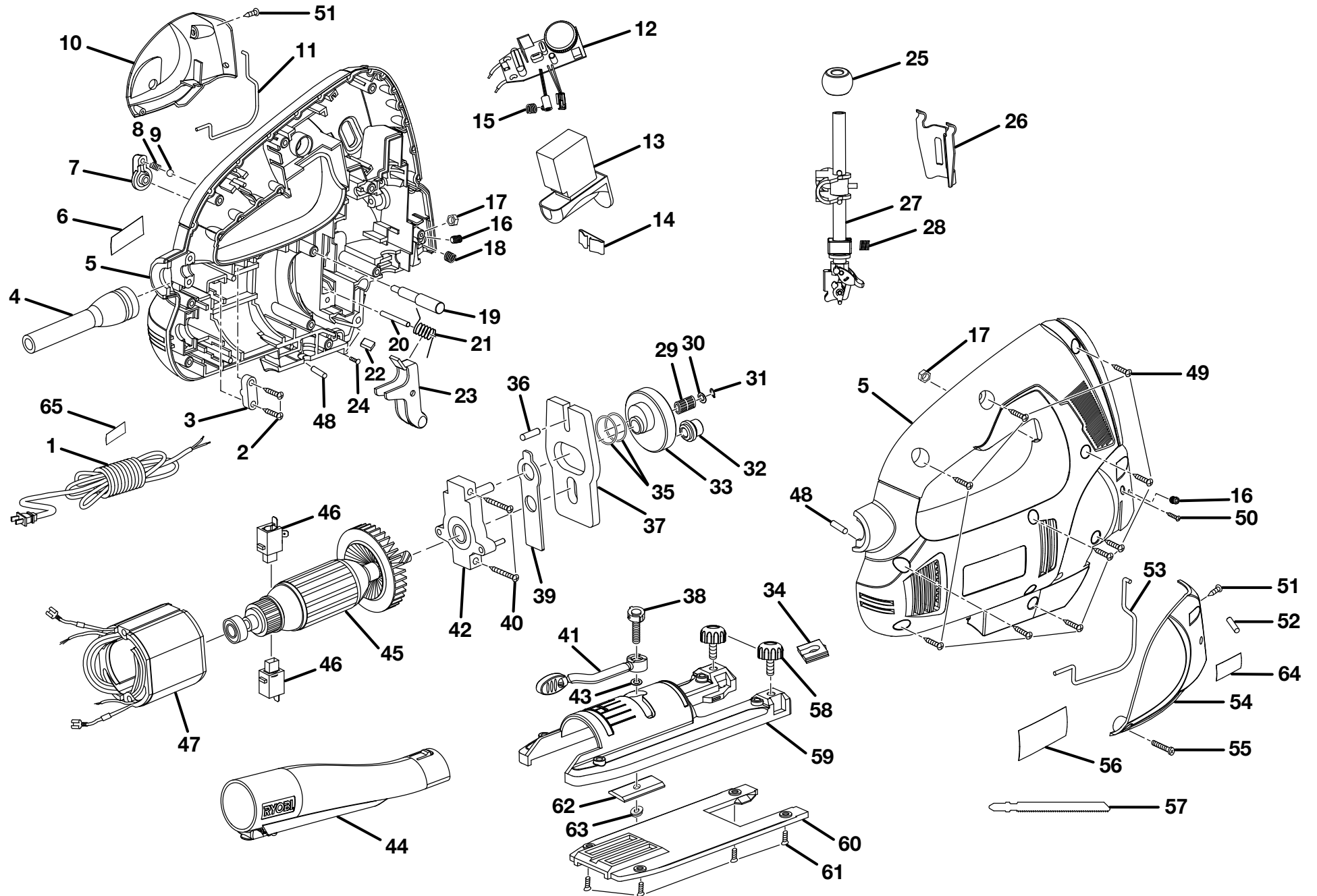

## RYOBI 3/4 in. ORBITAL JIG SAW WITH LASER – MODEL NUMBER JS451L

The model number will be found on a plate attached to the motor housing. Always mention the model number in all correspondence regarding your **JIG SAW** or when ordering repair parts.

### PARTS LIST

Key No.	Part Number	Description	Qty.	Key No.	Part Number	Description	Qty.
1	039076001001	POWER CORD.....	1	19	039064001021	ORBITAL ADJUSTABLE ROD .....	1
2	039064001004	* SCREW (M4.2 x 16 mm) .....	2	20	039064001022	PIN .....	1
3	039076001002	CORD CLAMP .....	1	21	039064001023	TORSION SPRING.....	1
4	039076001003	BEND RELIEF .....	1	22	039076001017	RETAINING PLATE.....	2
5	039076001004	HOUSING ASSEMBLY .....	1	23	039064001024	BLADE GUIDE ASSEMBLY .....	1
6	039076001043	LOGO LABEL.....	1	24	039076001019	* SCREW (M3 x 10 mm) .....	1
7	039076001007	ORBITAL ADJUSTMENT KNOB.....	1	25	039064001025	SLEEVE BEARING .....	1
8	039064001012	SPRING.....	1	26	039064001029	GUIDE PLATE .....	1
9	039064001013	STEEL BALL.....	1	27	039064001030	SAW BAR ASSEMBLY .....	1
10	039076001008	LEFT COVER.....	1	28	039076001071	COMPRESSION SPRING .....	1
11	039076001009	LEFT WIRE.....	1	29	039064001040	NEEDLE BEARING.....	1
12	039076001010	CIRCUIT BOARD .....	1	30	039064001041	WASHER.....	1
13	039076001011	SWITCH .....	1	31	039064001042	RETAINING RING.....	1
14	039064001019	SPRING PLATE .....	1	32	039076001069	DRIVE SLEEVE w/BEARING ASSEMBLY .....	1
15	039076001070	TAPERED SPRING.....	1	33	039064001047	GEAR ASSEMBLY.....	1
16	039076001014	* SET SCREW (M3 x 6 mm).....	2	34	039076001038	ANTI-SPLINTERING INSERT .....	1
17	039076001015	HEX NUT (M3).....	2	35	039076001022	WASHER.....	2
18	039076001016	COMPRESSION SPRING .....	1	36	039064001049	PIN .....	1

\* Standard Hardware Item – May Be Purchased Locally

## RYOBI 3/4 in. ORBITAL JIG SAW WITH LASER – MODEL NUMBER JS451L

The model number will be found on a plate attached to the motor housing. Always mention the model number in all correspondence regarding your **JIG SAW** or when ordering repair parts.

### PARTS LIST

Key No.	Part Number	Description	Qty.	Key No.	Part Number	Description	Qty.
37	039064001050	COUNTERBALANCE .....	1	54	039076001033	RIGHT COVER .....	1
38	039064001051	POSITIVE STOP SCREW .....	1	55	039076001073	* SCREW (M2.9 x 13 mm) .....	1
39	039064001053	DRIVE PLATE .....	1	56	039076001044	DATA LABEL.....	1
40	039064001054	* SCREW (M4.2 x 30 mm) .....	2	57	039076001039	MULTI PURPOSE BLADE (100 mm) .....	1
41	039076001023	BASE ADJUSTMENT LEVER.....	1	58	039076001034	KNOB SCREW .....	2
42	039064001056	BEARING PLATE ASSEMBLY .....	1	59	039076001035	SAW BASE.....	1
43	039076001072	WASHER.....	1	60	039076001036	BASE PLATE .....	1
44	039076001040	VACUUM ATTACHMENT.....	1	61	039064001074	* SCREW (M4 x 10 mm) .....	4
45	039076001068	ARMATURE ASSEMBLY .....	1	62	039064001075	CLAMP PAD.....	1
46	039076001066	BRUSH ASSEMBLY .....	2	63	039064001076	LOCK NUT (M5) .....	1
47	039076001028	FIELD ASSEMBLY.....	1	64	039076001045	LASER LABEL.....	1
48	039076001031	RUBBER PLUG.....	2	65	039076001046	CORD TAG LABEL .....	1
49	039064001065	* SCREW (M4.2 x 16 mm) .....	10	66	039076001059	TOOL BAG (NOT SHOWN) .....	1
50	039064001066	* SCREW (M2.9 x 16 mm) .....	1		987000391	OPERATOR'S MANUAL (039076001048)	
51	039064001067	* SCREW (M4.2 x 16 mm) .....	2		08-22-08	(REV:00)	
52	039076001065	RUBBER PLUG.....	1				
53	039076001032	RIGHT WIRE .....	1				

\* Standard Hardware Item – May Be Purchased Locally