

# MAIN FRAME ASSEMBLY

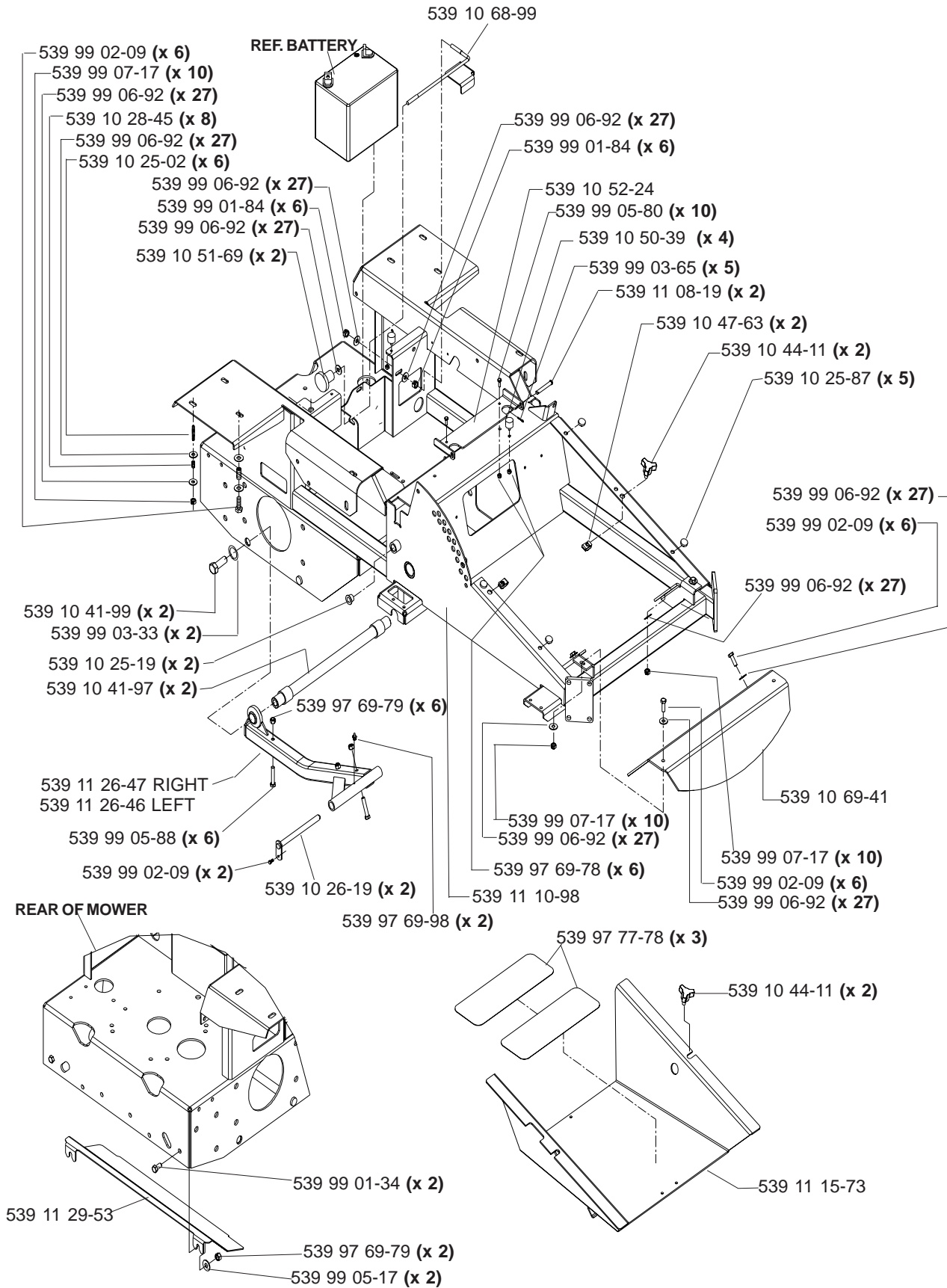

# MAIN FRAME ASSEMBLY

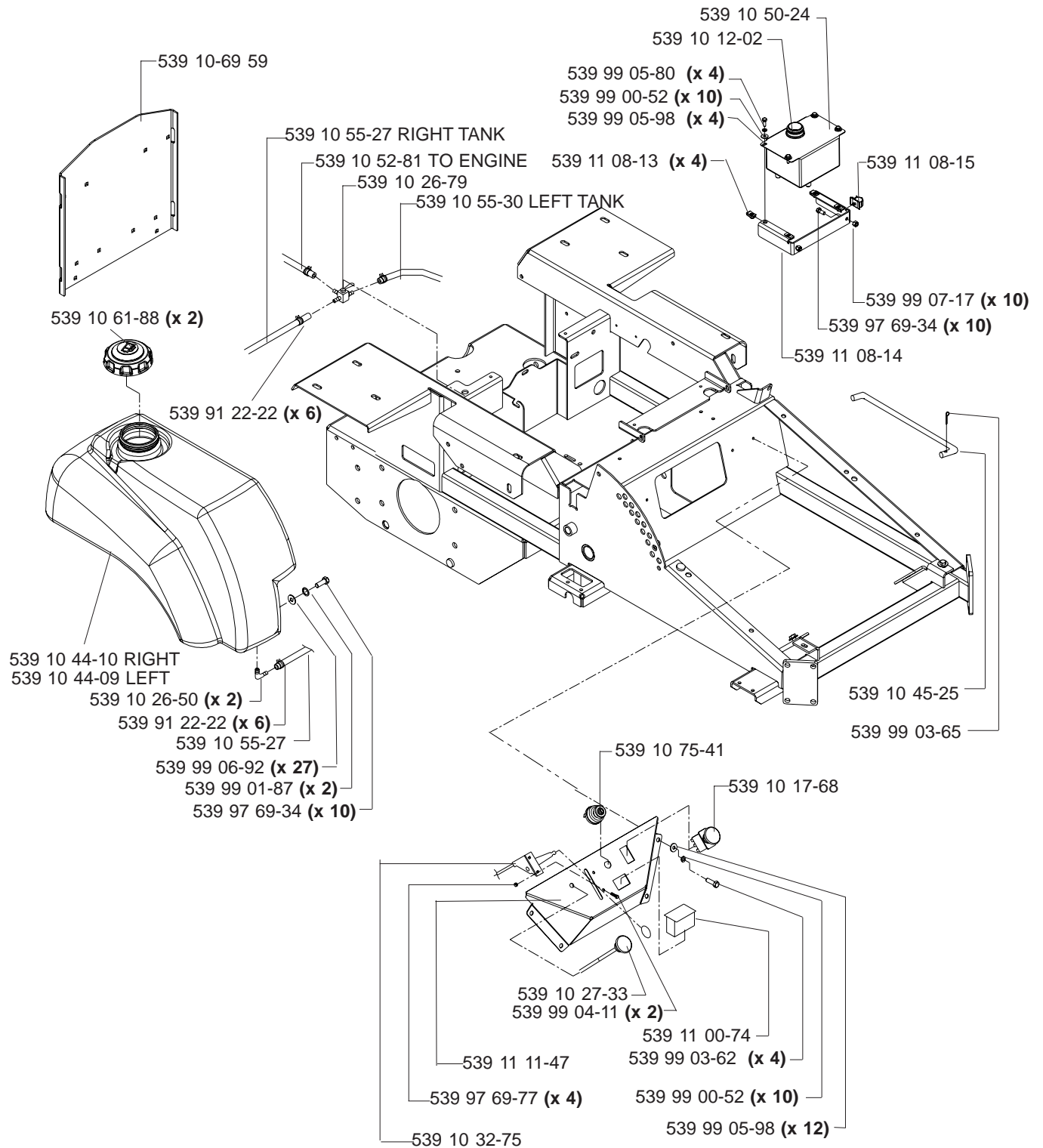

# HYDRAULIC ASSEMBLY (TL)

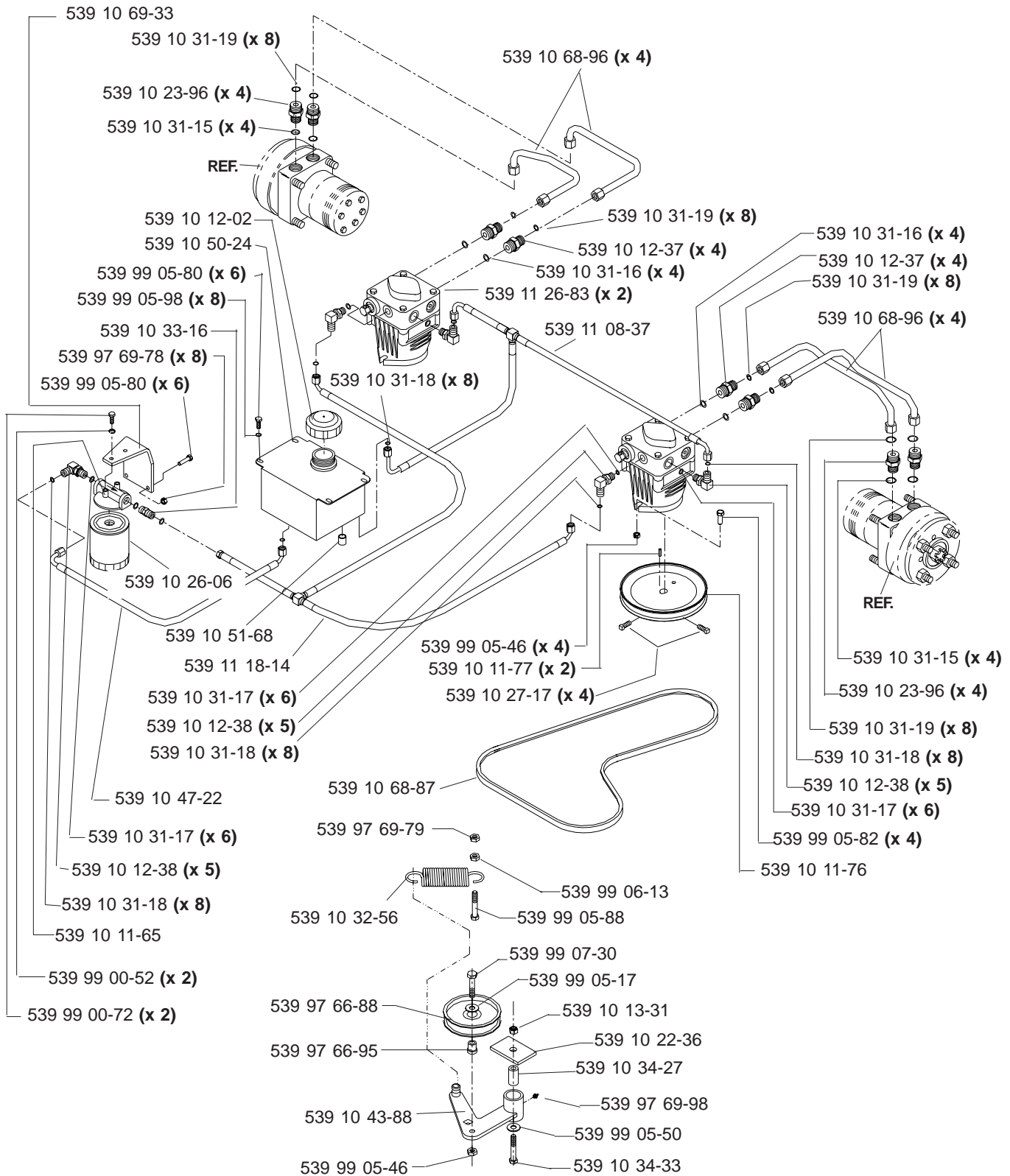

# SEAT ASSEMBLY

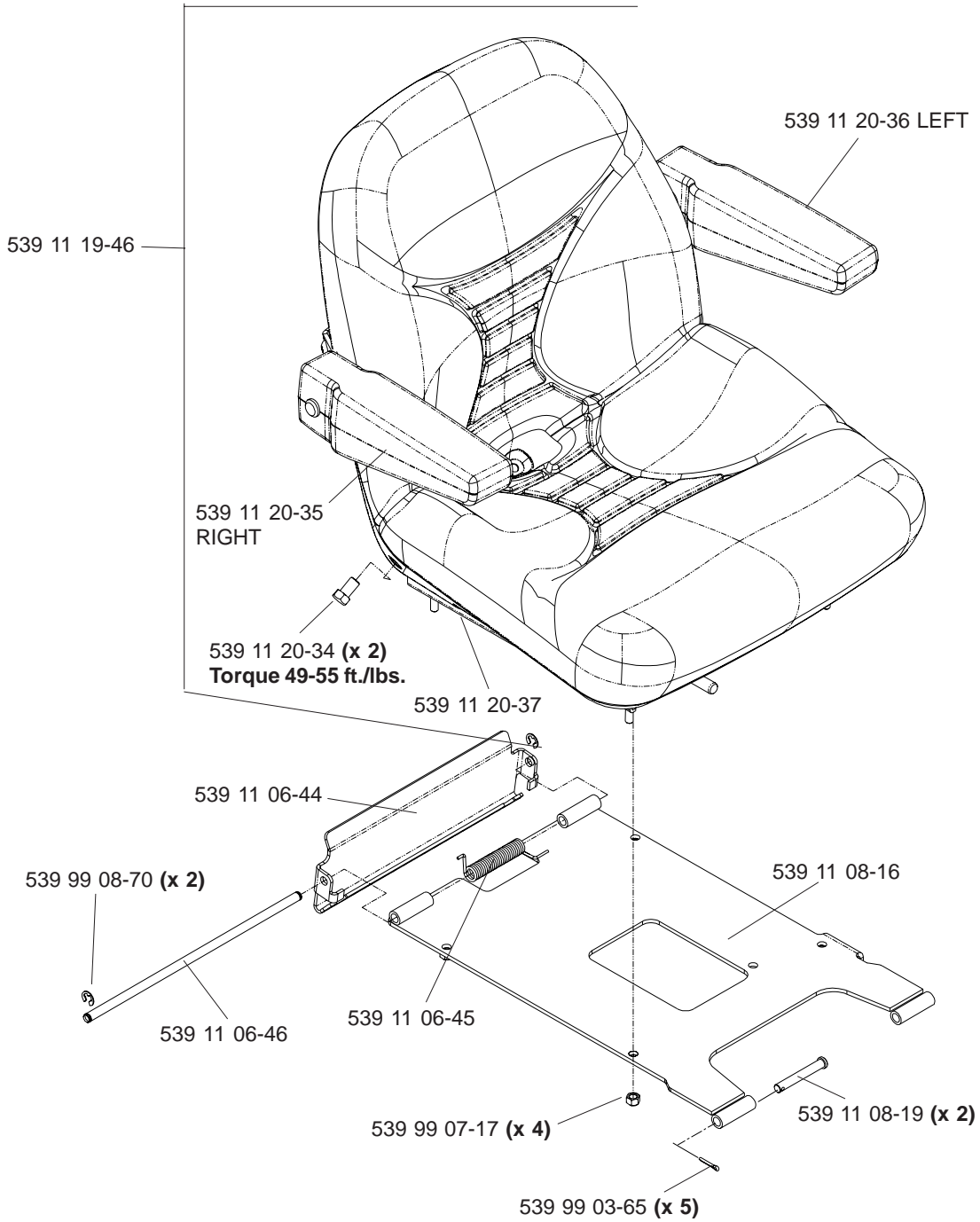

539 10 87-45 ..... 1 ..... SWITCH/SNAP MOUNT KIT (NOT SHOWN)

# KAWASAKI 21 HP ENGINE ASSEMBLY

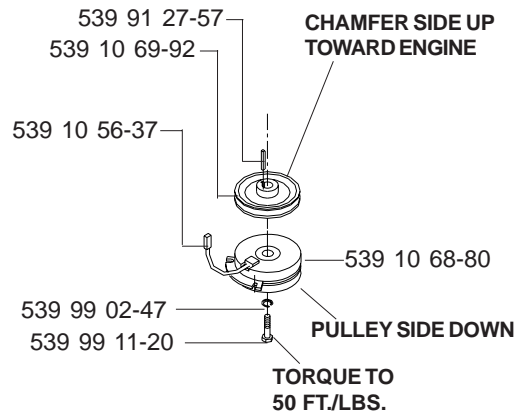
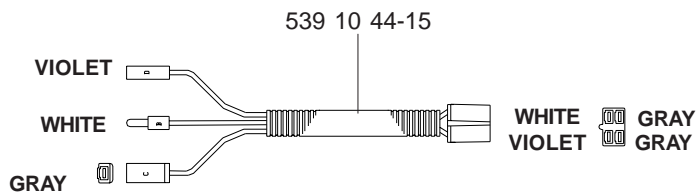
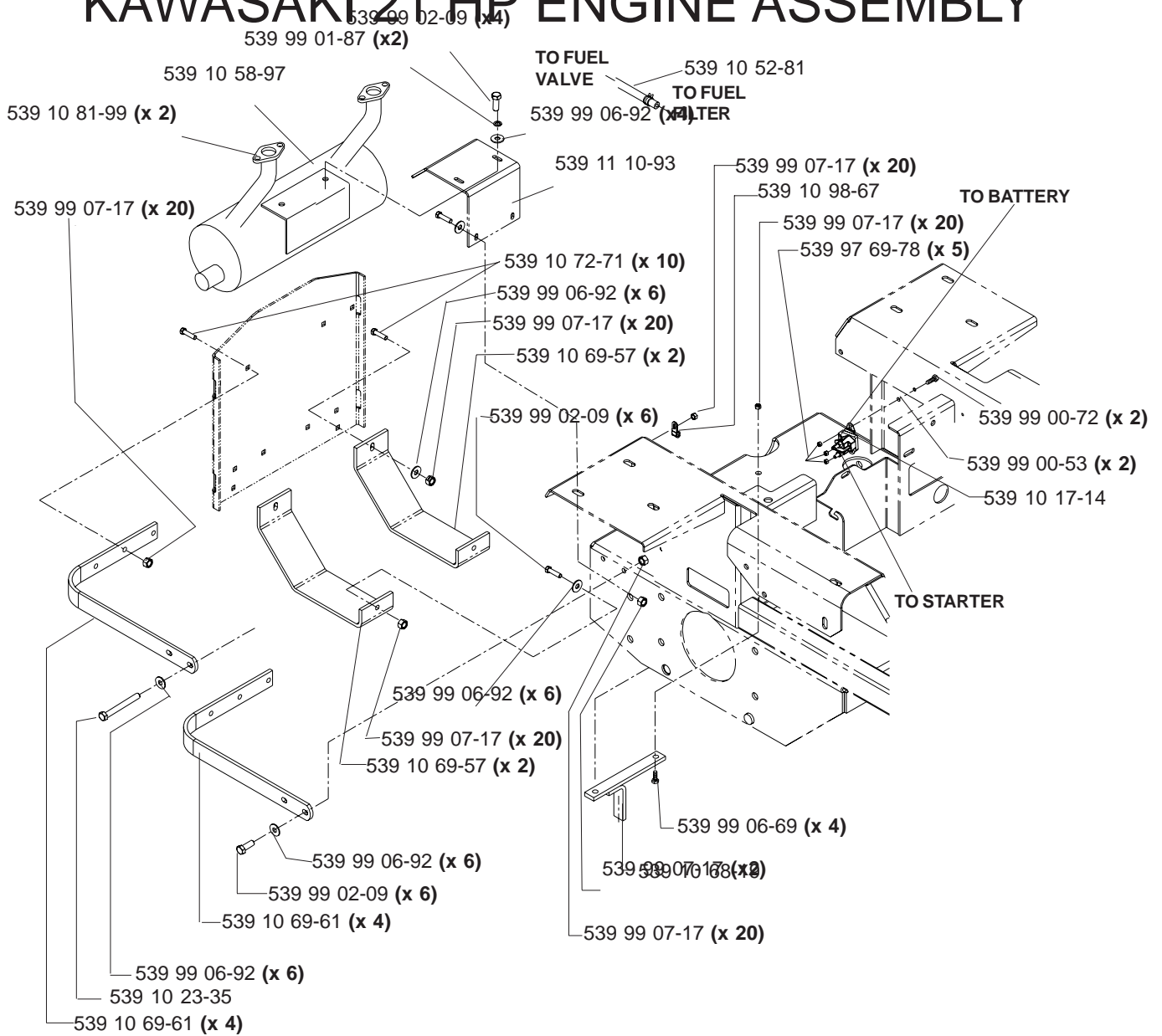

**NOT SHOWN:**

- 539 10 27-57 CABLE, POSITIVE
- 539 10 27-59 INSULATOR

# MOTION CONTROL ASSEMBLY

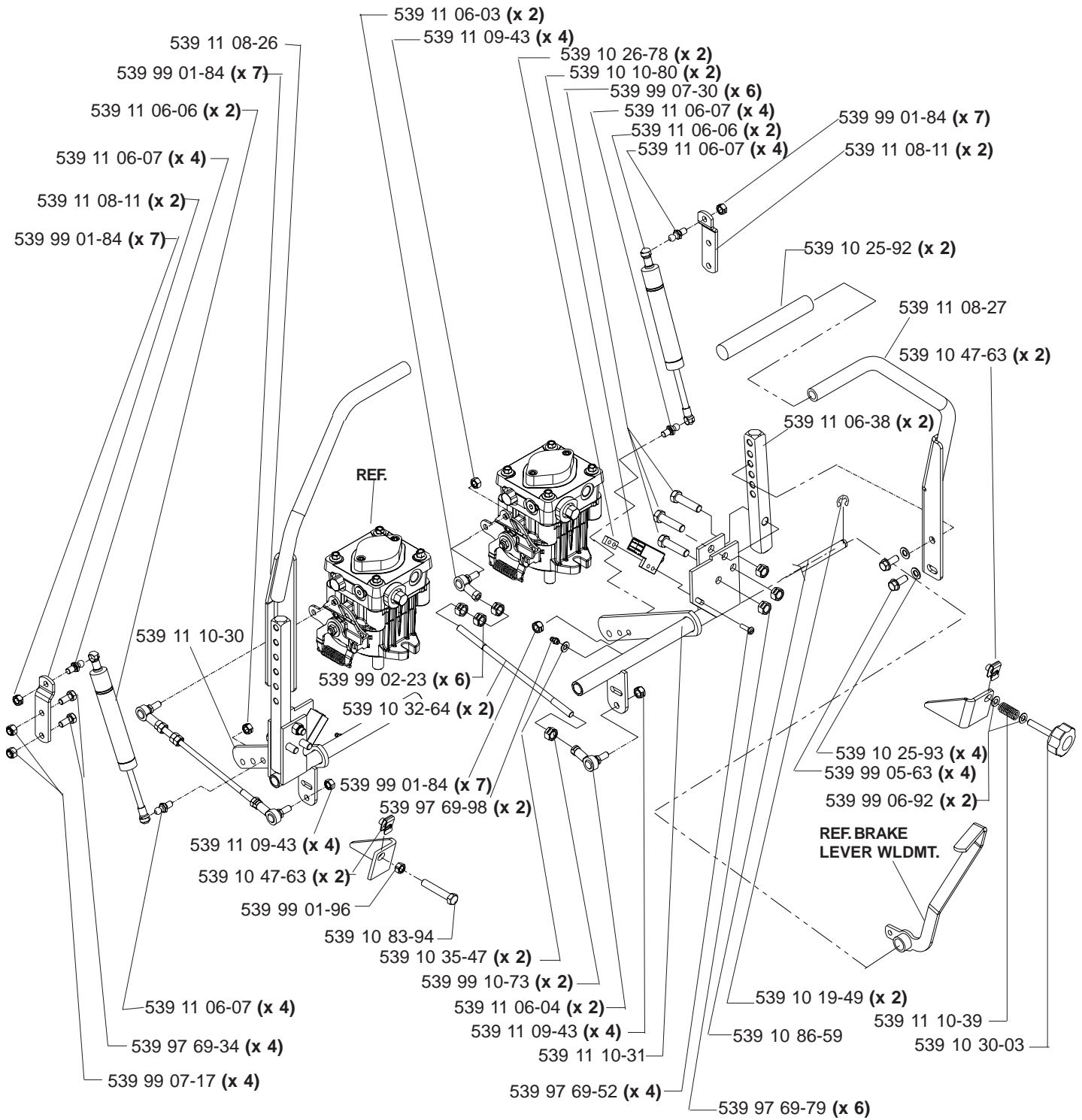

# PARK BRAKE ASSEMBLY (TL)

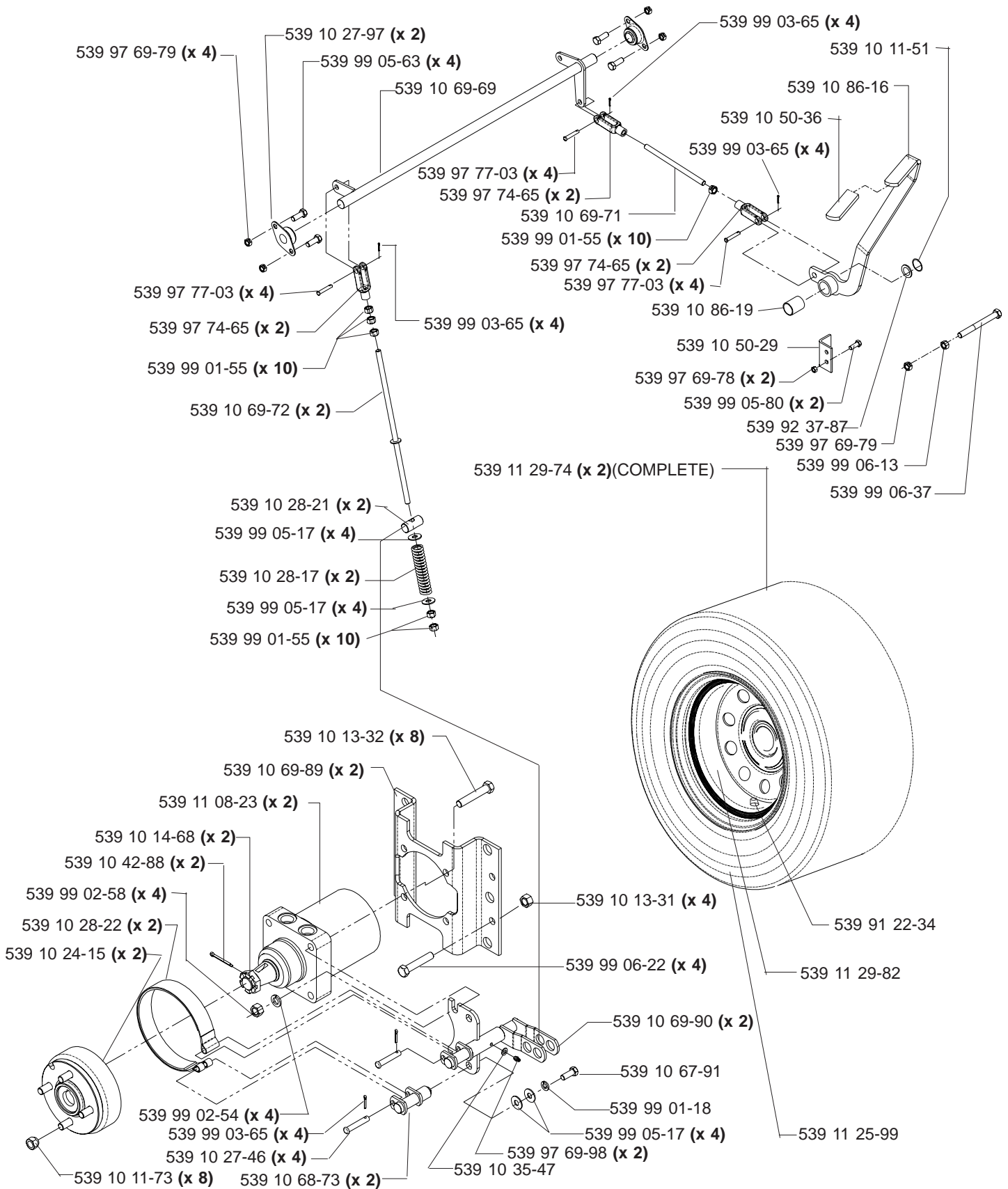

# CASTER ARM

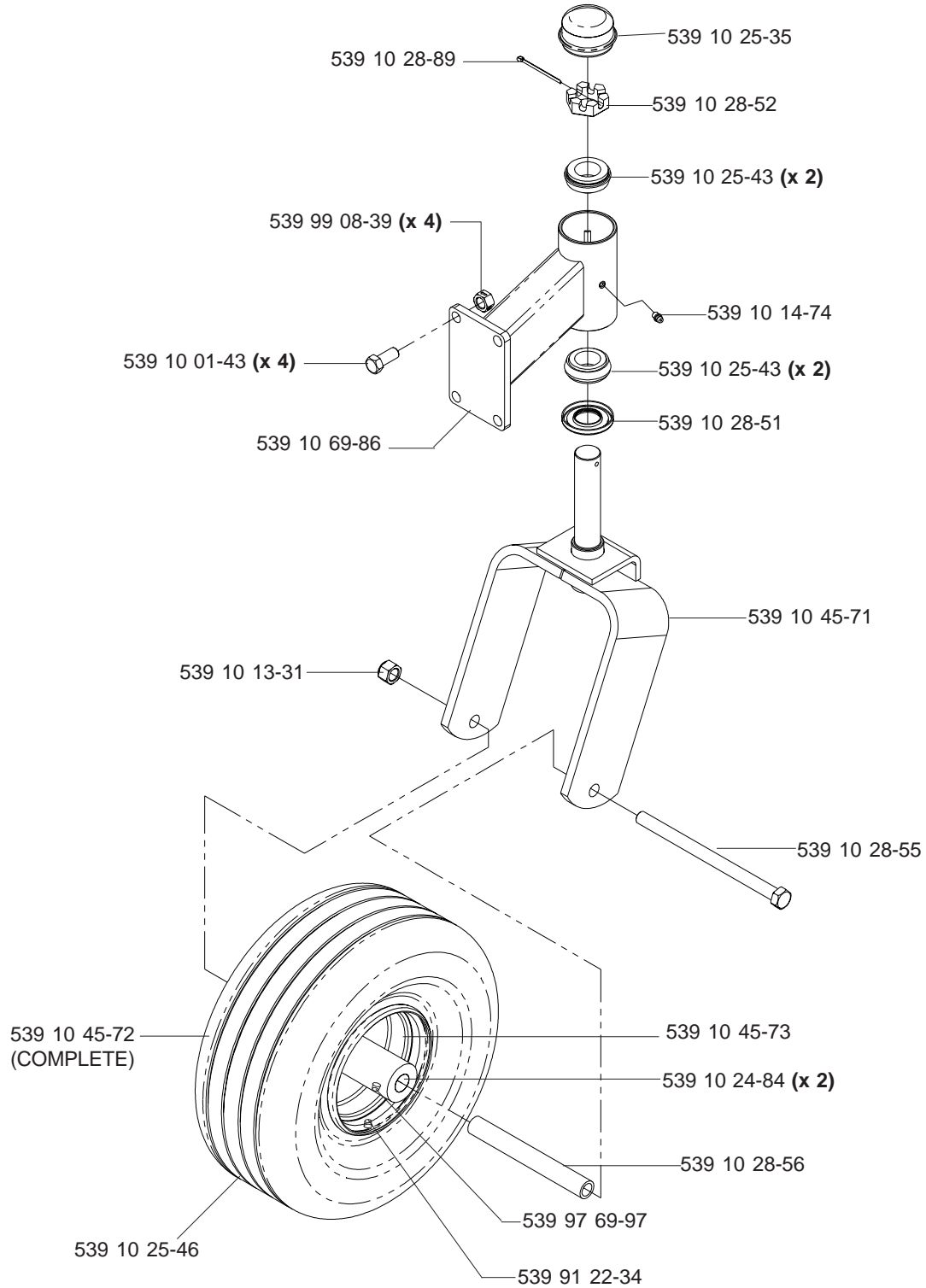



# DECK LIFT ASSEMBLY

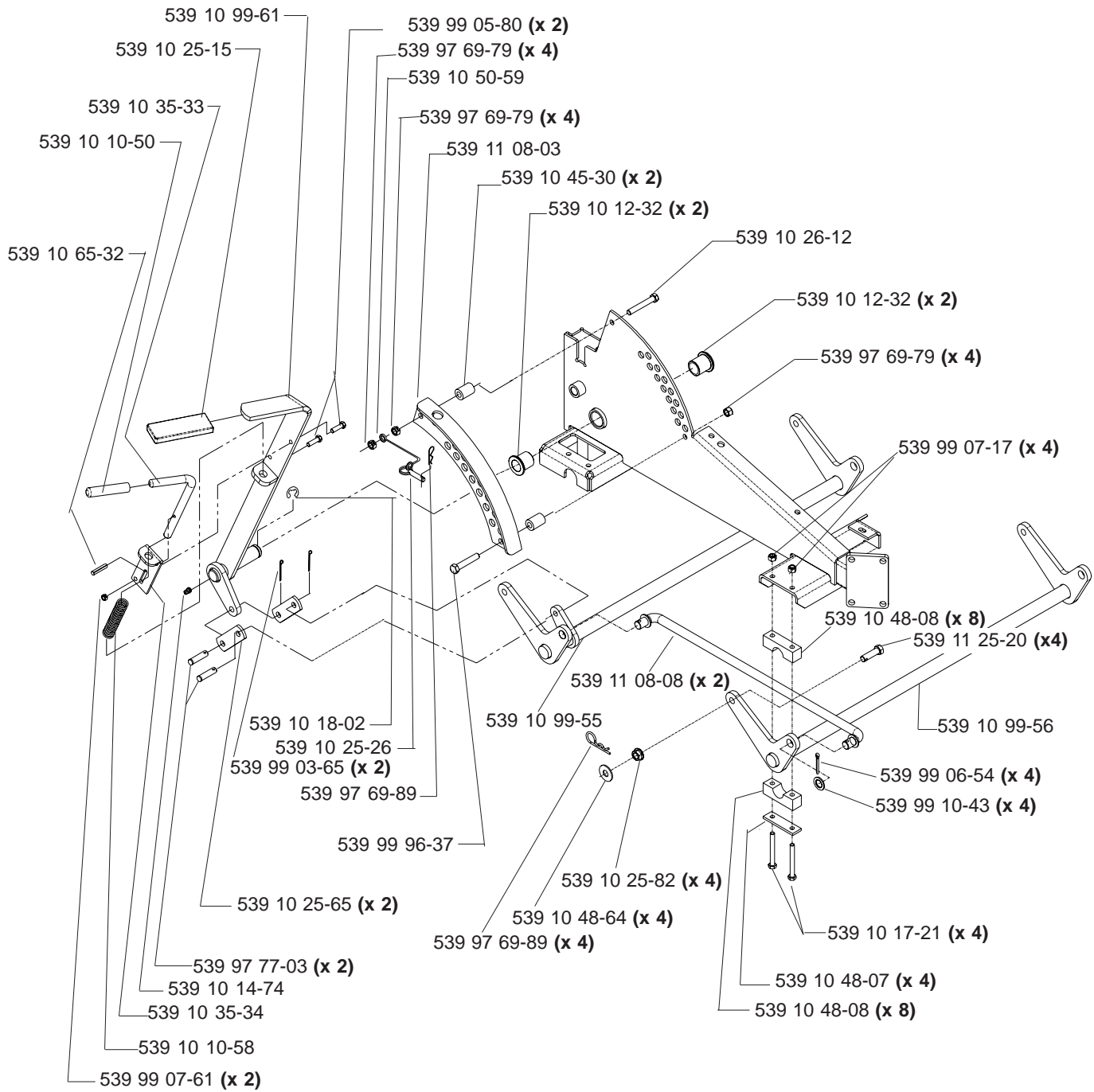

# WIRING ASSEMBLY

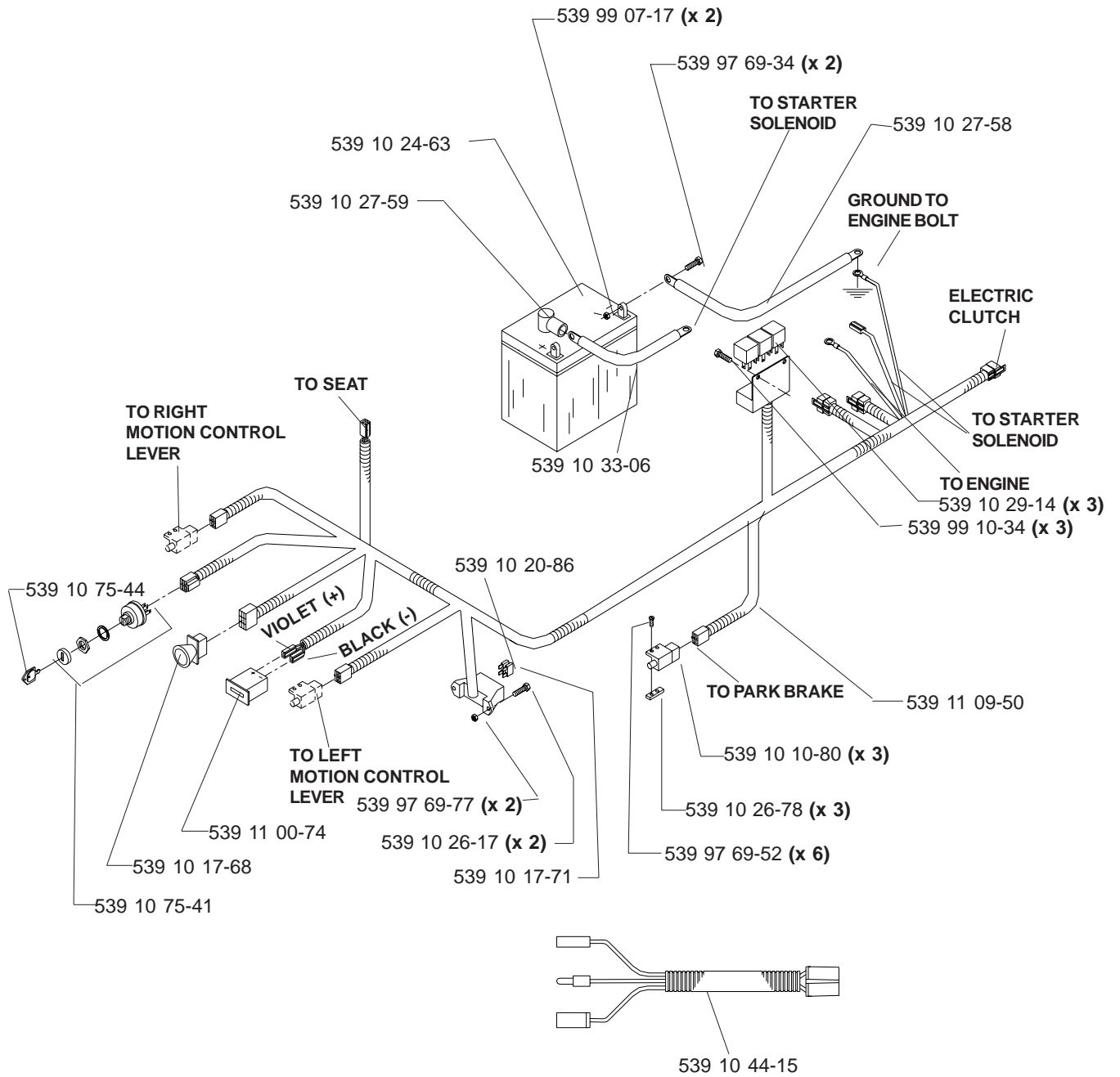

# DECALS

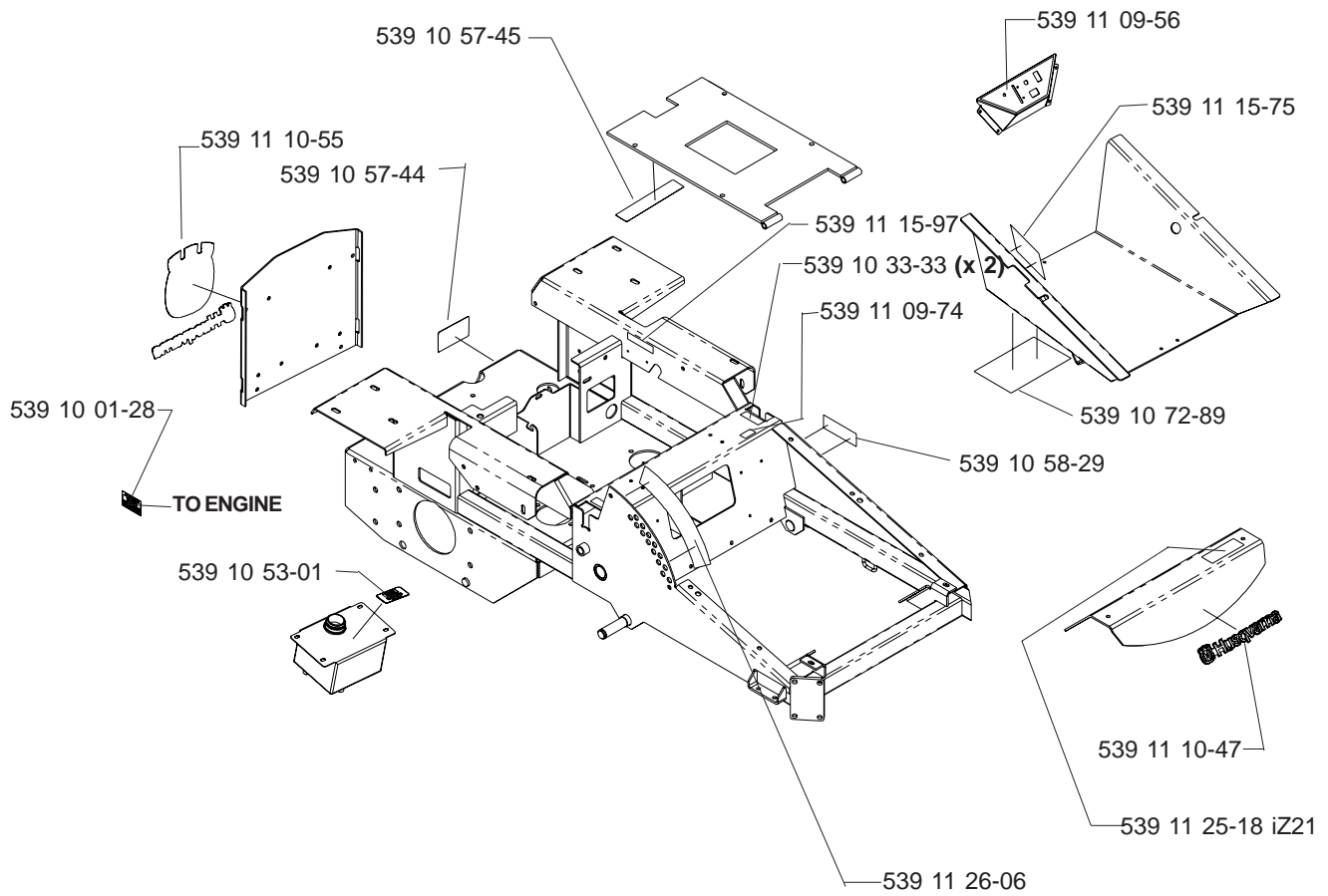

## NOT SHOWN:

- 539 10 26-70 DECAL, FUEL VALVE
- 539 11 29-76 DECAL, CE 968999306
- 539 10 99-09 DECAL, HUSQVARNA, SEAT

# LIFT PEDAL

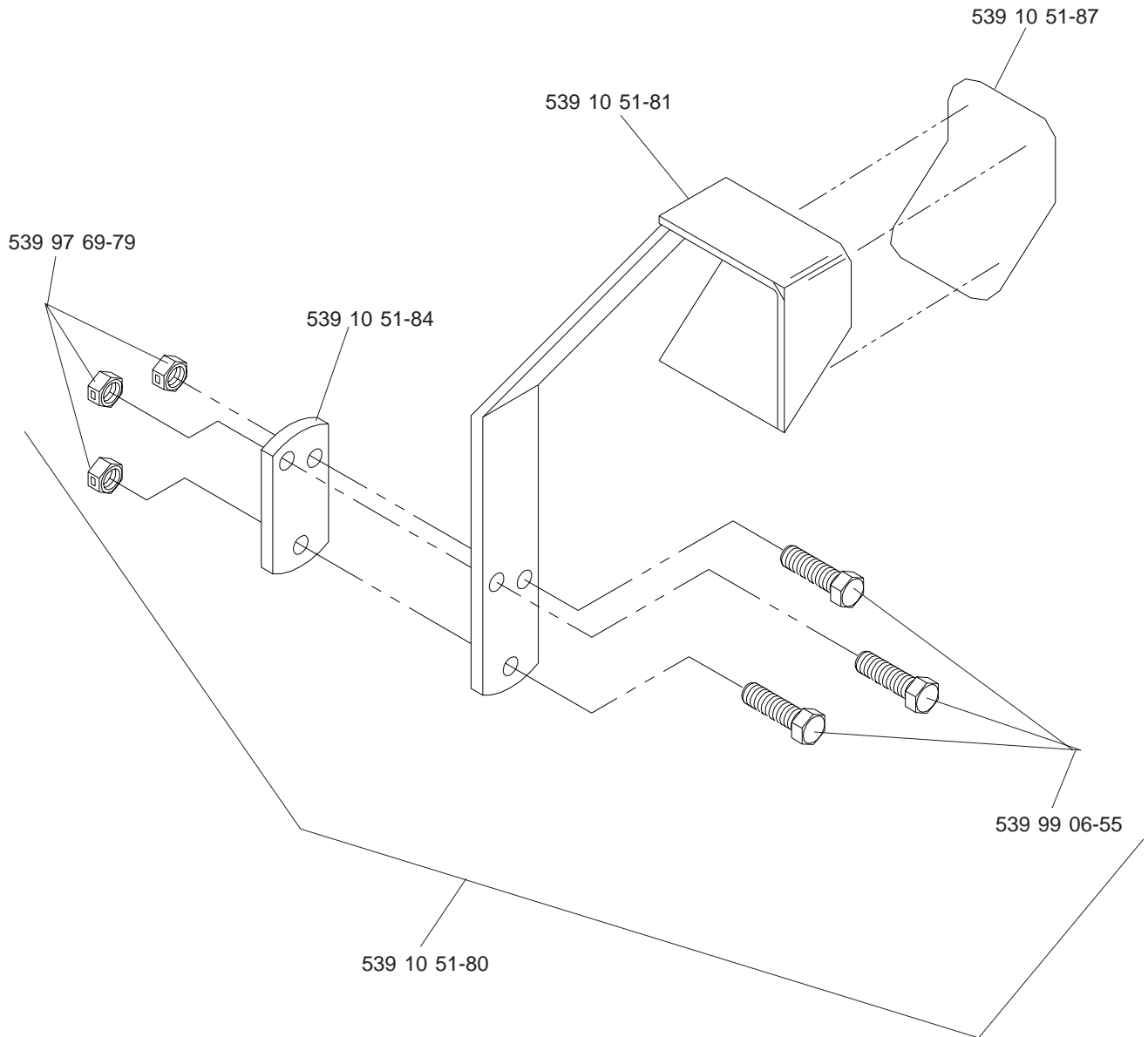

# DEBRIS GUARDING

