

RYOBI 1/2 INCH HAMMER DRILL - MODEL NUMBER HD500

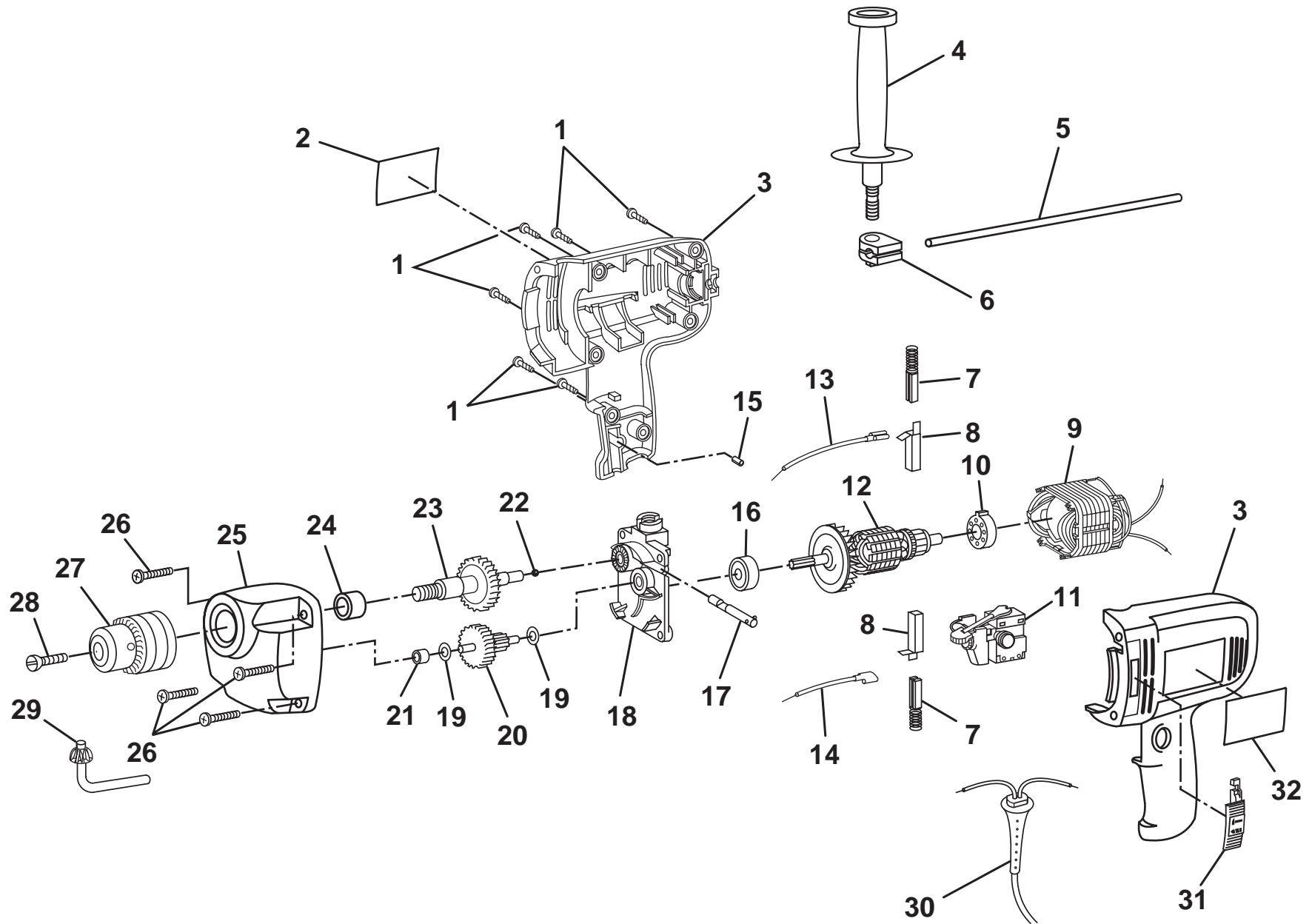

WARNING: IMPROPER REPAIR OF A DOUBLE INSULATED TOOL CAN RESULT IN DAMAGES TO THE DOUBLE INSULATION SYSTEM POSSIBLY CAUSING ELECTRICAL SHOCK OR ELECTROCUTION. ANY REPAIRS REQUIRING DISASSEMBLY OF YOUR TOOL REQUIRES SAFETY TESTING AND SHOULD ONLY BE PERFORMED BY A RYOBI FACTORY SERVICE CENTER. FOR THE REPAIR CENTER NEAREST YOU CALL 1-800-525-2579 IN THE UNITED STATES OR 1-800-265-6778 IN CANADA.

RYOBI 1/2 INCH HAMMER DRILL - MODEL NUMBER HD500

The model number will be found on a plate attached to the motor housing. Always mention the model number in all correspondence regarding your **1/2 INCH HAMMER DRILL** or when ordering repair parts.

PARTS LIST

KEY NO.	PART NUMBER	DESCRIPTION	QUAN.	KEY NO.	PART NUMBER	DESCRIPTION	QUAN.
1	968702-009	SCREW (#8-16 X 5/8 IN. PAN HD.)	6	18	972780-002	BEARING PLATE W/BEARINGS (INCLUDES KEY NO. 16)	1
2	974157-001	DATA PLATE	1	19	931744-063	WASHER	2
3	974153-001	HOUSING ASSEMBLY	1	20	968308-037	GEAR AND PINION	1
4	972895-006	AUXILIARY HANDLE	1	21	990962-001	SLEEVE BEARING	1
5	886165-000	DEPTH GAGE ROD	1	22	703774-005	BALL	1
6	973825-001	CLAMP ROD	1	23	968308-036	GEAR AND SPINDLE ASSEMBLY	1
7	968304-044	BRUSH ASSEMBLY	2	24	990963-001	SLEEVE BEARING	1
8	990839-001	BRUSH TUBE	2	25	974166-001	GEAR HOUSING W/BEARINGS (INCLUDES KEY NOS. 21 AND 24)	1
9	968307-118	FIELD ASSEMBLY	1	26	968703-013	SCREW (#8-32 X 7/8 IN. PAN HD. T.F.)	4
10	611135-005	SLEEVE BEARING	1	27	973869-001	1/2 IN. CHUCK	1
11	974918-001	SWITCH	1	28	613150-003	SCREW (5/16-24 X 7/8 IN. FIL. HD. LEFT HAND)	1
12	968306-124	ARMATURE	1	29	606858-001	CHUCK KEY	1
13	974190-005	YELLOW LEAD	1	30	970105-021	CORD ASSEMBLY	1
14	974190-004	RED LEAD	1	31	972923-002	ADJUSTMENT BUTTON	1
15	623019-003	RUBBER PLUG	1	32	974156-001	LOGO PLATE	1
16	968305-010	BALL BEARING (NTN#608ZZ/1E)	1		972000-312	OWNER'S MANUAL	
17	974164-001	ADJUSTMENT ROD W/PIN	1				