

RYOBI 1/2 in. HAMMER DRILL – MODEL NUMBER HD420

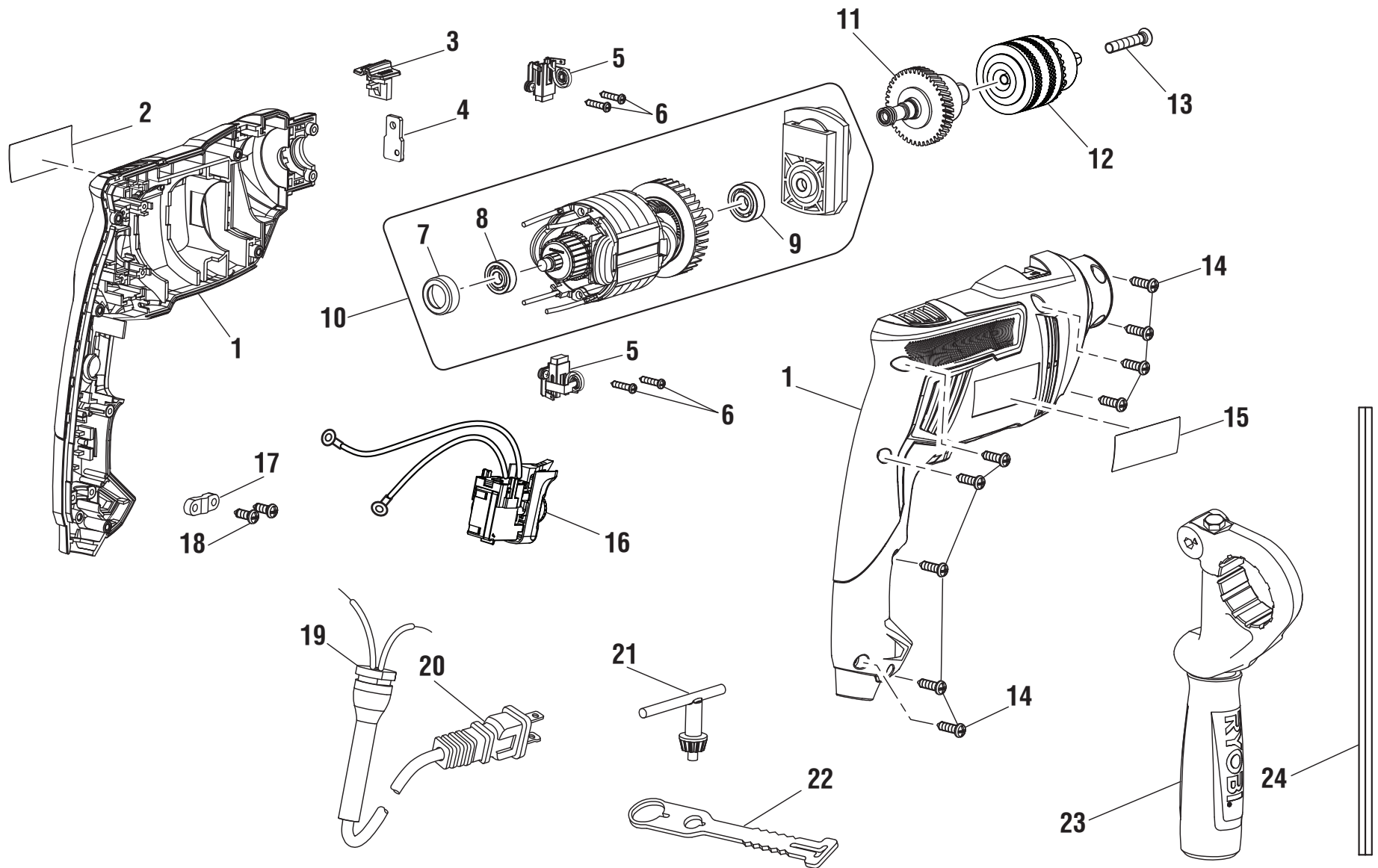

WARNING: Improper repair of a double insulated tool can result in damage to the double insulation system possibly causing electrical shock or electrocution. Any repairs requiring disassembly of your tool requires safety testing and should only be performed by a Ryobi Authorized Service Center. For the service center nearest you call 1-800-525-2579.

RYOBI 1/2 in. HAMMER DRILL – MODEL NUMBER HD420

The model number will be found on a label attached to the motor housing. Always mention the model number in all correspondence regarding your **HAMMER DRILL** or when ordering parts.

PARTS LIST

KEY NO.	PART NUMBER	DESCRIPTION	QTY	KEY NO.	PART NUMBER	DESCRIPTION	QTY
1	039803001007	Housing Assembly (Inc. Key Nos. 2 and 15).....	1	14	039803001016	Screw (4.2 x 16 mm, Torx Hd.)	9
2	039803001009	Logo Label.....	1	15	039803001011	Data Label.....	1
3	039803001018	Mode Shift Button.....	1	16	039803001033	Switch Assembly	1
4	039740003029	Impact Plate.....	1	17	039140001067	Cord Clamp	1
5	039803001020	Brush Assembly.....	1	18	039140001066	Screw (M4.2 x 14 mm, Pan Hd.).....	2
6	039740003024	Screw (M2.9 x 16 mm, Pan Hd.).....	4	19	039140001070	Bend Relief	1
7	039740003019	Bearing Cover	1	20	039803001013	Power Cord.....	1
8	039140001048	Ball Bearing (607-2Z)	1	21	039171001014	Chuck Key	1
9	039740003015	Ball Bearing (608-2RZ).....	1	22	039171001015	Chuck Key Holder.....	1
10	039803001004	Motor Assembly (Inc. Key Nos. 7-9)	1	23	039803001034	Auxiliary Handle Assembly	1
11	039740003001	Output Spindle Shaft and Gear Assembly	1	24	039171001002	Depth Stop Rod.....	1
12	039171001006	1/2 in. Chuck.....	1		NOT SHOWN:		
13	039140001012	Chuck Screw (M6 x 25 mm, Special, Left Hand Threads)	1		990000163	Operator's Manual	
					3-6-13 (Rev:02)		