



BOSCH

Angle Grinder

GWS 670 | 3 601 C75 487

Table of Content

Spare parts list.....	2
Illustration - Type.....	4

Spare parts list

Item	Part Number	Description
1	1 619 P09 772	Motor Housing
3/50	1 619 P10 684	Fan
4	1 607 200 179	On-Off Switch
5	1 604 460 263	Power supply cord H05 W-F CN 2,65m 2 x 0,75mm
6	2 600 703 012	Grommet Ø6,5-Ø6,9x95 MM
7	1 601 302 017	Fastening Clamp
12	1 619 P07 647	Suppression Filter
13	1 619 P00 456	Ball Bearing 7x19x6 MM
14	1 619 P00 455	Ball Bearing
16	1 619 P01 811	Brush Holder
17	1 604 652 013	Spiral Spring
18	1 604 611 031	Compression Spring
22	1 602 319 009	Adjusting Slide
23	1 619 P02 762	Switch Button BLACK
25	1 619 P20 072	Housing Cover
26	1 600 502 023	Intermediate Ring
27	1 600 206 025	Rubber Ring
29	1 600 591 023	Air-Deflector Ring
32	1 619 P20 124	Grinding Spindle
33	1 600 210 041	O-Ring 42,0x1,1 MM
35	1 600 136 016	Shim 0,1 MM THICK
35	1 600 136 017	Shim 0,2 MM THICK
37	1 600 100 033	Cover Disc
45	2 915 011 007	Hex Nut DIN 934-M6-8-A
47	2 609 110 052	Special Screw
48	1 619 P00 220	Torx Oval-Head Screw 3x10
49	1 603 435 068	Thread-forming tap. Screw DIN 7500, M4x10, SR10.2
50	2 910 611 020	Tapping Screw DIN 7981-ST3,9x19-C-H
55	2 910 611 022	Tapping Screw DIN 7981-ST3,9x25-C-H
80	1 619 P09 390	Cover Disc
802	1 619 P12 316	Field 220-240V
803	1 619 P01 844	Armature 220-240V
810	1 619 P07 571	Carbon-Brush Set
821	1 605 806 466	Gear Housing

Spare parts list

Item	Part Number	Description		
826	1 619 P15 943	Bevel Gear Set		
828	1 619 P02 708	Bearing Flange	BLACK	
840	1 607 000 298	Push-Button	BLACK	
841	1 600 910 018	Needle bearing	Ø8xØ12x8 MM	
857	2 910 641 081	Oval-Head Screw	DIN7985-M3,5x5-4.8-H	
650/10	1 602 025 09T	Auxiliary Handle		
650/20	1 619 P09 976	Round Nut With 2 Holes		
650/30	1 619 P20 114	Pin-Type Face-Wrench		
650/50	1 619 P12 159	Clamping-Flange	Ø22,3xØ42 MM	
651	1 619 P02 838	Protective Cover	Ø 100 MM	BLACK
894	1 615 430 020	Grease Tube	225 ML	
895	1 605 430 003	Grease Tube	225 ML	

Illustration - Type - E

3 601 C75 681
Stand
Issue } 20-03-17

Fig. /Abb. 1

Gerad - Verzahnung

- Vor Demontage des Ankers Kohlebürsten 5mm zurückziehen !
Before the armature is removed the carbon brushes must be withdrawn by at least 5mm !

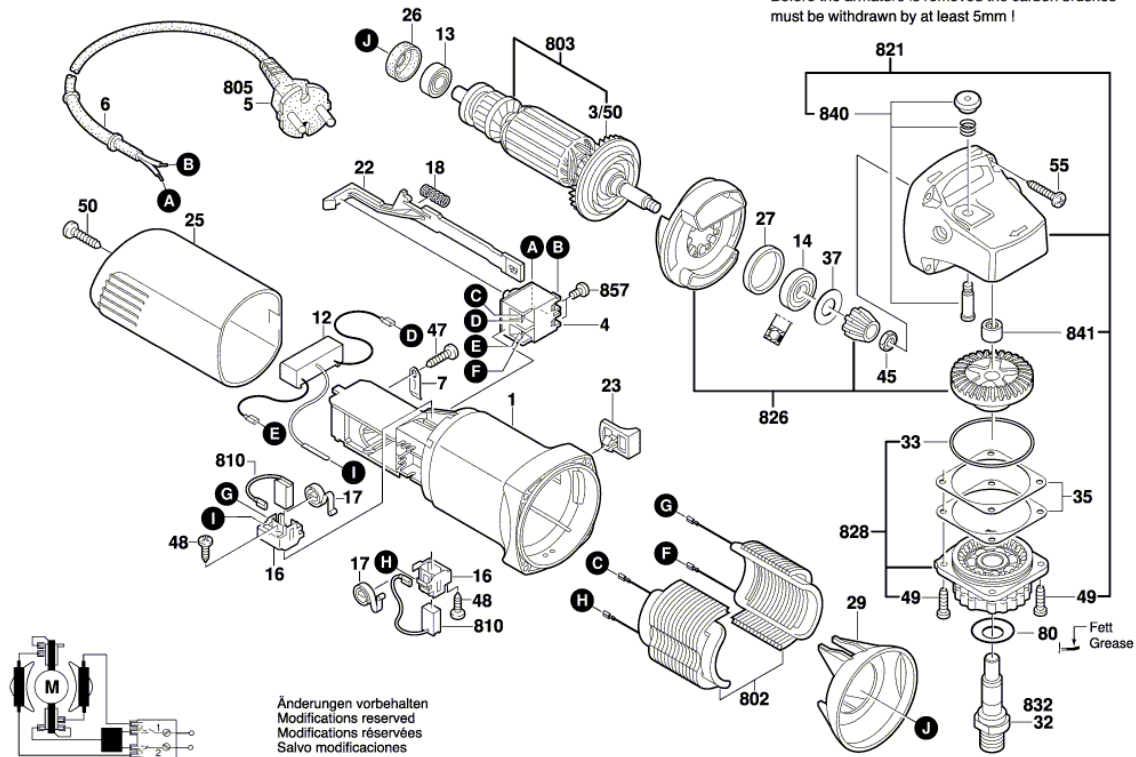
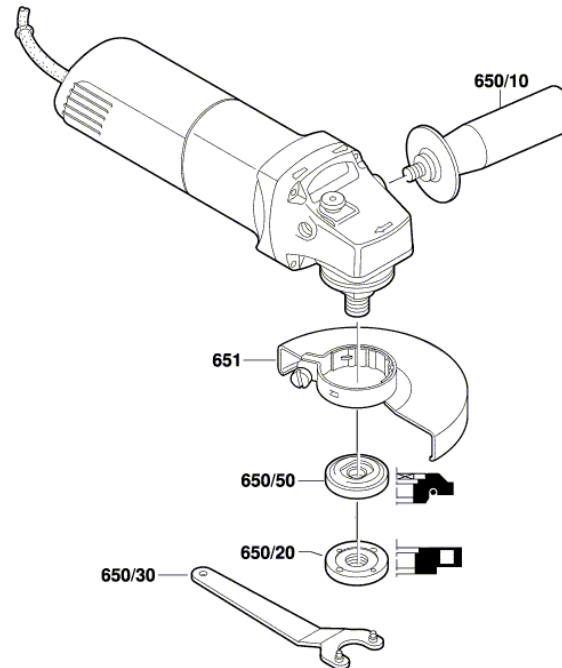

Illustration - Type - E

3 601 C75 681
Stand } 20-03-17 Fig. /Abb. 2
Issue }



Änderungen vorbehalten
Modifications reserved
Modifications réservées
Salvo modificaciones