



BOSCH

Rotary Hammer

GBH 2-24 RE | 3 611 B72 080

Table of Content

Spare parts list.....	2
Illustration - Type.....	5

Spare parts list

Item	Part Number	Description
2	1 619 P11 998	Field 230V
3/5	1 619 P12 021	Fan
4	1 607 200 32D	Switch
5	1 614 460 090	Power supply cord H07 RN-F CN 4,15m 2 x 1,0mm
6	1 600 703 034	Grommet Ø7,3-Ø8,6x66 MM
12	1 614 465 011	Suppression Filter
13	1 610 905 025	groove ball bearing 7x19x6
14	1 619 P15 694	Ball Bearing
16	1 619 P16 871	Brush Plate
17	1 616 B10 337	Switch Contact
22	1 616 312 004	Cylindrical Gear
27	1 610 311 018	Striker
28	1 613 124 081	Striker Pin
29	1 613 105 012	Piston Pin
31	1 610 913 016	Needle-Roller Assembly
32	1 612 026 157	Clamp Handle BLACK
32/46	1 619 P09 571	Driver Pin
32/49	1 612 026 035	Switch Button RED
32/76	1 610 210 046	O-Ring 10,5x2,7 MM
32/83	1 614 611 006	Compression Spring
33	1 610 590 014	Holding Jacket
34	1 619 P12 280	Supporting Disc
35	1 616 B10 325	Plain bearing
36	1 615 808 106	Bearing Holder
37	1 613 100 019	Straight Pin DIN6325-2,5x12-RIKO
38	1 610 190 048	Catch Disk
41	1 619 P12 191	Housing Cover
42	1 610 102 073	Thrust Ring
44	1 610 508 034	Protective Cap
45	1 619 P12 192	Air-Deflector Ring
46	2 608 670 714	Guide Bushing
49	1 615 700 044	End Shield
50	1 614 611 020	Compression Spring
54	1 610 502 016	Rubber Bushing

Spare parts list

Item	Part Number	Description
55	1 619 P18 144	O-Ring
56	1 610 210 187	O-Ring
57	1 610 210 068	O-Ring 24,0x2,5 MM
58	1 610 210 178	O-Ring
59	1 610 283 035	Rotary shaft lip seal
60	1 610 210 176	O-Ring 9,0x3,5 MM
63	1 610 910 063	Needle bearing Ø30xØ37x12 MM
64	1 619 P12 278	Supporting Disc
66	1 610 202 021	Plain bearing
68	1 610 283 017	Rotary shaft lip seal
70	1 903 230 013	Ball DIN 5401-Ø7MM-III-ST
71	1 610 101 011	Shim washer 1,2 MM THICK
72	1 604 601 027	Retaining ring
74	1 614 601 027	Retaining ring
75	1 610 101 629	Retaining Washer
76	1 613 435 022	Thread-forming tap. Screw
77	2 603 490 024	Torx Oval-Head Screw 4x25
79	1 613 435 023	Thread-forming tap. Screw
80	1 619 P08 803	Thread-forming tap. Screw
81	1 613 435 014	Torx Oval-Head Screw M5x16-TORX,T25 SILVER
82	1 614 601 034	Retaining ring
83	1 604 601 028	Retaining ring A22 DIN 7993
87	2 916 540 012	Retaining ring DIN 7993-A22
101	1 614 449 014	Connecting Cable
102	1 614 449 015	Connecting Cable
103	1 613 435 034	Lens Head Screw 3x10 ST
105	1 614 611 021	Compression Spring
801	1 619 P13 454	Motor Housing BLUE
803	1 619 P13 450	Armature 230V
807	2 601 035 001	Cable Clip
811	1 617 000 525	Carbon-Brush Set 220 V / 127 V
820	1 619 P13 451	Intermediate Flange
821	1 619 P13 452	Pipe
823	1 619 P13 456	Toothed Shaft

Spare parts list

Item	Part Number	Description
824	1 619 P13 457	Toothed Shaft
826	1 617 000 557	Hammer Piston
828	1 619 P13 453	Striker Pin
829	1 619 P13 455	Pipe
830	1 615 819 028	Drive bearing
840	1 619 P13 458	Gear Housing
843	1 619 P13 459	Protective Cap
861	1 619 P13 460	Switching Element
864	1 619 P13 461	Supporting Disc
866	1 614 611 022	Plain bearing
651	1 613 001 009	Depth-Gauge SW 6x210 MM
691	1 615 438 409	Lock for 1 615 438 486+...358+...367
691	1 615 438 426	Lock for 1 615 438 395
691	1 615 438 431	Lock for 1 615 438 429 + 1 615 438 430
822	1 602 025 08X	Auxiliary Handle
822/120	1 602 025 07H	Auxiliary Handle
822/124	1 611 316 021	Clamping Band Ø50 MM
822/125	1 613 490 002	T-Head Bolt M8x40 MM
822/802	1 617 000 475	Support clamp
870	1 613 523 011	Drill Chuck Shank 1/2", SDS-Plus
870/2	2 603 421 207	Countersunk-Head Screw M6x27-KØ11 LEFTHAND THREADS
871	1 608 571 088	Chuck
872	2 607 950 007	Chuck Wrench SG2
892	1 615 430 001	Grease Tube 225 ML
893	1 615 430 002	Grease Tube 225 ML
894	1 615 430 020	Grease Tube 225 ML
895	1 615 430 019	Oil Reservoir 1000 ML

Illustration - Type - E

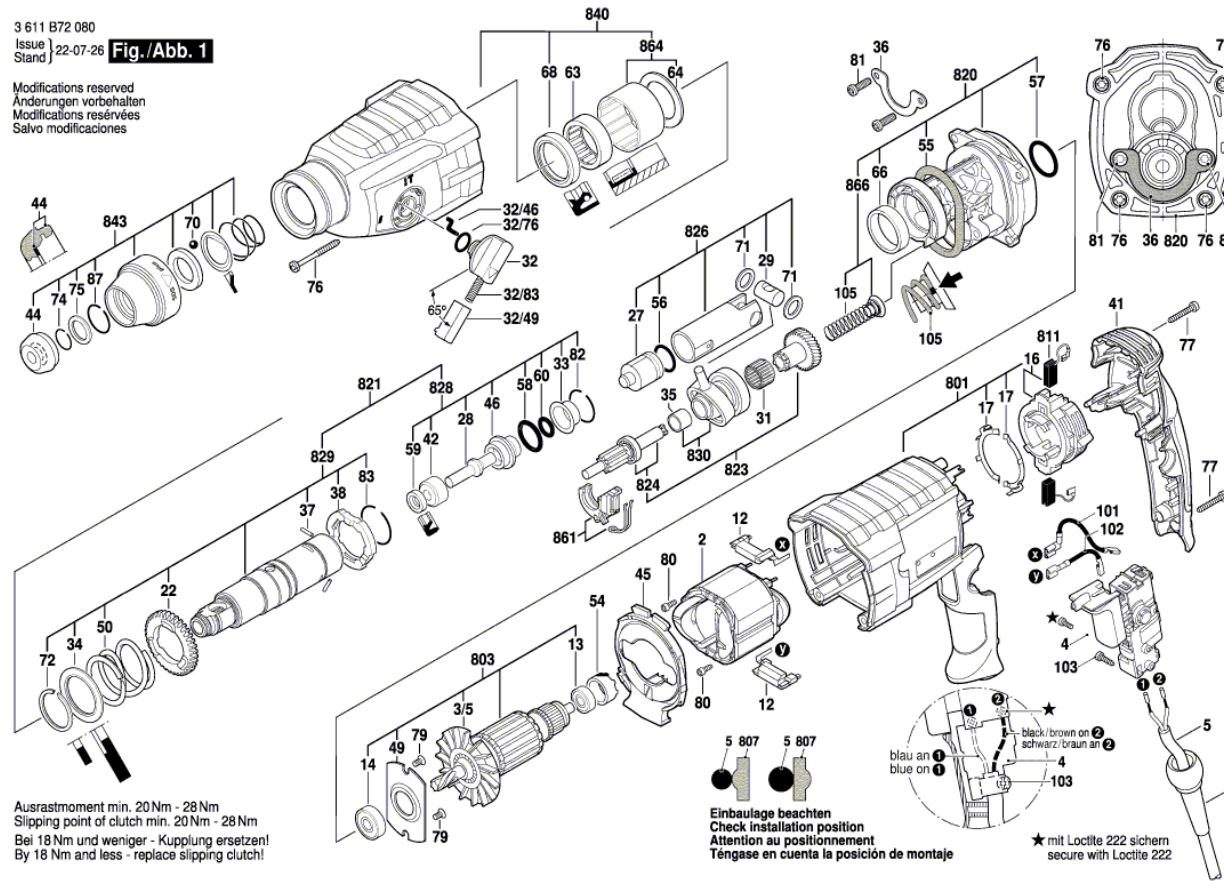
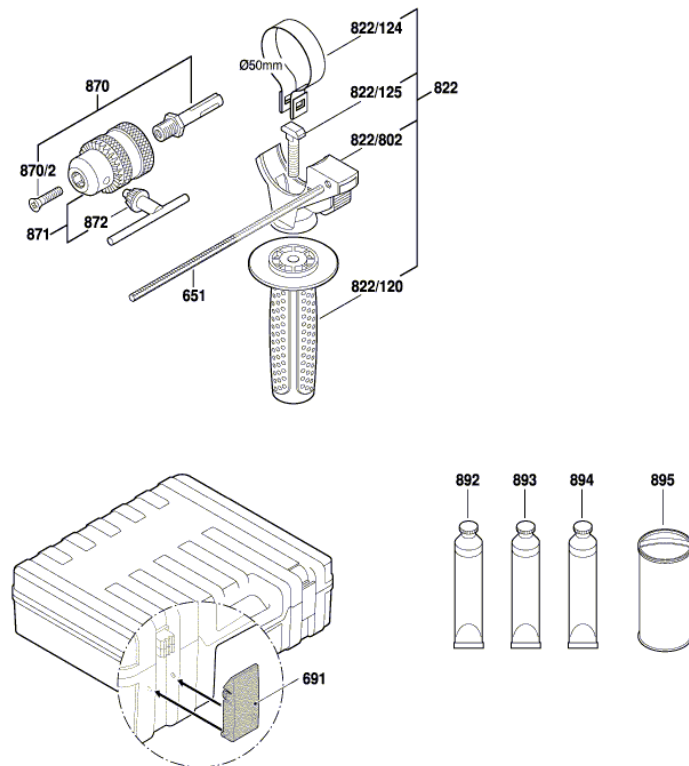

Illustration - Type - E

3 611 B72 080
Issue |
Stand | 15-08-05 **Fig./Abb. 2**



Modifications reserved
Änderungen vorbehalten
Modifications réservées
Salvo modificaciones