

Model GAG06Z Parts List

A = Standard Equipment

O = Circuit Diagram

Item#	Part#	Description	Q'ty Unit
001	8008U5-3	CLEAR LABEL	1 PC.
002	183P78-5	MOTOR HOUSING SET	1 PC.
	C10 263005-3	RUBBER PIN 6	2 PC.
	D10	INC. 41	
003	266326-2	TAPPING SCREW 4X18	5 PC.
004	140G30-2	CAP COMPLETE	1 PC.
	C10 213218-6	O RING 16	1 PC.
	C20 818H48-4	CAP LABEL	1 PC.
005	210023-2	BALL BEARING 627DDW	1 PC.
006	519595-7	ROTOR ASS'Y	1 PC.
	D10	INC. 5	
007	136190-4	GEAR HOUSING COVER ASS'Y	1 PC.
	D10	INC. 8	
008	213445-5	O-RING 26	1 PC.
009	210042-8	BALL BEARING 629LLB	1 PC.
010	226976-5	SPIRAL BEVEL GEAR 10	1 PC.
011	252186-8	HEX. NUT M6	1 PC.
012	136198-8	GEAR HOUSING ASS'Y	1 PC.
	D10	INC. 13-17	
013	412234-7	PIN CAP	1 PC.
014	233072-2	COMPRESSION SPRING 8	1 PC.
015	263002-9	RUBBER PIN 4	1 PC.
016	213960-9	O RING 5	1 PC.
017	256546-6	SHOULDER PIN 4	1 PC.
018	266048-4	TAPPING SCREW 4X40	4 PC.
019	210033-9	BALL BEARING 696ZZ	1 PC.
020	233950-6	RING SPRING 11	1 PC.
021	226862-0	SPIRAL BEVEL GEAR 37	1 PC.
022	962151-6	RETAINING RING R-32	1 PC.
023	211129-9	BALL BEARING 6201DDW	1 PC.
024	213622-9	O RING 45	1 PC.
025	136262-5	BEARING BOX ASS'Y	1
	D10	INC. 24,26,32	
026	213510-0	O RING 36	1 PC.
027	327322-6	SLEEVE 4	2 PC.
028	232490-1	COMPRESSION SPRING 4	1 PC.
029	347641-4	LEVER B	1 PC.
030	911159-7	PAN HEAD SCREW M4X30	2 PC.
031	911138-5	P.H.SCREW M4X20 WITH WR	2 PC.
032	232542-8	SCROW WAVE SPRING 41	1 PC.
033	962105-3	RETAINING RING R-26	1 PC.
034	326670-0	SPINDLE A	1 PC.
035	310515-2	LEAD FLANGE A	1 PC.
036	140N43-5	WHEEL COVER 125L COMPLETE	1 PC.
	C10 813N68-9	CAUTION LABEL	1 PC.
037	224448-4	INNER FLANGE 45B	1 PC.
038	193465-4	LOCK NUT 5/8-45	1 PC.
039	8005T5-8	XGT LOGO LABEL	1 PC.
040	422610-7	DUST COVER	1

041	183P78-5	MOTOR HOUSING SET	1 PC.
	C10 263005-3	RUBBER PIN 6	2 PC.
	D10	INC. 2	
042	140T33-4	SWITCH LEVER COMPLETE	1
043	233263-5	COMPRESSION SPRING 9	1 PC.
044	651083-9	SWITCH C3XA-1PSPM	1 PC.
045	629A00-3	STATOR COMPLETE	1
046	632P65-6	TERMINAL UNIT	1 PC.
047	857H79-8	GAG06 NAME PLATE	1
048	857H85-3	GAG06 SERIAL NO. LABEL	1
049	620D30-5	DIAL CIRCUIT	1
050	8015J1-9	INDICATION LABEL	1
A01	158237-4	GRIP 36 COMPLETE	1 PC.
A02	A-95962	INOX GRINDING WHEEL 125MM	1 PC.
A03	782424-9	LOCK NUT WRENCH 28	1 PC.
E01	805C42-5	CAUTION LABEL	1 PC.

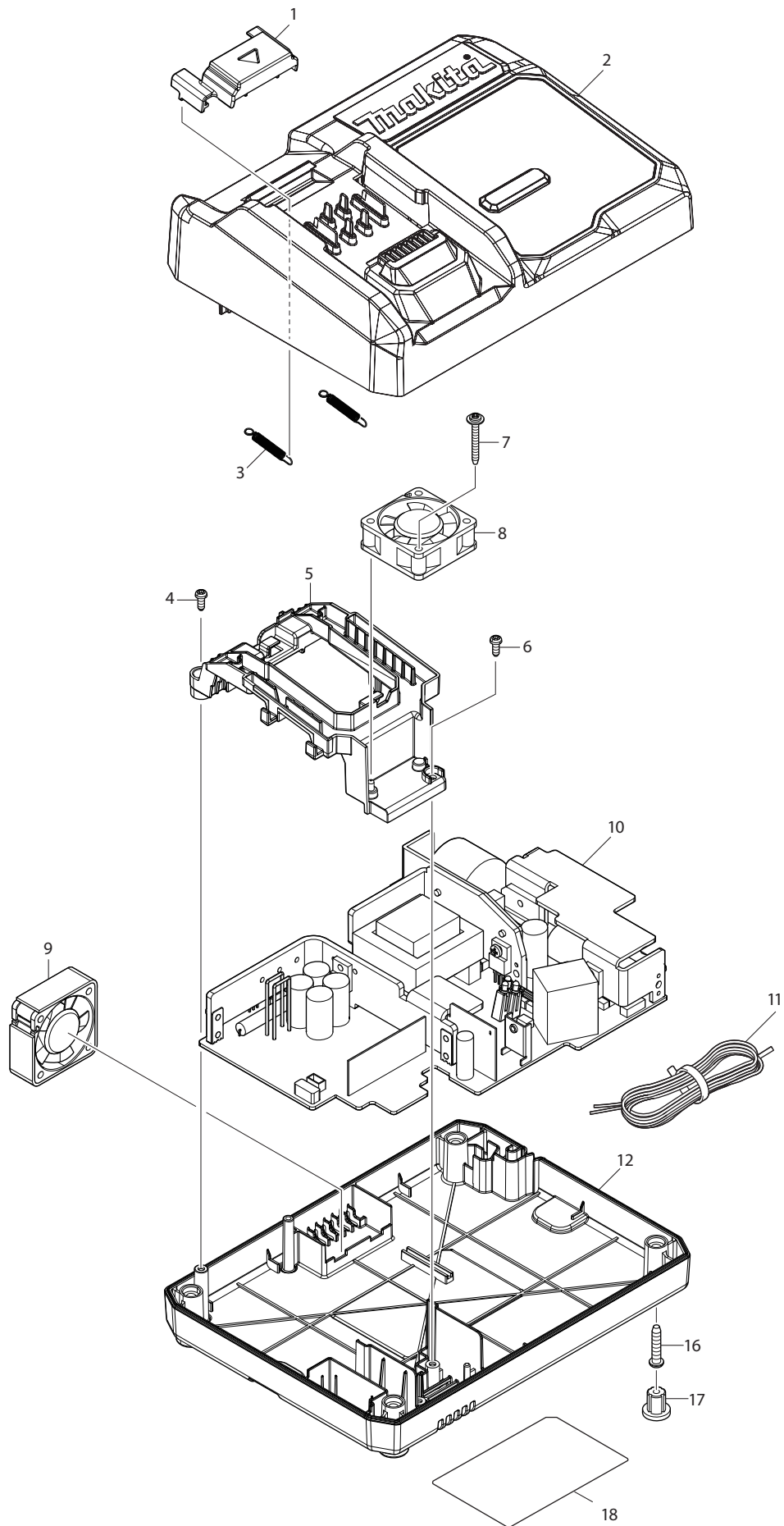

Model DC40RA Parts List

A = Standard Equipment

O = Circuit Diagram

Item#	Part#	Description	Q'ty	Unit
001	459475-4	TERMINAL COVER	1	PC.
002	140N46-9	CHARGER CASE COMPLETE	1	PC.
	C10 459476-2	LENS	1	PC.
	C20 819V01-7	CHARGING CONDITION LABEL	1	PC.
003	232565-6	TENSION SPRING 4	2	PC.
004	265B02-7	TAPPING SCREW 3X8	1	PC.
005	459474-6	TERMINAL BASE	1	PC.
006	265B02-7	TAPPING SCREW 3X8	1	PC.
007	265A61-5	TAPPING SCREW FLANGE 3X25	1	PC.
008	632P24-0	FAN 40	1	PC.
009	632P25-8	FAN 40	1	PC.
010	620B41-8	CHARGING CIRCUIT	1	PC.
010	C11 647075-4	VARISTOR	1	PC.
	C20 652089-0	FUSE	1	PC.
011	667982-5	VINYL CORD #18-2-2.0	1	PC.
012	459846-5	CHARGER CASE COVER	1	PC.
016	265B01-9	TAPPING SCREW PT 4X20	4	PC.
017	286255-3	CAP 13	4	PC.
018	857F48-7	DC40RA NAME PLATE	1	PC.
E01	819V02-5	CAUTION LABEL	1	PC.