

Item No.	Part No.	No. Used	Description	Item No.	Part No.	No. Used	Description
1	911146-6	4	P.H. Screw M4X25	42	315397-7	1	Bearing Box
4	221354-4	1	Spiral Bevel Gear 13	43	942101-7	1	Spring Washer 5
5	213407-3	1	O Ring 26	44	251259-4	1	(+) P.H. Screw M5X16
6	211063-3	1	Ball Bearing 6000LB	45	321336-7	1	5/8" Spindle
7	254002-0	1	Woodruff Key 3	46	253055-6	1	Flat Washer 12
8	962105-3	1	Retaining Ring R-26	47	211108-7	1	Ball Bearing 6201LB
9	241517-6	1	Fan (Old 241319-0)	48	962151-6	1	Retaining Ring R-32
10	615151-2	1	Armature Assy (Includes Items 9, 11 & 39)	49	221355-2	1	Spiral Bevel Gear 40
11	211033-2	1	Ball Bearing 608LB	50	961052-5	1	Retaining Ring S-12
12	410021-8	1	Baffle Plate	51	156902-9	1	Gear Housing Com. (With Items 52 - 55)
13	625136-0	1	Field Assy (Includes Items 22 & 30)	52	212005-0	1	Needle Bearing 810
14	681001-3	2	Insulation Washer	53	231252-4	1	Compression Spring 6
15	931102-0	4	Hex Nut M4	54	256616-1	1	Pin 5
16	911200-6	2	(+) P.H. Screw M4X70 (With Washer)	55	343312-1	1	Cup
17	263002-9	1	Rubber Pin 4	56	261039-0	1	Urethane Washer 14 (Makes it Easier to remove Wire Brush)
18	156901-1	1	Motor Housing (With Item 38)	<b>Accessories</b>			
19	191945-4	2	Carbon Brush CB-124 (2pcs/Set)	A01	164554-2	1	Wheel Cover Assy (With Items 43 & 44)
	191903-0	2	Auto Cut-Off Carbon Brush CB-112	A02	*	1	Inner Flange (For Depressed Center Wheel)
20	643600-9	2	Brush Holder Cap 6-10	A03	*	1	Lock Nut 5/8" (For Depressed Center Wheel, Cut-Off Wheel & Diamond Cutter)
21	953106-2	4	Rivet 0-5	A04	743015-1	1	5" Rubber Pad (For Abr. Disc.)
22	654019-7	2	Garter Spring	A05	224517-1	1	Lock Nut 5/8"-48 (For Abr. Disc)
23	411938-8	1	Rear Cover	A06	224054-5	1	Inner Flange 40 - Bulk (For Cut-Off Wheel & Diamond Cutter)
24	911293-3	2	P.H. Screw M5X70		<b>193553-7</b>	1	Inner Flange 40 - Packaged(For Cut-Off Wheel & Diamond Cutter)
25	682502-4	1	Cord Guard 8-85	A07	152492-0	1	Side Handle 36
26	664013-1	1	Cord With Plug 2P-18-2.5	A08	782412-6	1	Lock Nut Wrench
27	911121-2	2	P.H. Screw M4X14	A09	-----	1	5" Depressed Center Wheel (See Catalogue for Details)
28	687002-9	1	Strain Relief	A10	-----	1	5" Abrasive Disc (See Catalogue For Details)
29	411939-6	1	Switch Holder	A11	743205-6	1	3-1/4" Wire Cup Brush
30	654501-6	2	Solderless Connector P-1.25	A12	792155-2	1	5" Cut-Off Wheel (Grit C36)(5 pkg.)
31	911123-8	2	P.H. Screw M4X14		792156-0	1	5" Cut-Off Wheel (Grit A36)(5 pkg.)
32	231223-1	1	Compression Spring 6	A13	-----	1	Diamond Cutter
33	651466-3	1	Switch AC/DC				
34	257903-1	1	Stop Ring E-2.3				
35	410022-6	1	Switch Rod				
36	254002-0	1	Woodruff Key 3				
37	411741-7	1	Switch Lever (Black)				
38	643603-3	2	Brush Holder 6-10(Type 1)				
	643609-1	2	Brush Holder (Type 2)				
39	681615-8	1	Insulation Washer (Added)				
40	<b>682056-1</b>	1	Fibre Sleeve (Add.)				
41	911126-2	4	P.H. Screw M4X16				

\* SEE SERVICE CHANGES

**SERVICE CHANGES**

**1. Change on Inner Flange and Lock Nut .**

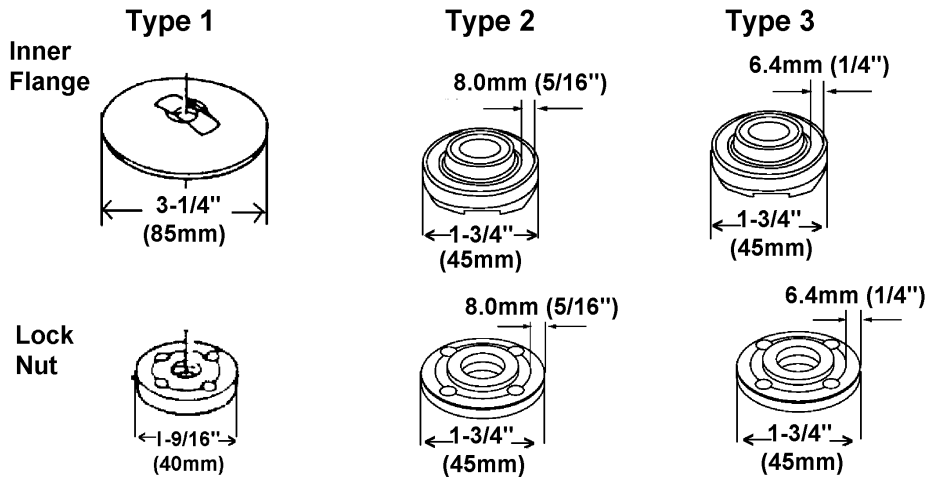

Item No.	Description	Type 1	Type 2	Type 3
A02	Inner Flange	224361-6 Inner Flange 85	224368-2 Inner Flange 45 (No Longer Available)	<b>224378-9</b> Inner Flange 45
A03	Lock Nut	224509-0 Lock Nut 5/8" - 40	224566-8 Lock Nut 5/8" - 45	<b>224568-4</b> Lock Nut 5/8" - 45

Above parts are completely interchangeable as a set.

**When replacing Inner Flange or Lock Nut make sure to use the same Type of Lock Nut or Inner Flange.**