

MODEL G5A - 30P WITH START - STOP CONTROL

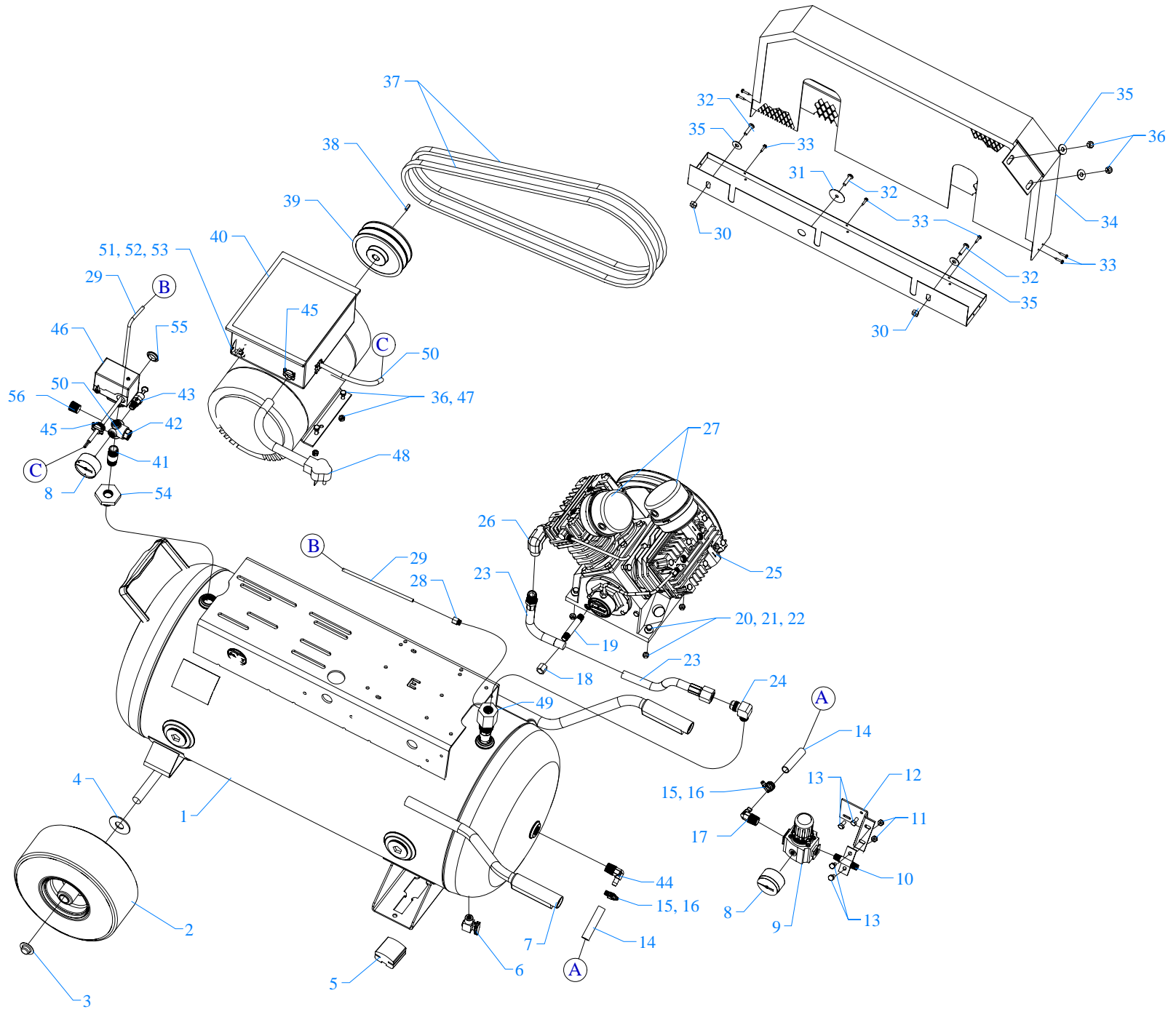

Parts List for Model G5A-30P-SSC

NOTE: The quantity number indicates the total number of pieces required for a complete unit repair.
When ordering parts give compressor model, serial number and part number. Order assemblies when possible.

<u>REF. NO.</u>	<u>PART NO.</u>	<u>DESCRIPTION</u>	<u>QTY.</u>
1	411-1192	TANK,PORTBL,30G,UNB,F&K&GE	1
2	JP2643-F	WHEEL,PNEUMATIC,10"ODX3/4"ID,BALLBRNG	2
3	120-1257	NUT,PAL,ST,PL,3/4"	2
4	JP2036-03	WASHER,STEEL,3/4ID,SAE	2
5	104-1249	PAD,RUBBER,40D,11GA,1-1/4X1-7/8X2-1/2,WP	2
6	141-1077	VALVE,BALL,LEVER,1/4 TURN,1/4"M X 1/4"F	1
7	104-1072	GRIP,HANDLE,RUBBER,YELLOW,7/8",STERILE	2
8	142-1000	GAUGE,PSI,200#,BK MT,JENNY,2",1/4NPT,PG2	2
9	160-1001	REGULATOR,PRESSURE,AIR,3/8"NPT	1
9A	360-1109	REGULATOR,PRESSURE,AIR,W/PG14,3/8"N,R38 INCLUDES 8,9,1/4"PLUG	1
10	150-1083	BRACKET,REGULATOR,STEEL,PLATED,3/8",BR	1
10A	320-1029	BRACKET,REGULATOR,W/HARDWARE,ASSY,BR INCLUDES 10,11,13	1
11	120-1116	NUT,LOCK,FLANGE,HEX,SERR,ST,PLTD,1/4-20	2
12	109-1153	BRACKET,REGULATOR,17P	1
13	120-1243	SCREW,FLANGE,HEX,SERR,ST,PL,1/4-20X 1/2	4
14	104-1022	HOSE,AIR,200 PSI,3/8"IDX30"LONG	1
15	120-1173	CLAMP,HOSE,GEAR,WORM,SS,5/16" TO 7/8"	2
16	104-1075	CAP,COVER,PLASTIC,RED,0.40 X 1/4"X 3/8"	2
17	121-1145	BARB,HOSE,ELBOW,MALE,BRASS,3/8HSX3/8NPTM	1
18	122-1127	CAP,HEX,MI,PLATED,3/8"NPT	1
19	122-1038	NIPPLE,STEEL,SCH 40,3/8" X 4" L	1
20	120-1009	SCREW,CAP,HEXHD,GR5,ST,PLTD,1/4-20X1-1/4	4

Parts List for Model G5A-30P-SSC

NOTE: The quantity number indicates the total number of pieces required for a complete unit repair.
When ordering parts give compressor model, serial number and part number. Order assemblies when possible.

<u>REF. NO.</u>	<u>PART NO.</u>	<u>DESCRIPTION</u>	<u>QTY.</u>
21	120-1071	WASHER,FLAT,STEEL,PLATED,USS,1/4"	4
22	120-1116	NUT,LOCK,FLANGE,HEX,SERR,ST,PLTD,1/4-20	4
23	360-1173	AFTERCOOLER,HOSE,SS,TEFLON,5/8"ODX24-1/2	1
24	121-1015	ELBOW,MALE,BRASS,5/8-45SAEX1/2"NPTM	1
25	421-1824	PUMP,CMPSR,PISTON,REPLCMT,BLUE,GU	1
26	122-1174	ELBOW,STREET,STEEL,PLTD,90 DEG,1/2"NPT	1
27	320-1121	FILTER,AIR,2PC,W/SILENCER&FILTER,G154	2
28	121-1025	CONNECTOR,MALE,COMPRESSION,BR,1/4TBX1/8"	1
29	610-1090	TUBE,CONTROL,COPPER,W/SLEEVE,1/4"X39"LG	1
30	120-1116	NUT,LOCK,FLANGE,HEX,SERR,ST,PLTD,1/4-20	2
31	120-1072	WASHER,FENDER,ST,PLATED,1/4"X1-1/2"OD	1
32	120-1267	SCREW,PAN HD,PHIL,STEEL,PLTD,1/4-20 X 1"	3
33	120-1177	SCREW,SELF DRILL,HEX,ST,PL,12 X 3/4	7
34	320-1009	BELTGUARD,ELECTRIC,G,ASSY,BLUE,BGL	1
35	120-1075	WASHER,FLAT,STEEL,PLATED,5/16"	4
36	120-1119	NUT,LOCK,FLANGE,HEX,SERR,ST,PLTD,5/16-18	6
37	154-4L540	BELT,VEE,A52,4L-540	2
38	120-1109	KEY,STEEL,BLACK,5/16X5/16X 1-1/2" LENGTH	1
39	154-1055	PULLEY,CI,DG,6.0PDA,1-1/8ID,2AK64X1-1/8	1
40	130-1089	MOTOR,5HP,230/60/1,1735RPM,ODP, TOP BOX	1
41	122-1145	NIPPLE,STEEL,SCH 80,PLTD,1/2" X 1-1/2" L	1
42	220-1121	BLOCK,MANIFOLD,ZINC,5 HOLE,TAPPED,MC-5	1
43	141-1004	VALVE,SAFETY,ASME,1/4",165 PSI,54 SCFM	1

Parts List for Model G5A-30P-SSC

NOTE: The quantity number indicates the total number of pieces required for a complete unit repair.
When ordering parts give compressor model, serial number and part number. Order assemblies when possible.

<u>REF. NO.</u>	<u>PART NO.</u>	<u>DESCRIPTION</u>	<u>QTY.</u>
44	121-1143	BARB,HOSE,ELBOW,MALE,BRASS,3/8HSX1/2NPTM	1
45	123-1029	CONNECTOR,ROMEX,CLAMP,STRAIGHT,3/8"	3
46	140-1074-01	SWITCH,PSI,2HP,100-125#,UNLDR&LVR,PBVL	1
47	120-1018	SCREW,FLANGE,HEX,SERR,ST,PLD,5/16-18X3/4	4
48	123-1128	CORD,DROP,SOWA,6-30PLUG,30A,10/3,7 FT	1
49	141-1036	VALVE,CHECK,INSERT,3/4"M X1/2"F,W/1/8"PT	1
50	123-1003	WIRE,ASSY,BX,14/2,WITH GROUND	2 FT
51	140-1117	GUARD,SWITCH,TOGGLE,STEEL,PLATED,15/32"	1
52	120-1174	RIVET,POP,BLIND,CLSD END,1/8",.063-.125	2
53	140-1112	SWITCH,TOGGLE,SP,ST,10A,250V,HBL11SP	1
54	122-1071	BUSHING,REDUCER,HEX,ST,PLTD,3/4" X 1/2"N	1
55	JD3856-02	PLUG,HOLE,PLASTIC,BLACK,1/2"	1
56	122-1047	PLUG,SOCKET,HEX,ST,PLTD,1/2" NPT	1
NOT SHOWN	610-1225	KIT,ELEMENT,FILTER,G54E,PKG OF 4,G54EP	1
NOT SHOWN	105-1209	OIL,PUMP,SYNTHETIC,BLUE,1 QUART,ESQ	1
NOT SHOWN	140-1125	CONTACTOR,DP,OP,2P,40A,230VAC	1

**MODEL G, GU, GC & GCU Four Cylinder - SingleStage
2-1/2" Bore X 2-3/8" Stroke**

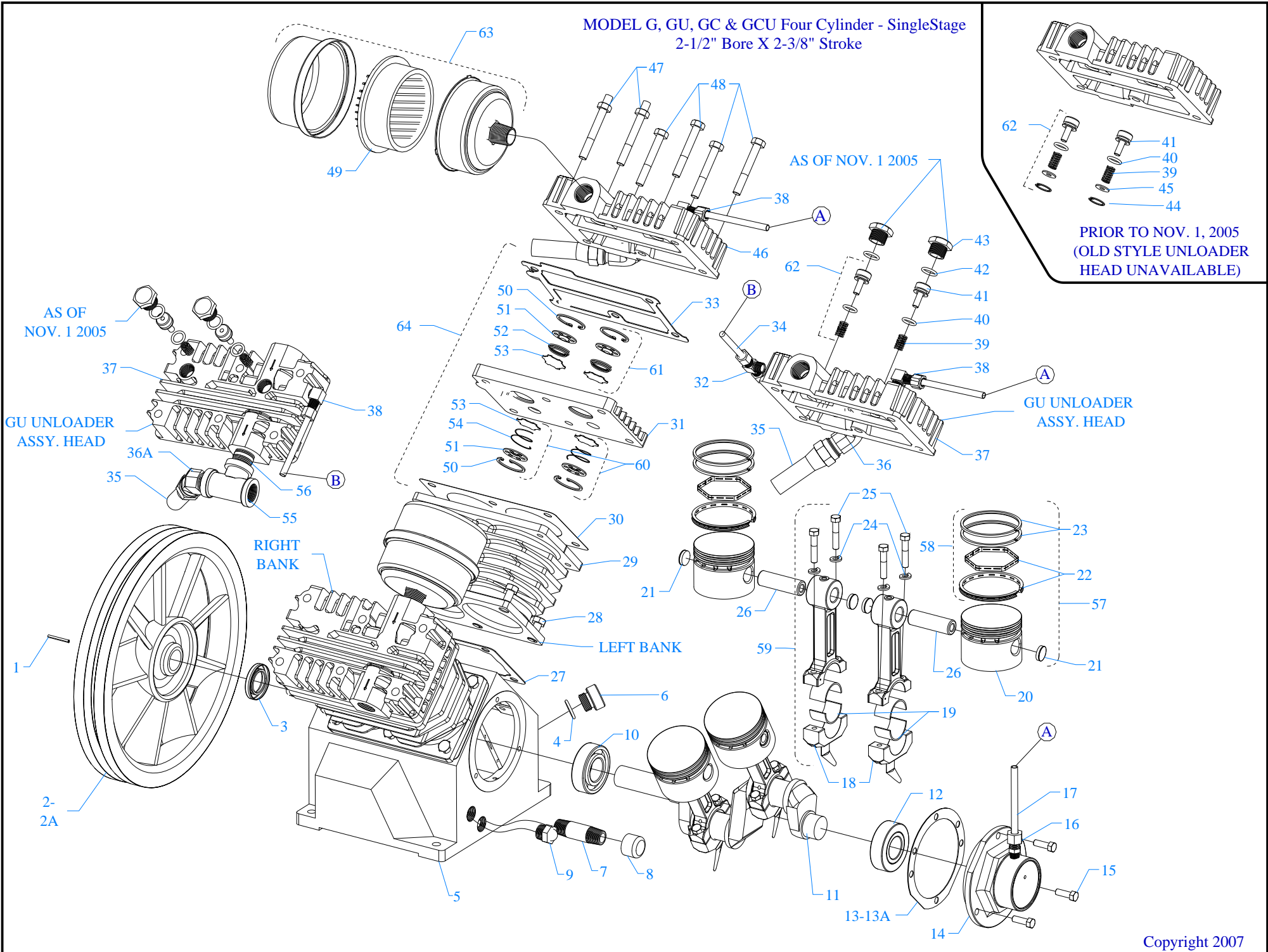

**PRIOR TO NOV. 1, 2005
(OLD STYLE UNLOADER
HEAD UNAVAILABLE)**

Parts List for Model G, MG, GU, MGU, GC, & GCU Assembly

NOTE: The quantity number indicates the total number of pieces required for a complete unit repair.

When ordering parts give compressor model, serial number and part number. Order assemblies when possible.

<u>REF. NO.</u>	<u>PART NO.</u>	<u>DESCRIPTION</u>	<u>QTY.</u>
1	120-1163	PIN,ROLLED,COILED,STL,BLK,1/4ODX1L,K25	1
2	220-1095	FLYWHEEL,G PUMP,CI,10-3/8,2 GROOVE,L23A	1
2A	220-1090	FLYWHEEL,GT PUMP,CI,13-1/4,2 GROOVE,G23	1
3	150-1036	SEAL,OIL,LIP,SINGLE,0.875 DIA,K11E	1
4	104-1016	RING,O,BUNA-N,5/8"IDX13/16"ODX3/32"THK	1
5	220-1034	CRANKCASE,Y PUMP,CI,MACHINED,Y1A	1
6	610-1029	PLUG,CRANKCASE,FILL,OIL,W/O-RING,K14	1
7	122-1037	NIPPLE,STEEL,SCH 40,3/8" X 2" L	1
8	122-1084	CAP,FEMALE,MI,3/8"NPT	1
9	160-1052	GAUGE,SIGHT,LEVEL,OIL,1/2"NPT	1
10	150-1000	BEARING,BALL,K9	1
11	220-1079	CRANKSHAFT,G PUMP,CI,MACHINED,D20	1
12	150-1008	BEARING,BALL,L9	1
13	104-1000-01	GASKET,CAP,BEARING,F&K&G PUMP,1/32THK,L3	1
13A	104-1000-02	GASKET,CAP,BEARING,F&K&G PUMP,1/64THK,L4	1
14	220-1076	CAP,BEARING,D PUMP,CI,MACHINED,D2	1
15	120-1004	SCREW,CAP,HEXHD,GR5,ST,BLK,1/4-20X3/4	3
16	121-1025	CONNECTOR,MALE,COMPRESSION,BR,1/4TBX1/8"	1
17	610-1137	TUBE,BREATHER,CU,BENT,MGU&GCU>U,L18	1
18	310-1043	ROD,CONNECTING,W/BEARNG INSERT,L21L&L21K	4
19	150-1011	BEARING,ROD,CONNECTING,PUMP,F,K,G	8
20	220-1005	PISTON,PUMP,ALUMINUM,MACHINED,K32	4
21	104-1103	BUMPER,WRIST PIN,PLASTIC,K36A	8

Parts List for Model G, MG, GU, MGU, GC, & GCU Assembly

NOTE: The quantity number indicates the total number of pieces required for a complete unit repair.

When ordering parts give compressor model, serial number and part number. Order assemblies when possible.

<u>REF. NO.</u>	<u>PART NO.</u>	<u>DESCRIPTION</u>	<u>QTY.</u>
22	610-1065	KIT,RING,OIL,W/EXPANDER,ASSY,K34	4
23	150-1003	RING,COMPRESSION,PISTON,STEEL,EBA 22,K33	8
24	120-1068	WASHER,LOCK,SPLIT,ST,BLK,HIGH CLLR,1/4"	8
25	120-1010	SCREW,CAP,HEXHD,GR5,ST,BLK,1/4-20X1-1/4	8
26	150-1005	PIN,PISTON,STEEL,HARDENED,K35	4
27	104-1006	GASKET,CYLINDER,K&G&W PUMP,1/32THK,K31	2
28	120-1017	SCREW,CAP,HEXHD,GR5,ST,BLK,5/16-18X3/4 (15FT-LB)	12
29	360-1150	CYLINDER,K PUMP,CI,PAINTED,BLUE,K30	2
30	104-1007	GASKET,PLATE,VALVE,K&G&W PUMP,1/32TK,L41	2
31	220-1013	PLATE,VALVE,L PUMP,CI,MACHINED,L40	2
32	121-1039	TEE,BRANCH,BRASS,1/4"TBX1/4"TBX1/8"NPTM	1
33	104-1008	GASKET,HEAD,K&G&W PUMP,1/32THK,L51	2
34	610-1121	TUBING,UNLOADER,HEAD-HEAD,MGU PUMP,LU88	1
35	610-1334	TUBE,MANIFOLD,COPPER,G,W/NUT,5/8,MS,MG59	1
36	121-1015	ELBOW,MALE,BRASS,5/8-45SAEX1/2"NPTM	1
36A	121-1021	ELBOW,BRASS,MALE,45DEG,5/8-45SAEX1/2"NPT	1
37	310-1008	HEAD,UNLOADING,K&G,W/1/2"PRT 7 HLE,LU180	2
38	121-1032	ELBOW,MALE,COMPRESSION,BR,1/4TBX1/8"NPTM	2
39	150-1020	SPRING,VALVE,UNLOADER,INTAKE, KU83	4
40	104-1020	RING,O,SILICON,7/16"IDX5/8"ODX3/32"THK	4
41	150-1028	PISTON,UNLOADER,VALVE,BRASS,KU81	4
42	104-1015	RING,O,BUNA-N,1/2"IDX11/16"ODX3/32"THK	4
43	122-1051	PLUG,HEX ,BRASS,11/16-16 UN-2B X .550	4

Parts List for Model G, MG, GU, MGU, GC, & GCU Assembly

NOTE: The quantity number indicates the total number of pieces required for a complete unit repair.

When ordering parts give compressor model, serial number and part number. Order assemblies when possible.

<u>REF. NO.</u>	<u>PART NO.</u>	<u>DESCRIPTION</u>	<u>QTY.</u>
44	120-1167	RETAINER,INTERNAL,ST,0.035X 0.665,KU85	4
45	150-1042	WASHER,BRASS,1/32X 0.605ODX1/4 ID,KU84	4
46	310-1004	HEAD,START/STOP,G PUMP,REPLACEMNT,L50	1
47	120-1252	BOLT,STUD,HEX,ST,5/16-18X2-1/4X5/8,K52-1	2
48	120-1028	SCREW,CAP,HEXHD,GR5,ST,BLK,5/16-18X2-1/4	10
49	150-1104	ELEMENT,FILTER,AIR,COMPRESSOR,JENNY,G54E	2
50	150-1041	RETAINER,VALVE,STEEL,PAS,0.062"THK,K43	8
51	109-1010	VALVE,BUMPER,STEEL,K44	8
52	150-1018	SPRING,CONE,SS,VALVE,DISCHARGE,K46	4
53	109-1011	VALVE,DISC,STAINLESS STEEL,K47	8
54	150-1017	SPRING,CONE,SS,VALVE,INTAKE,K45	4
55	122-1060	TEE,FEMALE,MI,PLTD,1/2"NPT	1
56	122-1042	NIPPLE,CLOSE,STEEL,SCH 80,1/2"NPTM	1
Assemblies			
57	610-1028	PISTON,W/RINGS&PIN,ASSY,K132 INCLUDES 20, 21(2), 22, 23, 26	4
58	610-1020	KIT,PUMP,RING,PISTON,F&K&G&W PUMP,K133 INCLUDES 22(2), 23(4)	2
59	610-1411	ROD,CONNECTING,W/BEARNG INSERT,L21L&L21K INCLUDES 18, 19(2), 24(2), 25	4
60	610-1031	VALVE,SUCTION,ASSY,K145 INCLUDES 50, 51, 53, 54	4
61	610-1032	VALVE,DISCHARGE,ASSY,K146 INCLUDES 50, 51, 52, 53	4
62	610-1042	VALVE,UNLOADER,HEAD,PUMP,ASSY, KU181 INCLUDES 39, 40, 41, 44, 45	4
63	320-1121	FILTER,W/DECALS,ASSY,G154S	2

Parts List for Model G, MG, GU, MGU, GC, & GCU Assembly

NOTE: The quantity number indicates the total number of pieces required for a complete unit repair.

When ordering parts give compressor model, serial number and part number. Order assemblies when possible.

<u>REF. NO.</u>	<u>PART NO.</u>	<u>DESCRIPTION</u>	<u>QTY.</u>
64	610-1045	PLATE,VALVE,W/VALVES,ASSY,L140 INCLUDES 30, 31, 33, 60(2), 61(2)	2
65	610-1044	KIT,GASKET,L PUMP,ASSY,L100 13, 13A, 27(2), 30(2), 33(2)	1
66	610-1298	KIT,BASIC,REPAIR,G PUMP,G101 INCLUDES 49(2), 58(2), 60(4), 61(4), 65	1
NOT SHOWN	610-1297	KIT,BASIC,REPAIR,GU&GCU PUMP,GU101 INCLUDES 49(2), 58(2), 60(4), 61(4), 62(4), 65	1
NOT SHOWN	105-1209	OIL,PUMP,SYNTHETIC,BLUE,1 QUART,ESQ	1
NOT SHOWN	610-1226	KIT,FILTER,ASSY,G154,PKG OF 4,G154P	1
NOT SHOWN	610-1186	KIT,ELEMENT,FILTER,L54E,PKG OF 4,L54EP	1
NOT SHOWN	150-1010	ELEMENT,FILTER,AIR,COMPRESSOR,JENNY,L54E	1