

# GROUP EV

ITEM	PART	QTY.	DESCRIPTION	ITEM	PART	QTY.	DESCRIPTION
1	0J4654	1	FRAME BASE ASSY XG8000E	47	0H1345	1	FUEL GAGE, 153 MM LONG ARM
2	0J4653	1	FRAME END ASSY XG8000E	48	0J8850	1	410CC ENGINE, 50HZ
3	0H2392C	1	ASSY.END PNL ALT. END	49	048031G	4	CLAMP HOSE BAND .41
4	0H2392A	1	ASSY,END PANEL XG8	50	0H2043	4	VIB MOUNT 35 X 12 X M8-1.25
5	0H2564	1	ASSY,FUEL TANK XG8 9GAL CARB	51	0E4190	1	CLAMP, 3/16" COATED CABLE
6	0H2394B	1	PANEL, SIDE	52	0F5579	1	SCREW HHC SHLDR M5-0.8X20 G8.8
7	0H2394A	1	PANEL,C/PNL SIDE	53	0H6059	8	SCREW FHSC M8-1.25 X 60 BZC
8	0J8185A	1	ASSY CTRL PNL 5600W XG 50HZ (MDL. 0062200)	54	0G3730	2	SCREW SHC M8-1.25 X 20 SEMS
	0J8185	1	ASSY CTRL PNL 6400W XG 50HZ (MDL. 0062210)	55	0H3033A	1	MUFFLER ASSY XG 5.6-7KW
9	0H6371	1	HEAT SHIELD, XG6.5-8	56	090239	1	GASKET, EXHAUST
10	0H4420	2	WHEEL,9.5" 1/2" AXLE,XG RALLYE	57	022129	5	WASHER LOCK M8-5/16
11	0H1129	2	AXLE, PIN, 1/2 IN, XG	58	0742600191	1	WIRE ASSEMBLY
12	087171	2	WASHER FLAT 1/2 SS	59	0B2236	1	NUT HEX LOCK M6-1 NY INS
13	0H3443	2	COTTER HAIRPIN 2.56 X .80	60	0H0025	1	ASSY 12VDC POWER JACK W/LUGS
14	022145	10	WASHER FLAT 5/16-M8 ZINC	61	0K0050	1	BRACKET MUFFLER 410
15	051731	4	SCREW HHC M8-1.25 X 50 C8.8	62	0G6392	1	BOOT, VINYL STARTER-SOLENOID
16	0G5445	4	SCREW HHTT M8-1.25 X 20	63	0742600189	1	WIRE ASSEMBLY
17	0L2176	2	SCREW HHSD PREMIUM 1/4-14X1 BZ	64	0H3535	4	NUT FLANGE M5-0.8 NYLOCK
18	0H3590	2	VIB MNT 38.4 X 30.5 X M8-1.25	65	052618	4	SCREW HHC M5-0.8 X 12 C8.8
19	067989	14	NUT HEX FL WHIZ M8-1.25	66	0742600193	1	WIRE ASSEMBLY
20	0H0720	1	BRACKET, BENT, FOOT, GX	67	0G9449	1	BATTERY 12V10AH SEALED
21	039253	4	SCREW HHC M8-1.25 X 20 C8.8	68	0H2764	1	BRACKET,BATTERY,HOLD DOWN
22	0G2018	1	SCREW HHSD 1/4-14 X 7/8	69	092079	2	SCREW HHTT M6-1.0 X 25 BP
23	055414	1	LUG SLDLSS #2-#8 X 17/64 CU	70	086729	1	CONTACTOR, STARTER SOLENOID
24	0742600186	1	GROUND WIRE BRG CAR-LUG 4KW	71	0H1411	4	RUBBER MOUNT, 10.8 ID X 9 TALL
25	0A1658	1	WASHER LOCK SPECIAL 1/4"	72	089338	2	NUT HEX LOCK #8-32 NY INS BRS
26	090388	4	SCREW HHTT M6-1.0 X 12 ZINC	73	027529	2	NUT HEX LOCK 1/4-20 NY INS
27	0G8465	2	GRIP NUBBED 1-1/4"X4-3/8"	74	0J8658	1	ALT 5600W XG 50HZ (MDL. 0062200)
28	0J1208B	1	ASSY HANDLE XG		0J8659	1	ALT 6400W XG 50HZ (MDL. 0062210)
29	0H5307	8	SPACER, SELF LOCATING	75	0G9832	1	BRACKET, MOUNTING ALT7KW
30	0F2659	1	SCREW HHTT M3-0.5 X 6 BP	76	046526	3	WASHER LOCK M10
31	0H9527	1	ASSY BUTTON HANDLE XG	77	022511	3	SCREW HHC 3/8-16 X 1-1/4 G5
32	0H2205	2	BEARING,HANDLE,XG	78	030209	1	SCREW HHC 5/16-24 X 1-1/4 G5
33	0H9525	2	BEARING EXTERNAL HANDLE XG	79	0H0919	1	ASSEMBLY, BRUSH VISION
34	0H9529B	1	BRACKET MOUNTING HANDLE	80	0H0228C	1	WIRE ASSY RED SOL TO SOL
35	0H6887	2	BOLT CARR 5/16-18 X 2" G2	81	0H3049	1	COVER ALTERNATOR INLET (5-7 KW)
36	0G8382	4	SCREW PPPH #8-16 X .66" BZC	82	049226	3	LOCK WASHER M5
37	0H2142	1	VALVE HOLDER,FUEL SHUTOFF	83	049815	3	SCREW HHC M5-0.8 X 16 G8.8
38	0G9549	1	SWITCH SPDT (ON)-OFF-ON 20A	84	051713	2	FLAT WASHER M5
39	0G9560A	1	CABLE CHOKE PORT NOM 382	85	0H4218	2	HARNESS ENGINE GH410 XG ES
40	0H3455E	1	FUEL HOSE, 160 MM LONG	86	0742600188	1	BATTERY CABLE
41	0H3419	1	VALVE,FUEL SHUTOFF	87	0742600192	1	BATTERY CABLE
42	0H2579B	1	AVR 5.5-7.5KW VISION ALT	88	0H5762	1	FUEL LINE FORMED VLV TO ENG XG
43	0H1326	1	FILTER, FUEL	89	045771	2	NUT HEX M8-1.25 G8 CLEAR ZINC
44	0H1325A	1	FUEL CAP,VENTED, CHROME CAP	90	0H2565	1	WELDMENT,TANK,FUEL,XG 9GAL
45	0H1357	2	SCREW PFHM M5-0.8 X 12	91	0G8486	1	CAP NUT 5/16-18 ZBC
46	0H1359	1	PLATE, FUEL GAGE	92	0H1610	4	INSERT, ANTI-CRUSH FOR TANKS

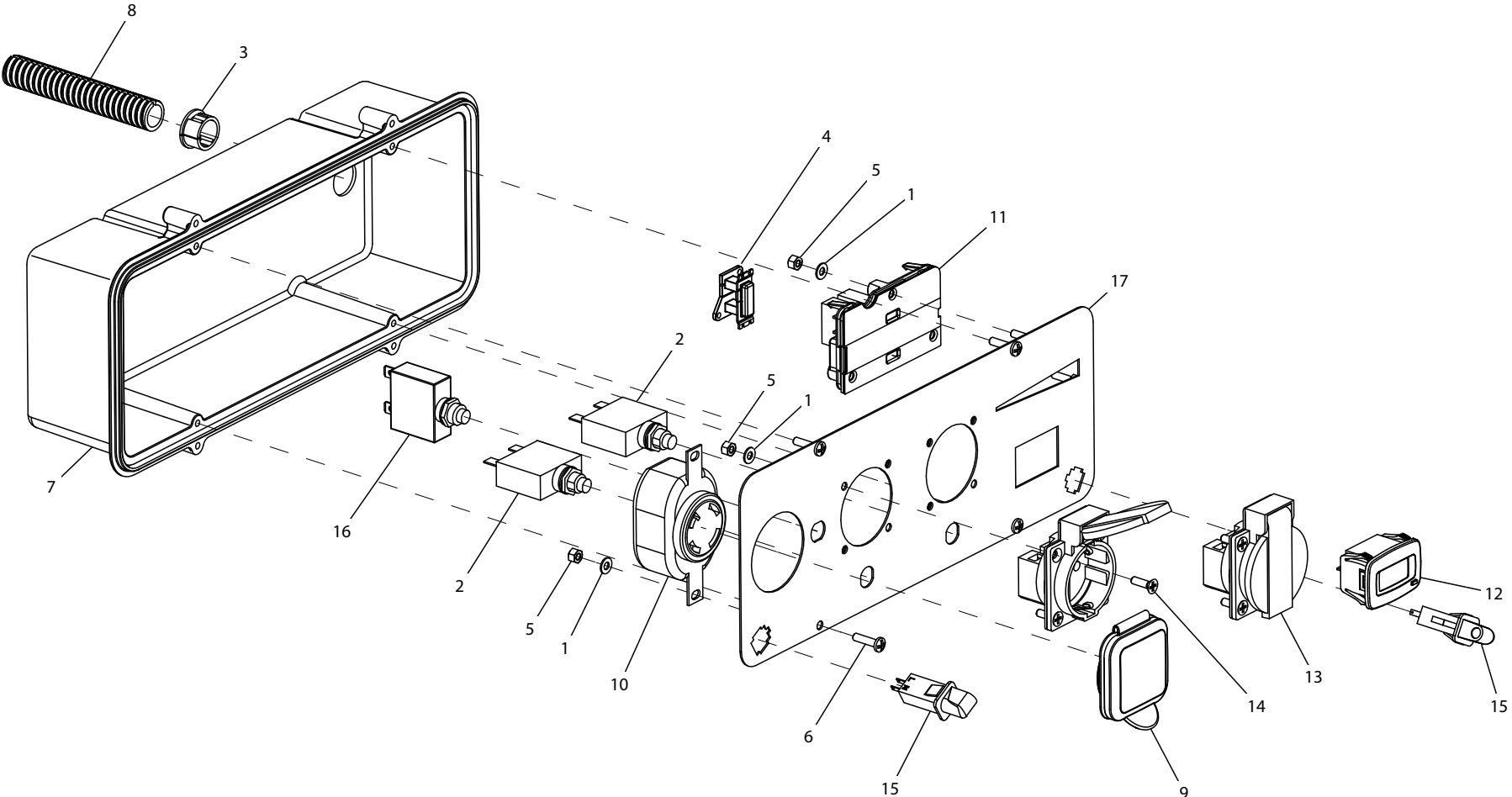

ITEM	PART	QTY.	DESCRIPTION
1	043180	13	WASHER FLAT M4
2	075207L	2	CB 0016A 1P UL/CSA
3	0A5489	1	SNAP BUSHING .75 OPEN
4	0D4804B	1	XFMR IDLE CURRENT
5	0E6480	13	NUT HEX LOCK M4-0.7 NY INS
6	0G8382	4	SCREW PPPH #8-16 X .66" BZC
7	0G9756	1	RECPTACLE PANEL STORM-GEN
8	077043B	0.8 FT	CONDUIT FLEX .50" ID
9	0G9391	1	COVER,30A 120/240V
10	0H2929	1	OUTLET 30A 120/250V SPCGR
11	0H3362B	1	TRULOAD POWERBAR ASSY 6.5KW
12	0H8214	1	HOUR METER W/ALERTS AC/DC
13	0J7877	2	OUTLET CEE 7/4 16A TYPE F
14	0J8080	8	SCREW PFHM M4-0.7 X 14
15	0J8222	2	SNAP FIT LED XG 230V
16	0H0265D	1	CB 25A 1P CUL/CSA (MODEL 0062200 ONLY)
	0H0265E	1	CB 30A 1P CUL/CSA (MODEL 0062210 ONLY)
17	0J8188A	1	WLDMNT CTRL PNL 5600W XG 50HZ (MODEL 0062200 ONLY)
	0J8188	1	WLDMNT CTRL PNL 6400W XG 50HZ (MODEL 0062210 ONLY)

FLYWHEEL OPTION  
ENGINE PRODUCTION LEVEL 10E

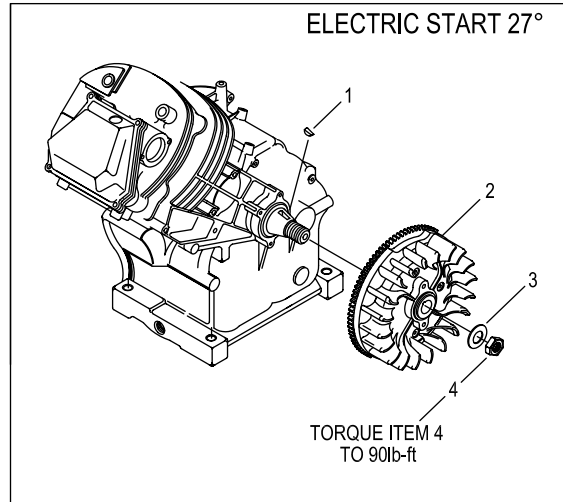

1	082774	1	KEY, WOODRUFF 4 x 19D
2	091222C	1	ASSY, FLYWHEEL W/RING GEAR 27 DEGREE
3	067198N	1	WASHER, BELV-20 X 2.2
4	067890	1	NUT, HEX – FLYWHEEL