

DISC SANDER

G-1810C

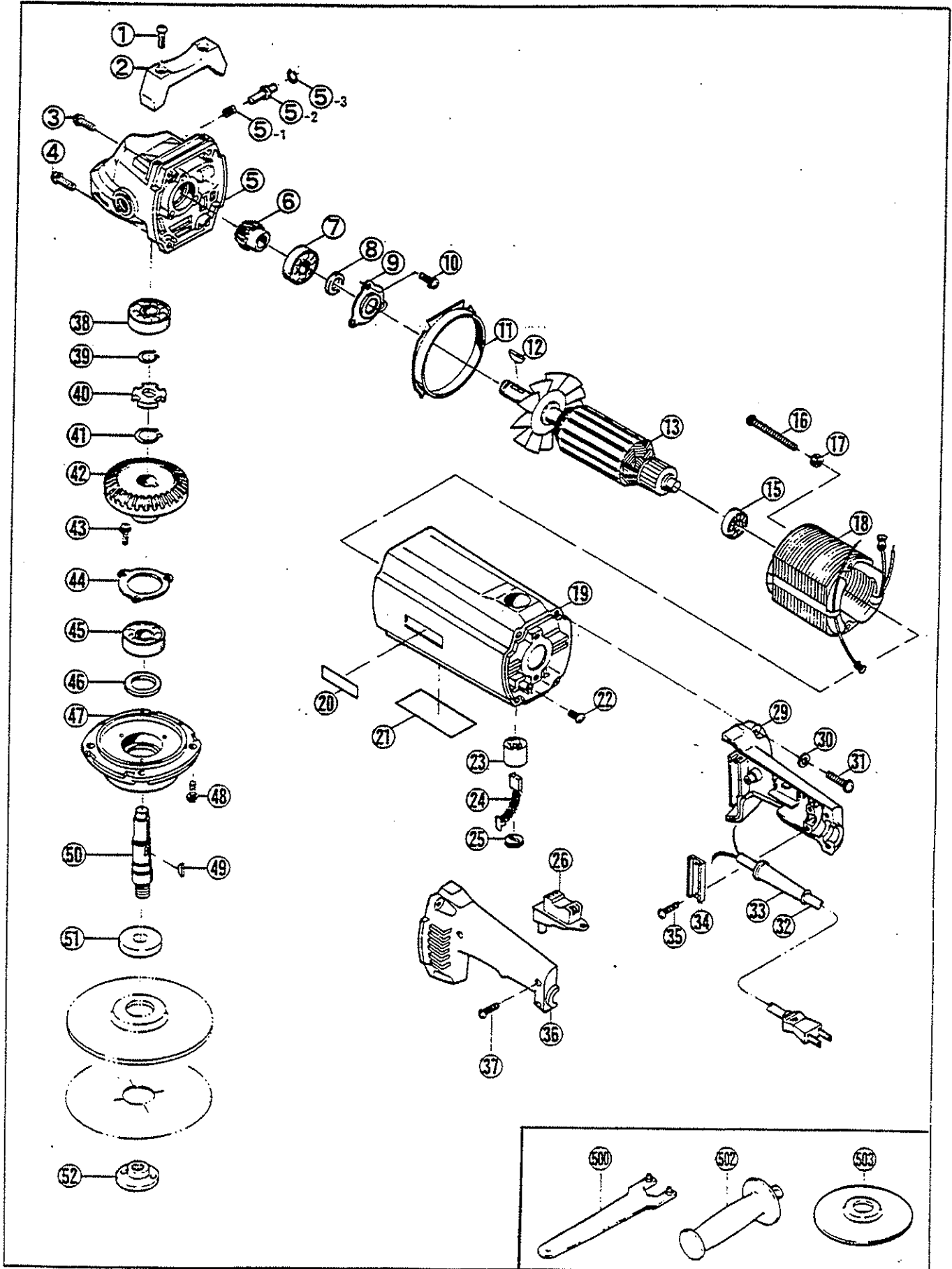

PARTS LIST FOR AFTER SALES SERVICE MODEL G1810C

P	PART NO.	DESCRIPTION	QTY	REF	PART NO.	DESCRIPTION	QTY
	9000615	PHILLIPS PAN SCREW M6X15	2	30	9560600	WASHER	4
2	6370068	TOOL REST	1	31	9020630	PHILLIPS PAN SCREW M6X30	4
3	9020540	PHILLIPS PAN SCREW M5X40	2	32	6520221	CORD ASS'Y AWG16X2X2	1
4	9020520	PHILLIPS PAN SCREW M5X20	2	33	6560047	CORD HOLDER	1
5	6080755	GEAR CASE	1	34	6560103	CORD CLAMP	1
5-1	6180090	COMPRESSION SPRING	1	35	9060414	TAPPING SCREW (B) M4X14	2
5-2	6120084	STOPPER PIN	1	36	6830534	HANDLE (B)	1
5-3	6100079	RETAINING RING R-13	1	37	9060425	TAPPING SCREW (B) M4X25	3
6	6200069	PINION GEAR	1	38	9846200	BALL BEARING #6200LLB	1
7	9856201	BALL BEARING #6201LLU	1	39	9511400	RETAINING RING S-14	1
8	6900225	FELT WASHER	1	40	6220027	STOPPER	1
9	6150629	CLAMP PLATE	1	41	9511700	RETAINING RING S-17	1
10	9020512	PHILLIPS PAN SCREW M5X12	3	42	6200060	FINAL GEAR	1
11	6490110	FAN CASING	1	43	9020512	PHILLIPS PAN SCREW M5X12	3
12	6100630	WOODRUFF KEY	1	44	6151127	CLAMP PLATE	1
13	6030637	ARMATURE	1	45	9896203	BALL BEARING #6204LLH	1
15	9856200	BALL BEARING #6200LLU	1	46	6390027	FELT	1
16	6130337	HEX HEAD SCREW M5X85	2	47	6820220	GEAR CASE COVER	1
17	6150007	LOCK WASHER	2	48	9020520	PHILLIPS PAN SCREW M5X20	4
18	6500591	FIELD COIL	1	49	6100630	WOODRUFF KEY	1
19	6800554	MOTOR HOUSING	1	50	6110059	SPINDLE	1
20	6920006	"RYOBI" MARK #11	2	51	6900223	COLLAR	2
21	6910945	NAME PLATE	1	52	6072873	CLAMP NUT	1
22	9000512	PHILLIPS PAN SCREW M5X12	2	—	6560026	TERMINAL	4
23	6570032	BRUSH HOLDER	2				
24	6540363	CARBON BRUSH SET	1				
25	6570033	BRUSH CAP	2	500	6240363	LOCK-NUT WRENCH 35	1
26	6550450	TRIGGER SWITCH	1	502	6830536	SIDE HANDLE	1
29	6830527	HANDLE (A)	1	503	6940234	7" SANDING PAD	1

STANDARD ACCESSORIES

SERVICE NOTES:

