

## ELECTRIC TOOL PARTS LIST

### ■ AIR COMPRESSOR Model EC 10SB

2002 • 12 • 20

(E3)

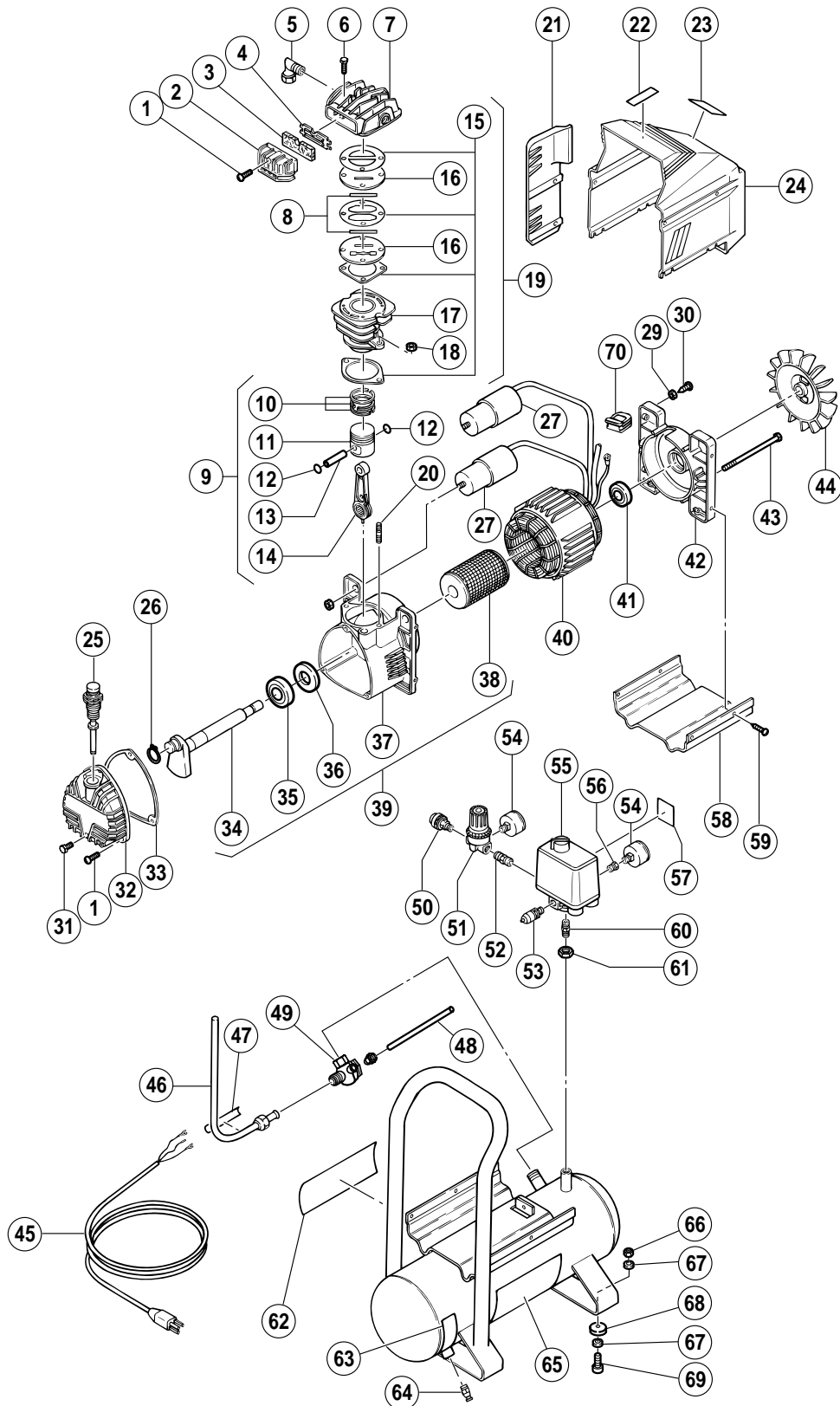

Model EC 10SB (S)  
Model EC 10SB (SL)

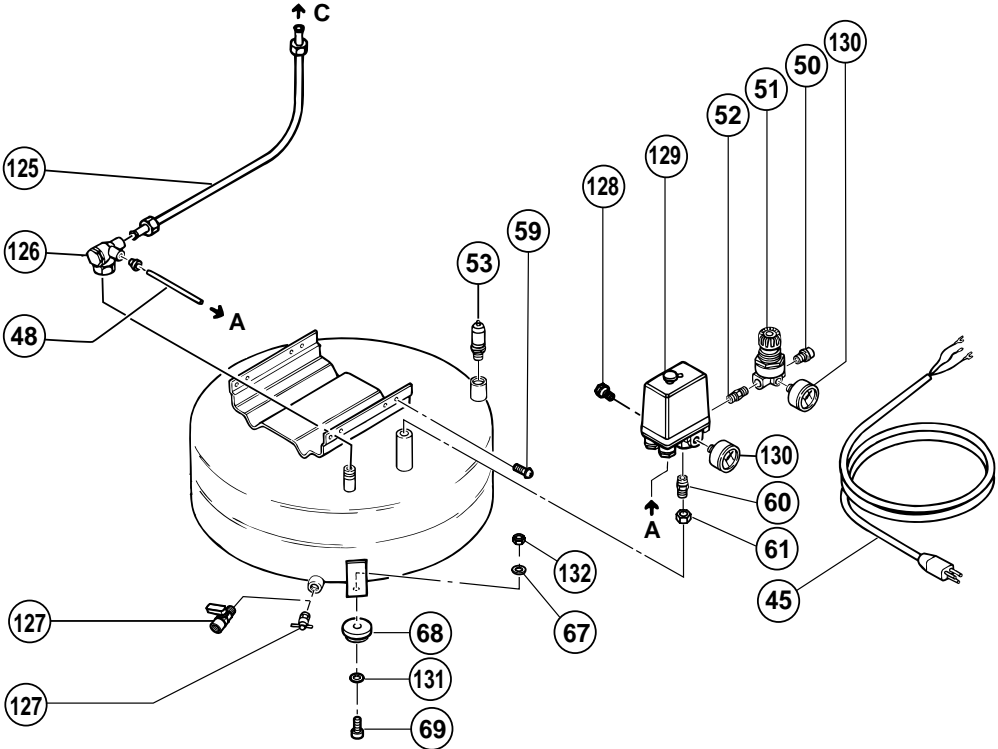
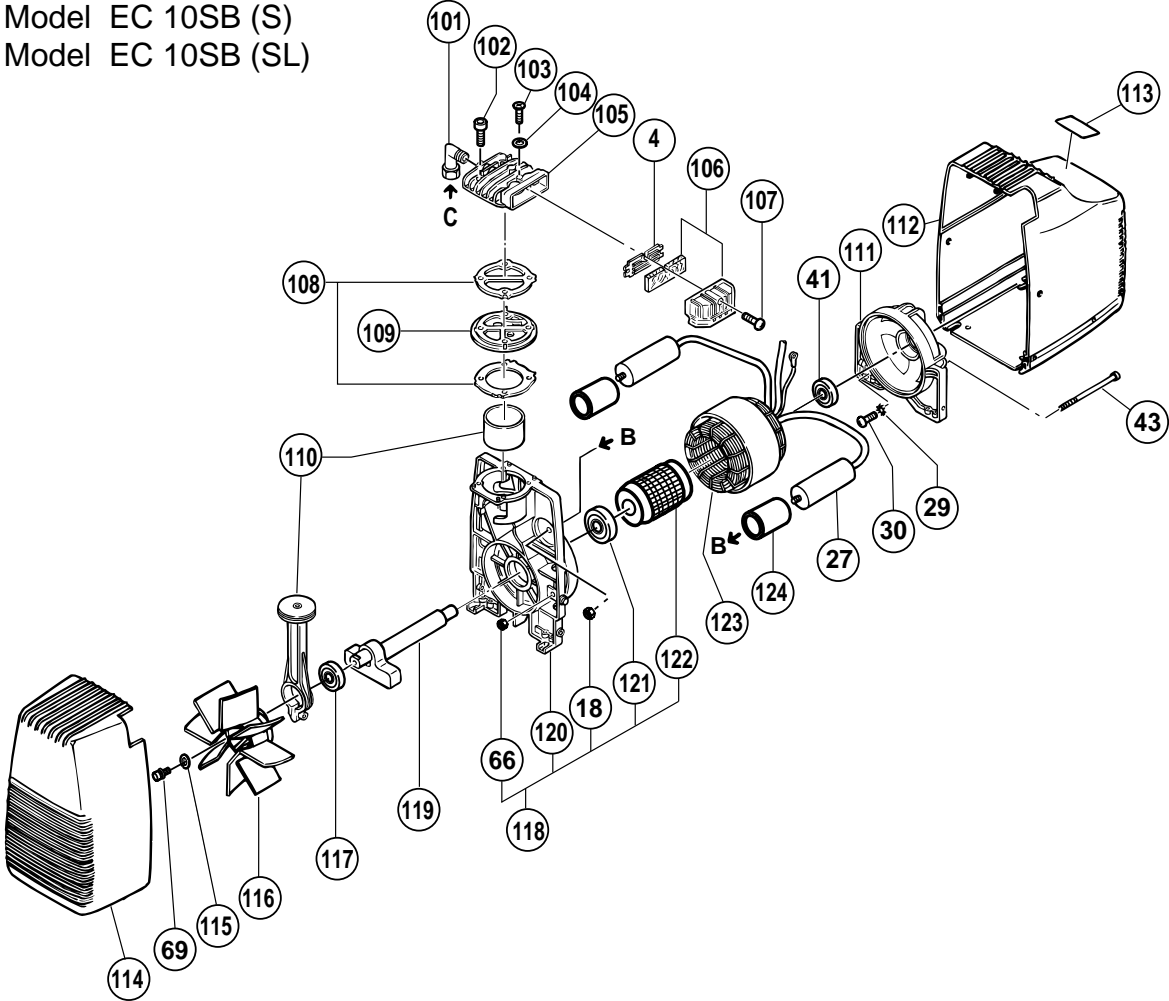

**PARTS**

EC 10SB

ITEM NO.	CODE NO.	DESCRIPTION	NO. USED	REMARKS
1	881-472	SCREW	4	
2	881-554	INTAKE FILTER	1	
3	881-553	FILTERING ELEMENT	1	
4	881-453	FILTER PLATE	1	
5	881-552	JOINT	1	
6	881-551	SCREW	4	
7	881-550	HEAD	1	
8	881-490	SET OF VALVE	1	
9	882-589	CONNECTING ROD AND PISTON SET	1	
10	881-460	PISTON RING	1	
11	881-461	PISTON	1	
12	881-463	RING	2	
13	881-462	PISTON PIN	1	
14	881-561	CONNECTING ROD	1	
15	881-457	SET OF GASKET	1	
16	881-458	VALVE PLATE	2	
17	881-459	CYLINDER	1	
18	881-489	NUT	2	
19	882-588	PLATES AND VALVES SET	1	
20	881-465	STUD BOLT	2	
21	881-569	PIPE PROTECTION	1	
22		WARNING LABEL (B)	1	
23		NAME PLATE	1	
24	882-586	HOUSING	1	
25	881-469	DIPSTICK	1	
26	881-468	SEEGER	1	
27	881-488	CAPACITOR	2	
29	881-485	WASHER	1	
30	881-484	SCREW	1	
31	881-471	SCREW	1	
32	881-470	CARTER COVER	1	
33	881-473	GASKET	1	
34	882-580	CRANK SHAFT	1	
35	881-466	BALL BEARING	1	
36	881-474	SMIM RING	1	
37	882-581	CARTER	1	
38	881-563	ROTOR	1	
39	882-590	CARTER SHAFT AND ROTOR SET	1	
40	881-564	MOTOR CASING	1	
41	881-478	BALL BEARING	1	
42	882-585	COVER	1	
43	881-480	TENSION ROD	1	
44	881-565	FAN	1	
45	881-503	INFEED CABLE	1	
46	882-592	INFEED TUBE	1	
47		WARNING LABEL (E)	1	
48	881-496	TUBE	1	
49	882-593	NON RETURN VALVE	1	
50	881-509	JOINT	1	
51	881-510	PRESSURE REDUCER	1	
52	881-511	JOINT	1	

**PARTS**

EC 10SB

ITEM NO.	CODE NO.	DESCRIPTION	NO. USED	REMARKS
53	881-493	SAFETY VALVE	1	
54	882-591	PRESSURE GAUGE	2	
55	881-575	PRESSURE SWITCH	1	
56	881-576	JOINT	1	
57		WARNING LABEL (C)	1	
58	882-584	BASE	1	
59	881-410	SCREW	4	
60	881-505	JOINT	1	
61	881-504	BLOCKING NUT	1	
62		WARNING LABEL (A)	1	
63		WARNING LABEL (D)	1	
64	882-594	DISCHARGE TAP	1	
65		HITACHI LABEL	1	
66	881-401	NUT	4	
67	881-419	WASHER	8	
68	881-577	RUBBER	4	
69	881-399	SCREW	4	
70	882-587	CHOCK	1	
101	881-455	JOINT	1	FOR MODEL EC10SB (S), (SL)
102	881-392	SCREW	4	FOR MODEL EC10SB (S), (SL)
103	881-415	SCREW	1	FOR MODEL EC10SB (S), (SL)
104	881-414	WASHER	1	FOR MODEL EC10SB (S), (SL)
105	881-456	HEAD	1	FOR MODEL EC10SB (S), (SL)
106	882-620	INTAKE FILTER	1	FOR MODEL EC10SB (S), (SL)
107	881-412	SCREW	1	FOR MODEL EC10SB (S), (SL)
108	881-393	SET OF GASKET	1	FOR MODEL EC10SB (S), (SL)
109	882-595	MONOPLATE	1	FOR MODEL EC10SB (S), (SL)
110	882-596	CONNECTING ROD CYLINDER KIT	1	FOR MODEL EC10SB (S), (SL)
111	881-409	COVER	1	FOR MODEL EC10SB (S), (SL)
112	882-602	MOTOR HOUSING	1	FOR MODEL EC10SB (S), (SL)
* 113		NAME PLATE	1	
114	881-398	COMPRESSOR HOUSING	1	FOR MODEL EC10SB (S), (SL)
115	881-573	WASHER	1	FOR MODEL EC10SB (S), (SL)
116	882-598	FAN	1	FOR MODEL EC10SB (S), (SL)
117	882-597	BALL BEARING	1	FOR MODEL EC10SB (S), (SL)
118	882-604	CARTER SHAFT AND ROTOR SET	1	FOR MODEL EC10SB (S), (SL)
119	882-599	CRANK SHAFT	1	FOR MODEL EC10SB (S), (SL)
120	881-402	CARTER	1	FOR MODEL EC10SB (S), (SL)
121	881-404	BALL BEARING	1	FOR MODEL EC10SB (S), (SL)
122	882-600	ROTOR	1	FOR MODEL EC10SB (S), (SL)
123	882-601	WOUND STATOR	1	FOR MODEL EC10SB (S), (SL)
124	881-638	CAPACITOR SHROUD	2	FOR MODEL EC10SB (S), (SL)
125	882-608	INFEED TUBE	1	FOR MODEL EC10SB (S), (SL)
126	882-607	NON RETURN VALVE	1	FOR MODEL EC10SB (S), (SL)
* 127	881-498	DISCHARGE TAP	1	FOR MODEL EC10SB (S)
* 127	882-610	DISCHARGE TAP	1	FOR MODEL EC10SB (SL)
128	881-513	PLUG	1	FOR MODEL EC10SB (S), (SL)
* 129	882-609	PRESSURE SWITCH	1	FOR MODEL EC10SB (S)
* 129	882-611	PRESSURE SWITCH	1	FOR MODEL EC10SB (SL)
130	882-606	PRESSURE GAUGE	2	FOR MODEL EC10SB (S), (SL)
131	881-573	WASHER	4	FOR MODEL EC10SB (S), (SL)



