

# Repair Parts

## Parts List For RIDGID Oscillating Edge Belt/Spindle Sander Model EB44240

RIDGID parts are available on-line at [www.ridgidparts.com](http://www.ridgidparts.com)

Figure 1

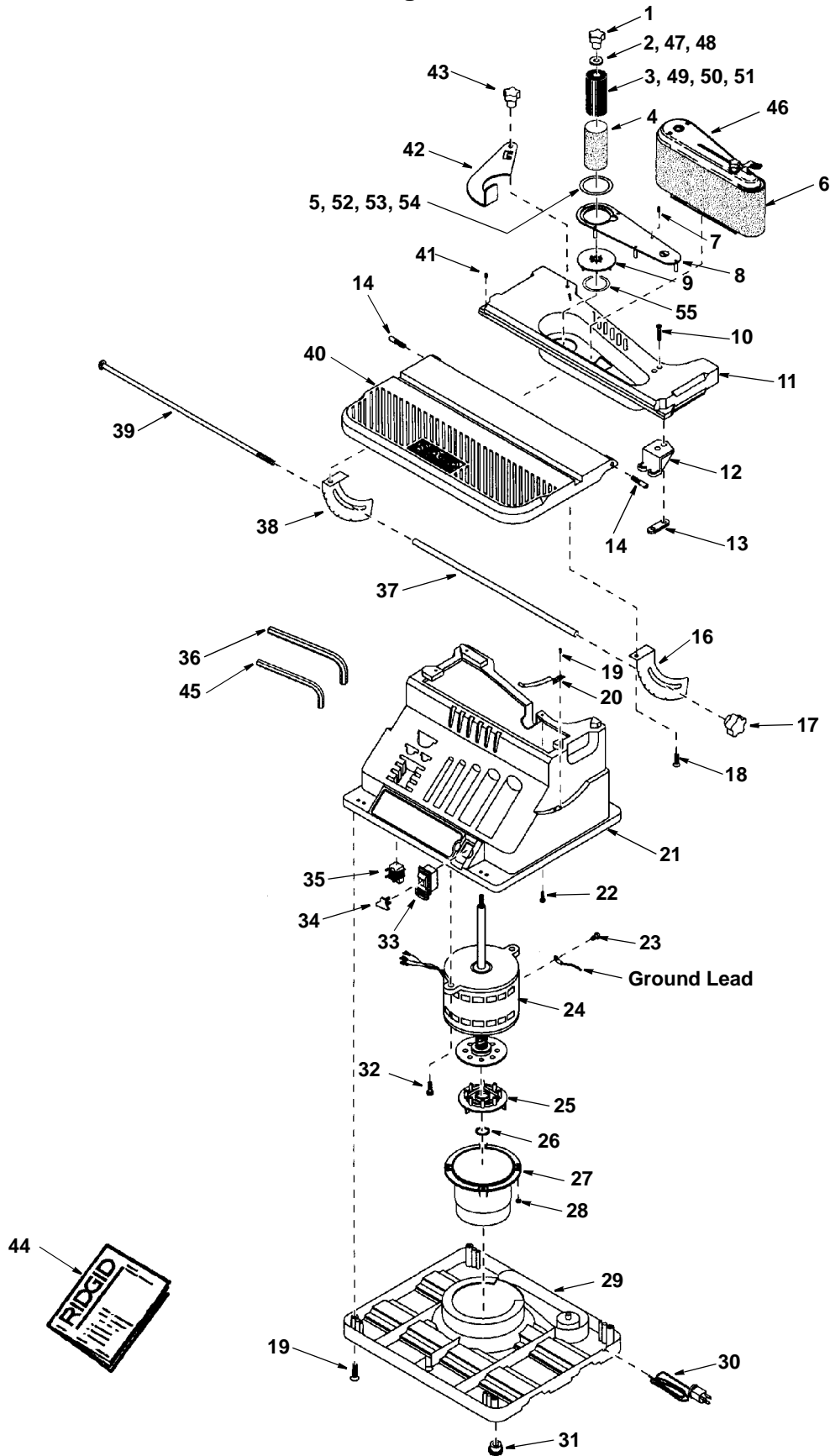

# Repair Parts

## Parts List For RIDGID Oscillating Edge Belt/Spindle Sander Model EB44240

RIDGID parts are available on-line at [www.ridgidparts.com](http://www.ridgidparts.com)

Figure 1

Always order by Part Number—Not by Key Number

Key No.	Part No.	Description	Key No.	Part No.	Description
1	826358	Knob Spindle	28	822356	Nut Hex Flange Lock 8-32
2	805553-2	Washer 21/64 x 5/8 x 1/32	29	826801	Enclosure
3	822304	Drum Sanding 3/4"	30	825854	Cord w/Plug
4	†	Drum Sandpaper	31	819012	Foot
5	825808	Plate Throat 2"	32	9416630	Screw Hex Hd Ty "T" 5/16-18 x 1
6	†	Belt Sanding 4" x 24"	33	826347	Switch Locking
7	810993-2	Screw Set Half Dog 10/32 x 1/2	34	AC1000	† Key Switch
8	825841	Adapter Throat Plate	35	817399-11	Relay
9	825544	Fan	36	37837	Wrench Hex "L" 5/32
10	805297-9	Screw Flat Hd 1/4-20 x 5/8	37	825549	Spacer Table Lock
11	825523	Table Rear	38	825537-1	Bracket Table Lock Left
12	825548	Plate Wear	39	825543	Bolt Table Lock
13	825844	Nut Special Twin 1/4-20	40	825524	Table Front
14	825842	Screw Shoulder 1/4-20	41	803309-2	Screw Soc Set Lock 10-32 x 3/8
15			42	825525	Plate Stop
16	825537	Bracket Table Lock	43	825539-1	Knob 1/4-20
17	825852	Knob 1/4-20 x 3/4	44	SP6001	Owners Manual
18	159572-138	Screw Wash/Hd Ty "T" 10-32 x 3/8	45	37836	Wrench Hex "L" 3/32
19	808380-7	Screw Pan Hd 10-14 x 1/2	46	—	Belt Sanding Assembly (See Fig. 2)
20	825840	Spring Detent	47	60358	* Washer 5/8 x 1-3/4 x 1/8
21	826803	Base	48	805553-24	Washer 21/64 x 7/8 x 3/64
22	159572-186	Screw Hex Hd Ty "T" 1/4-20 x 1	49	822304-1	Drum Sanding 1"
23	824604	Screw Hex Wash/Hd Ty "T" 8-32 x 3/8	50	822304-2	Drum Sanding 1-1/2"
24	826783	• Motor Asm	51	822304-3	Drum Sanding 2"
25	826469	Follower Cam	52	825808-1	Plate Throat 1-1/2"
26	805641-1	Ring Retaining 5133-31	53	825808-2	Plate Throat 1"
27	826470	Housing	54	825808-3	Plate Throat 1/2"
			55	805642	Ring, Retaining 5160-50

\* Standard Hardware Item - May be purchased locally

† These parts are available where you purchased your sander.

- Any attempt to repair this motor may create a hazard unless repair is done by a qualified service technician. Repair service is available at your nearest Authorized Service Center.

# Repair Parts

## Parts List For RIDGID Oscillating Edge Belt/ Spindle Sander Model EB44240

RIDGID parts are available on-line at [www.ridgidparts.com](http://www.ridgidparts.com)

Figure 2

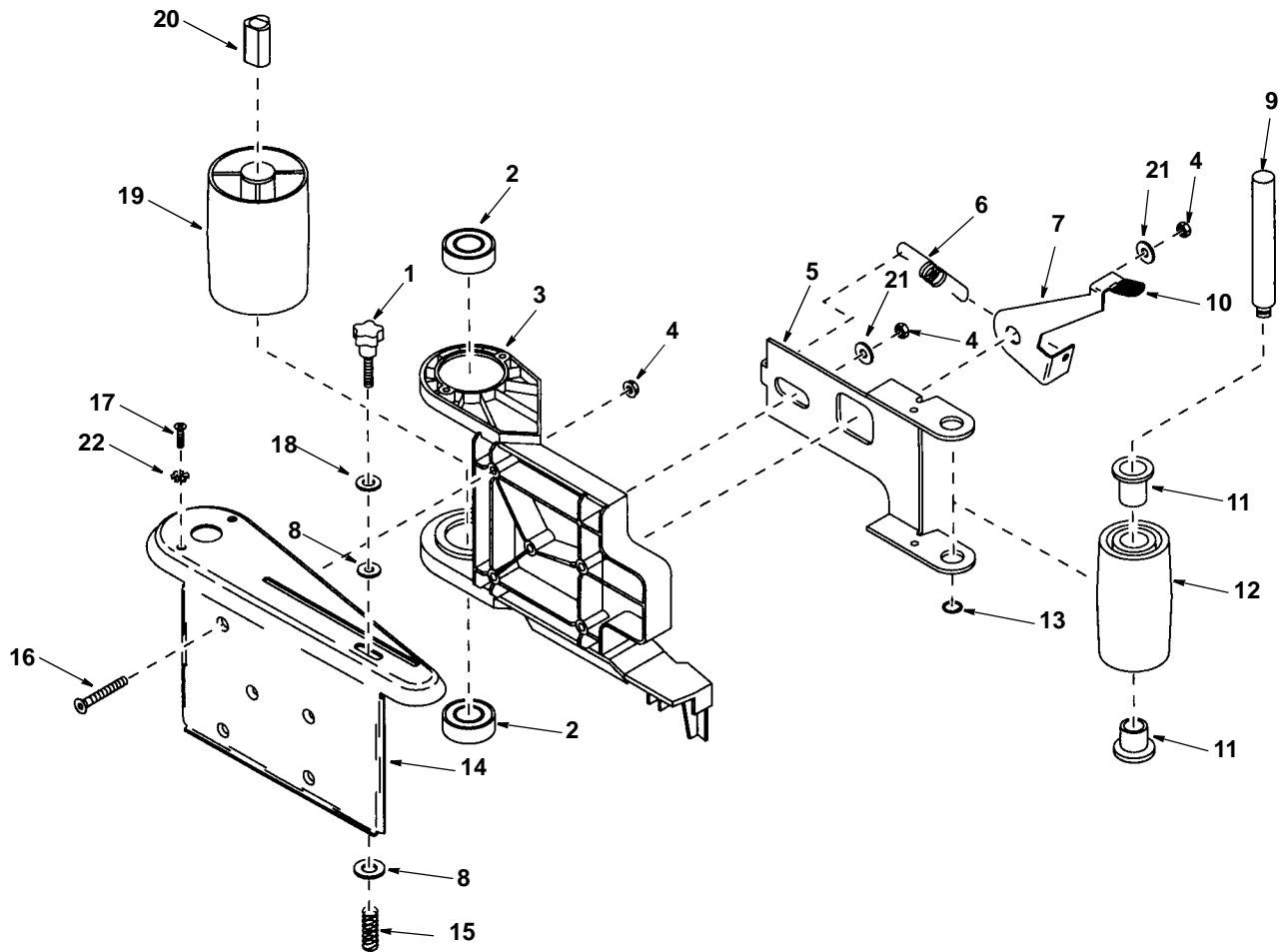

Always order by Part Number—Not by Key Number

Key No.	Part No.	Description
1	825539	Knob 10-32 x 1-1/4
2	825541	Bearing Ball
3	825526	Bed
4	37482	Nut Lock
5	825528	Guide
6	825531	Spring Extension
7	825529	Lever
8	805549-5	* Washer 13/64 x 1/2 x 3/64
9	825532	Shaft Idle
10	826163-2	Cap Grip
11	825838	Bushing

Key No.	Part No.	Description
12	825542	Drum Idle
13	805642	Ring Retaining 5160-50
14	826802	Platen
15	30521	Spring Swivel
16	821166-1	Screw Flat Hd Hex 10/32 x 1-1/2
17	808380-5	Screw Pan hd #8 x 3/4
18	820175	Washer Rubber
19	825547	Drum Drive
20	509547	Coupling
21	9416712	* Washer 3/16 x 5/8 x 1/16
22	114603	* Lockwasher Ext. #10

\* Standard Hardware Item - May be purchased locally