

36-45 IN-LBS.
OF TORQUE
(42-52 CM-KG)
APPLY MEDIUM
STRENGTH
THREAD LOCK

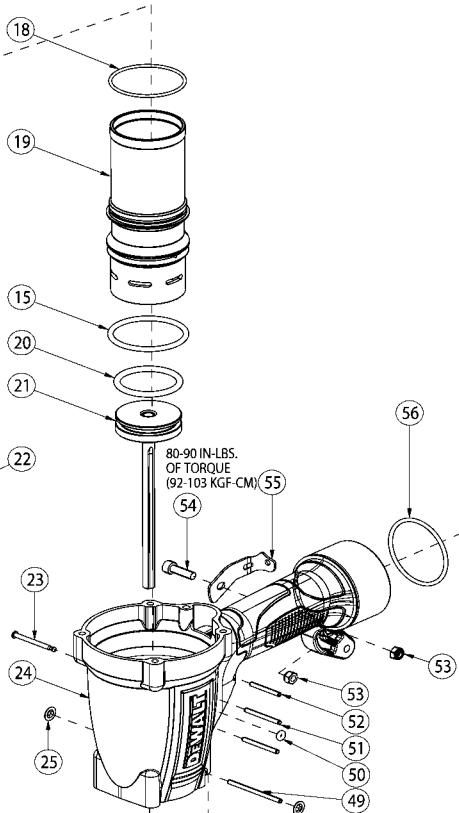
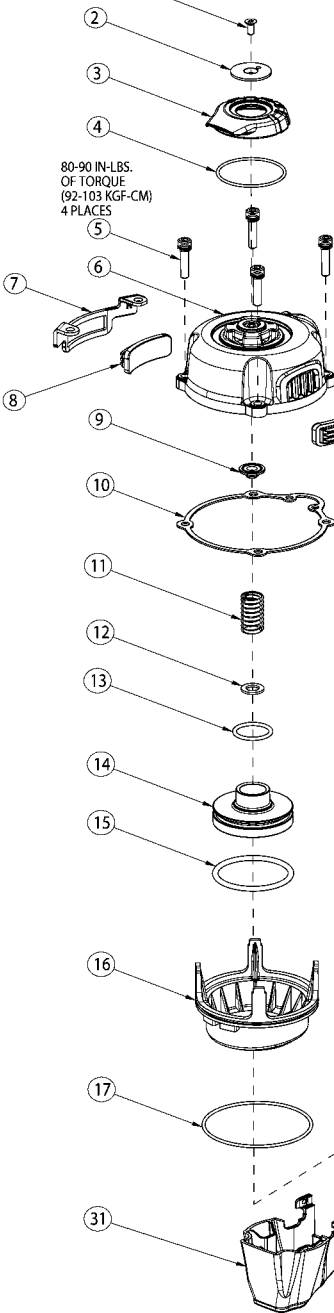

36-45 IN-LBS.
OF TORQUE
(42-52 CM-KG)
APPLY MEDIUM
STRENGTH
THREAD LOCK

145-155 IN-LBS.
OF TORQUE
(167-178 KGF-CM)
APPLY MEDIUM
STRENGTH
THREAD LOCK
4 PLACES

36-45 IN-LBS.
OF TORQUE
(42-52 CM-KG)
APPLY MEDIUM
STRENGTH
THREAD LOCK

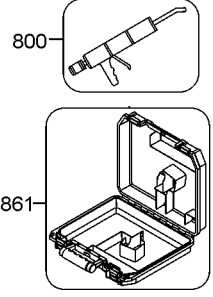

Parts List for DWMC150 Type 1

Item Number	Part Number	Description	Qty Required
1	174041	SCREW-SFHCS-M4X0.7X1	1
2	174042	SPACER-EXHAUST COVER	1
3	174043	COVER-EXHAUST	1
4	174044	O-RING-41.0MMX1.78MM	1
5	195071	SHCS, M5X0.8X25,SW	4
6	9R203795	CAP ASSEMBLY	1
7	9R203794	RH CAP BRACKET	1
8	9R203791	RUBBER PAD	2
9	174049	SEAL-DEFLECTOR	1
10	9R203793	GASKET- FRAME CAP	1
11	174051	SPRING-COMPRESSION	1
12	174052	WASHER-SPECIAL	1
13	174053	O-RING-20.8MMX2.4MM	1
14	174054	PISTON-HEAD VALVE	1
15	174055	O-RING-44.7MMX3.5MM	2
16	174057	COLLAR-CYLINDER SLEE	1
17	174056	O-RING-66.5MMX2.0MM	1
18	174058	O-RING-45.5MMX2.0MM	1
19	174059	SLEEVE-CYLINDER	1
20	174060	O-RING-36.0MMX4.0MM	1
21	174061	ASSEMBLY-DRIVER/PIST	1
22	9R203792	LH CAP BRACKET	1
23	174062	STEPPED PIN	1
24	9R203805	FRAME	1
25	174087	FIXED PLUG	2
26	174075	BUMPER-PISTON STOP	1
27	851483-S	O-RING	1

Parts List for DWMC150 Type 1

Item Number	Part Number	Description	Qty Required
28	174077	ASSEMBLY-NOSE	1
29	174081	FOLLOWER-MOVABLE NOS	1
30	174080	SCREW-SHCS-M4X0.7X8	1
31	174079	COVER-NOSE	1
32	174082	SPRING-COMPRESSION	1
33	174078	SCREW-SHCS-M6X1.0X25	4
34	174083	NOSE-MOVABLE	1
35	174069	SCREW-SHCS-M4X0.7X10	3
36	174088	SPACER-MAGAZINE	1
37	174090	MAGAZINE	1
38	174096	ASSEMBLY-PUSHER	1
39	174095	ASSEMBLY-PUSHER SPRI	1
40	174094	SCREW-SBHCS-M5X0.8X1	1
41	174093	WASHER-SPECIAL	1
42	174091	COVER-MAGAZINE	1
43	174092	PIN-SPECIAL	1
44	174089	LINER-NAIL GUIDE	1
45	174085	BRACKET-CT HOUSING	1
46	174084	ASSEMBLY-CT HOUSING	1
47	174072	ASSEMBLY-TRIGGER	1
48	TVA14	KIT-TRIGGER VALVE	1
49	174086	PIN-SPRING-M3X45MM	1
50	174073	O-RING	1
51	100298	PIN-SPIRAL M3X30	2
52	195514	SPRING PIN	1
53	174065	NUT-NYLON LOCK-M5X0.	2
54	174064	SCREW-SHCS-M5X0.8X18	1

Parts List for DWMC150 Type 1

Item Number	Part Number	Description	Qty Required
55	174066	BRACKET-END CAP	1
56	850242	O-RING-1.799X.103	1
57	175561	CAP-END	1
58	175582	SEAT PLATE-HOOK	1
59	175583	HOOK	1
60	175557	O-RING-21.9MMX2.62MM	1
61	175585	CAP-HOOK	1
62	175586	RING-RETAINING	1
64	9R208231	MODEL/FASTENER LABEL	1
65	9R208234	WARNING LABEL	1
800	100679	LUBE (1LB.CAN)	1
800	100653	LUBE (2CC)	1
861	9R208207	CARRY CASE	1