

RYOBI DETAIL SANDER – MODEL NUMBER DS1100

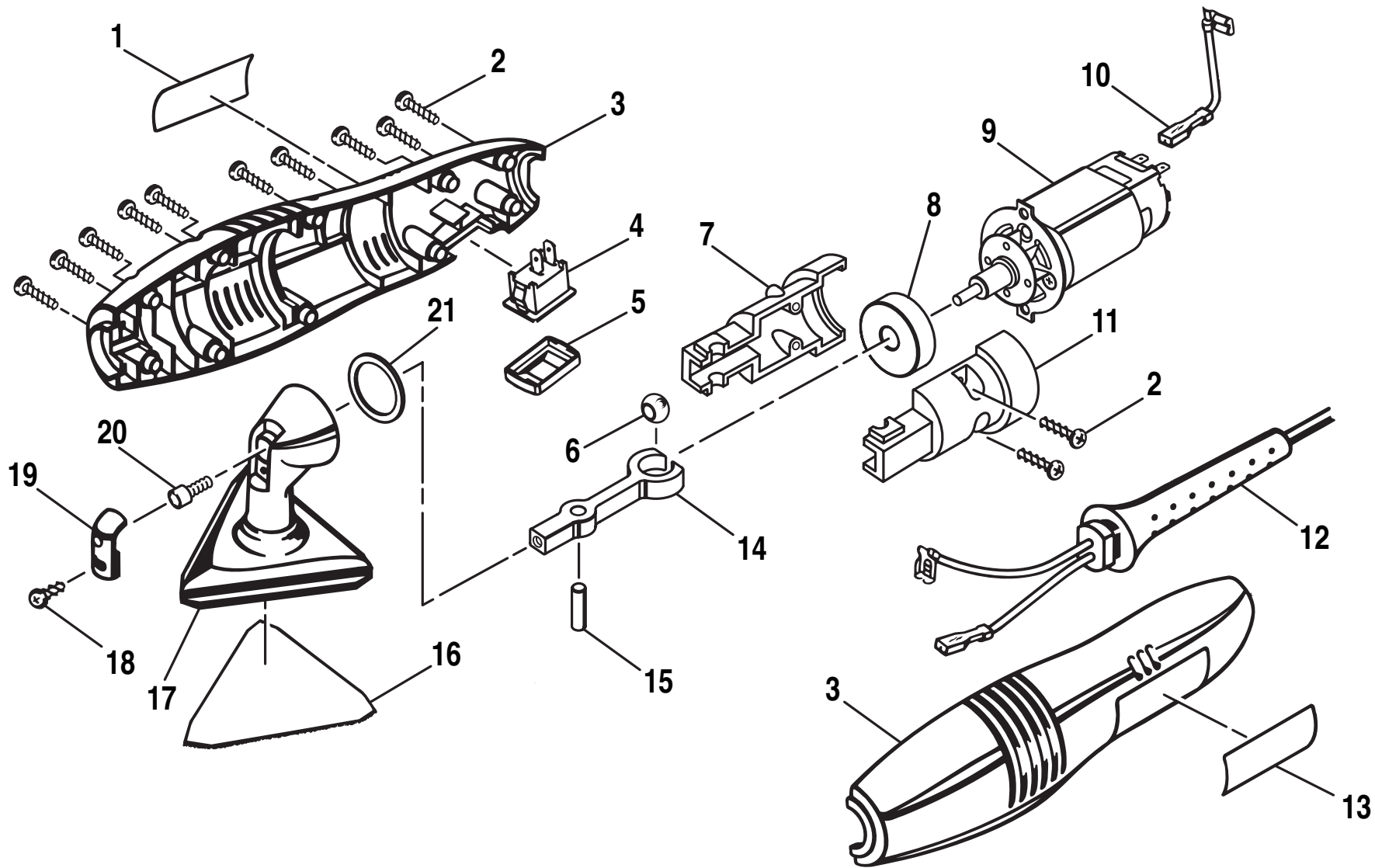

**WARNING:**

The foot cover, key number 20, insulates the cap screw, key number 21, making it part of the double insulated system. Therefore, it must always be replaced when replacing parts or making repairs to this tool.

## RYOBI DETAIL SANDER – MODEL NUMBER DS1100

The model number will be found on a plate attached to the motor housing. Always mention the model number in all correspondence regarding your **DETAIL SANDER** or when ordering repair parts.

### PARTS LIST

Key No.	Part Number	Description	Quan.	Key No.	Part Number	Description	Quan.
1	975860-001	DATA PLATE .....	1	13	973392-001	LOGO PLATE .....	1
2	990908-009	SCREW (#6-19 X 5/8 IN. PAN HD.) .....	12	14	975627-001	ARM .....	1
3	972031-000	HOUSING ASSEMBLY .....	1	15	975784-001	DOWEL PIN .....	1
4	968303-102	SWITCH ASSEMBLY (INC. KEY NO. 5) .....	1	16	971884-000	SANDPAPER .....	1
5	971443-001	SWITCH COVER .....	1	17	971654-001	RUBBER PAD .....	1
6	972983-002	SPHERICAL RING .....	1	18	972055-001	FOOT W/PAD (INCLUDES KEY NO. 17) .....	1
7	975625-001	ARM SUPPORT .....	1	19	967273-001	SCREW (#4-24 X 3/8 IN. PAN HD.) .....	1
8	972410-001	SLEEVE BEARING .....	1	20	971646-001	FOOT COVER .....	1
9	969808-013	MOTOR ASSEMBLY (INC. KEY NO. 8) .....	1	21	612284-003	CAP SCREW (#8-32 X 7/16 IN. HEX SOCKET) .....	1
10	971660-001	BLACK LEAD .....	1	22	979860-001	RUBBER WASHER .....	1
11	975626-001	ARM COVER .....	1		972000-426	OWNER'S MANUAL	
12	970777-014	CORD ASSEMBLY .....	1		9-98		

 **WARNING:**

**IMPROPER REPAIR OF A DOUBLE INSULATED TOOL CAN RESULT IN DAMAGES TO THE DOUBLE INSULATION SYSTEM POSSIBLY CAUSING ELECTRICAL SHOCK OR ELECTROCUTION. ANY REPAIRS REQUIRING DISASSEMBLY OF YOUR TOOL REQUIRES SAFETY TESTING AND SHOULD ONLY BE PERFORMED BY A RYOBI AUTHORIZED SERVICE CENTER OR OTHER QUALIFIED SERVICE ORGANIZATION.**