

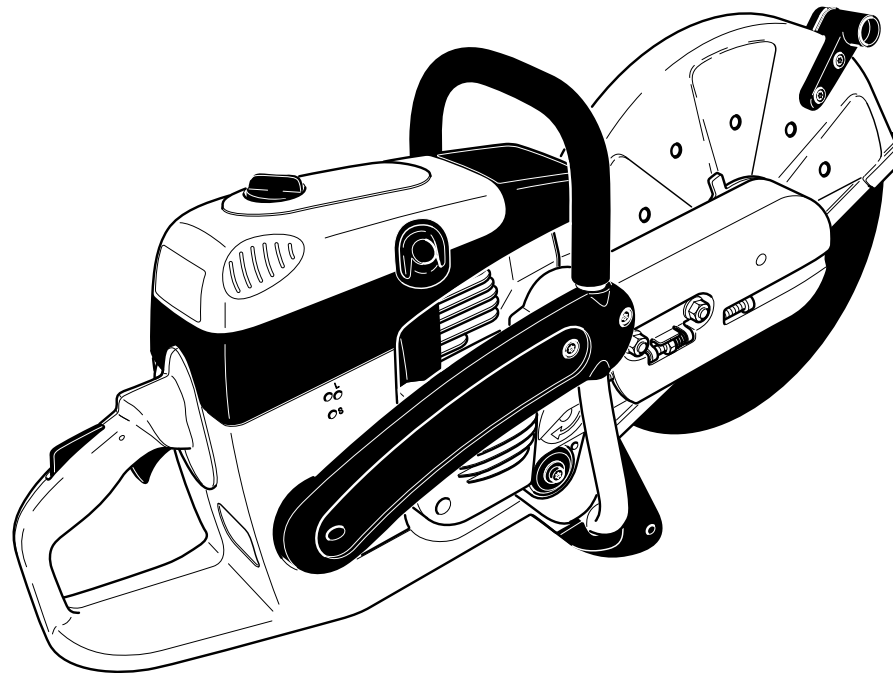

Spare Parts List
Ersatzteilliste
Liste de pièces détachées
Lista de piezas de repuesto

2014-04



- DPC6430
- DPC6431
- DPC7330
- DPC7331
- DPC8131
- DPC8132
- DPC6440
- DPC6441
- DPC7340
- DPC7341
- DPC6430 (UK)
- DPC7331 (UK)
- DPC8131 (UK)
- DPC8132 (UK)
- DPC6440 (UK)
- DPC7341 (UK)
- DPC6430 (USA)
- DPC6431 (USA)
- DPC7330 (USA)
- DPC7331 (USA)
- DPC8131 (USA)
- DPC8132 (USA)
- DPC6440 (USA)
- DPC6441 (USA)
- DPC7340 (USA)
- DPC7341 (USA)

995700585 (D, GB, F, E)

DPC6430, DPC6431, DPC7330, DPC7331, DPC8131,
 DPC8132, DPC6440, DPC6441, DPC7340, DPC7341,
 DPC6430, DPC7331, DPC8131, DPC8132, DPC6440
 , DPC7341 , DPC6430 , DPC6431 , DPC7330 , DPC7331
 , DPC8131 , DPC8132 , DPC6440 , DPC6441 ,
 DPC7340 , DPC7341

1

Tankeinheit und Handgriffe
 Tank and handle grips
 Réservoir et poignées
 Depósito y mangos

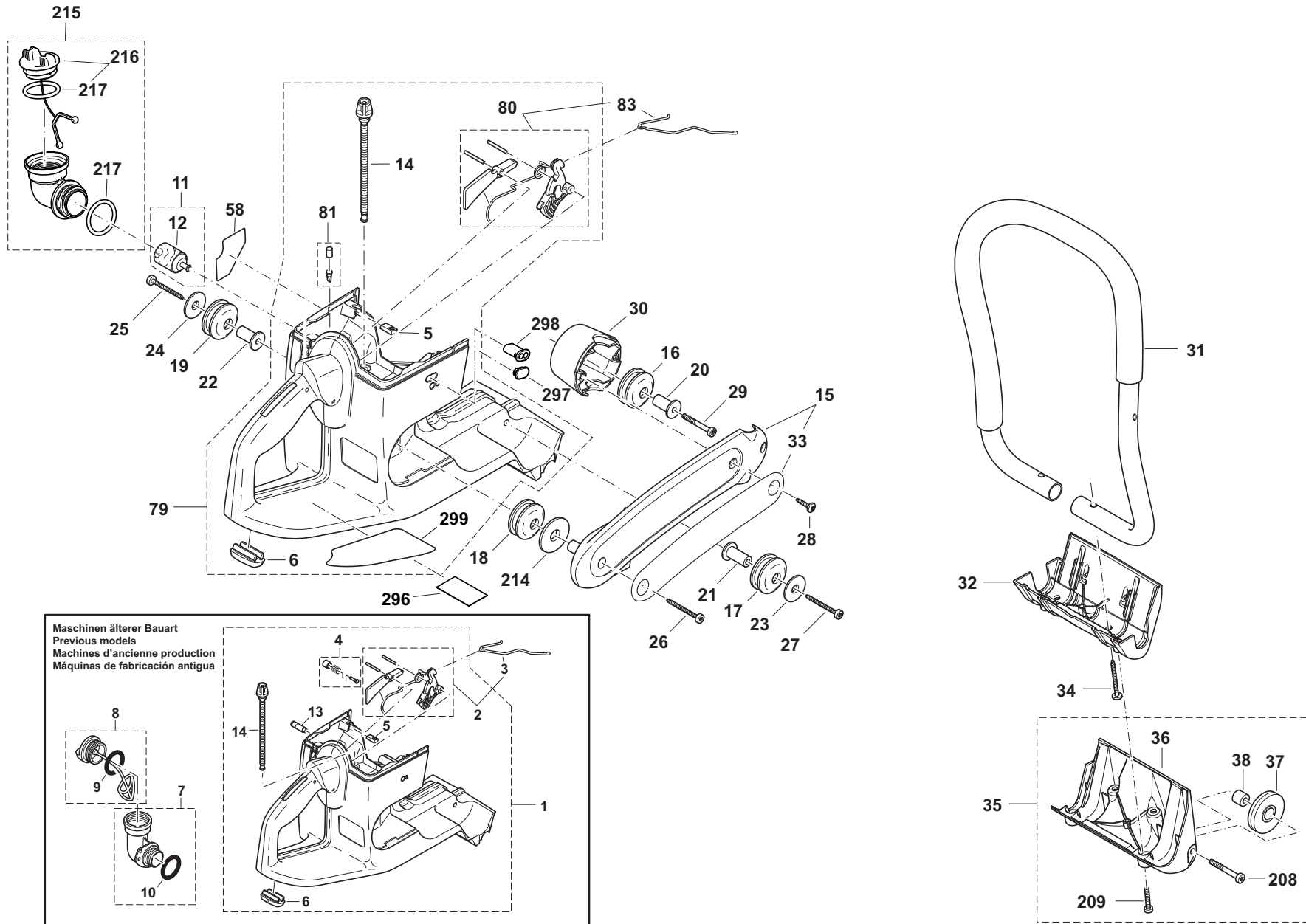

DPC6430, DPC6431, DPC7330, DPC7331, DPC8131, DPC8132, DPC6440, DPC6441, DPC7340, DPC7341, DPC6430, DPC7331, DPC8131, DPC8132, DPC6440, DPC7341, DPC6430, DPC6431, DPC7330, DPC7331, DPC8131, DPC8132, DPC6440, DPC6441, DPC7340, DPC7341

1

Tankeinheit und Handgriffe
Tank and handle grips
Réservoir et poignées
Depósito y mangos



Seite / Page	Pos.	DPC6430	DPC6431	DPC7330	DPC7331	DPC8131	DPC8132	DPC6440	DPC6441	DPC7340	DPC7341	DPC6430 (UK)	DPC7331 (UK)	DPC8131 (UK)	DPC8132 (UK)	DPC6440 (UK)	DPC7341 (UK)	DPC6430 (USA)	DPC6431 (USA)	DPC7330 (USA)	DPC7331 (USA)	DPC8131 (USA)	DPC8132 (USA)	DPC6440 (USA)	DPC6441 (USA)	DPC7340 (USA)	DPC7341 (USA)	Teil-Nr. Part No. No. de pièce No. de pieza	Hinweise Notes Renseign. Nota	Bezeichnung	Spezifikation Specification	Description	Désignation	Denominación
1	1	1	1	1	1	1	1	1	1	1	1	1	1	1	1	1	1	1	1	1	1	1	1	1	1	1	1	394 114 605		TANK KPL. MIT MECHANIK, BLAU	=> 2009	TANK CPL., BLUE	RÉSERVOIR CPL., BLEU	DEPÓSITO CPL.
1	2	1	1	1	1	1	1	1	1	1	1	1	1	1	1	1	1	1	1	1	1	1	1	1	1	1	1	957 117 020		GASMECHANIK KPL.	INC. 3	THROTTLE MECHANISM, CPL.	MÉCANIQUE DE DÉCLEN. CPL.	MECANISMO ACELERADOR, CPL.
1	3	1	1	1	1	1	1	1	1	1	1	1	1	1	1	1	1	1	1	1	1	1	1	1	1	1	1	394 117 011		GASGESTÄNGE		THROTTLE LINKAGE	TRINGLE D'ACCÉLÉRATION	VARILLA ACELERADOR
1	4	1	1	1	1	1	1	1	1	1	1	1	1	1	1	1	1	1	1	1	1	1	1	1	1	1	1	957 117 030		HALBGASARR ETIERUNG KPL.		HALF-THROTTLE LOCK, CPL.	DISPOS. D'ARRÊT DEMI-GAZ CPL.	BLOQUEO MEDIO GAS, CPL.
1	5	4	4	4	4	4	4	4	4	4	4	4	4	4	4	4	4	4	4	4	4	4	4	4	4	4	4	394 114 100		SCHRAUBEINSAATZ		SCREW PLUG	EMBOUT DE VISSAGE	ALOJAMIENTO DE TORNILLOS
1	6	1	1	1	1	1	1	1	1	1	1	1	1	1	1	1	1	1	1	1	1	1	1	1	1	1	1	394 114 070		GUMMIFUß		RUBBER FOOT	PIED, CAOTCHOUC	PIE, GOMA
1	7	1	1	1	1	1	1	1	1	1	1	1	1	1	1	1	1	1	1	1	1	1	1	1	1	1	1	010 114 081	Acc.	WINKELTANKVERSCHLUß KPL.	INC. 10	ANGULAR UNION ASSY.	MANCHON COUDÉ CPL.	CIERRE ANGULAR CPL.
1	8	1	1	1	1	1	1	1	1	1	1	1	1	1	1	1	1	1	1	1	1	1	1	1	1	1	1	010 114 091		TANKDECKEL KPL., KRAFTSTOFF	INC. 9	TANK CAP CPL.	BOUCHON RÉSERVOIR CPL.	CIERRE DEPÓSITO CPL.
1	9	1	1	1	1	1	1	1	1	1	1	1	1	1	1	1	1	1	1	1	1	1	1	1	1	1	1	963 230 031		O-RING, ROT	ø30x3	O-RING, RED	BAGUE JOINT, ROUGE	ANILLO DE GUARNICIÓN, ROJO
1	10	1	1	1	1	1	1	1	1	1	1	1	1	1	1	1	1	1	1	1	1	1	1	1	1	1	1	963 230 031	Acc.	O-RING, ROT	ø30x3	O-RING, RED	BAGUE JOINT, ROUGE	ANILLO DE GUARNICIÓN, ROJO
1	11	1	1	1	1	1	1	1	1	1	1	1	1	1	1	1	1	1	1	1	1	1	1	1	1	1	1	010 114 010		SAUGKOPF KPL.	INC. 12	SUCTION HEAD	TÊTE D'ASPIRATION	CABEZA DE ASPIRACION
1	12	1	1	1	1	1	1	1	1	1	1	1	1	1	1	1	1	1	1	1	1	1	1	1	1	1	1	010 114 020		REPARATURSAATZ, FILTER (JE 5 STCK.)	for 010114010	REP. KIT, FILTER (5 OF EACH)	JEU DE RÉPARAT., FILTRE	JUEGO DE REPARAR, FILTRO
1	13	1	1	1	1	1	1	1	1	1	1	1	1	1	1	1	1	1	1	1	1	1	1	1	1	1	1	010 175 050		BELÜFTUNGSVENTIL KPL.		AIR VALVE CPL.	SOUPAPE D'AERATION CPL.	VÁLVULA VENTILACION CPL.
1	14	1	1	1	1	1	1	1	1	1	1	1	1	1	1	1	1	1	1	1	1	1	1	1	1	1	1	965 404 913		SAUGSCHLAUCH KRAFTSTOFF	EPA code	FUEL LINE	CONDUITE CARB.	TUBO COMB.

DPC6430, DPC6431, DPC7330, DPC7331, DPC8131,
 DPC8132, DPC6440, DPC6441, DPC7340, DPC7341,
 DPC6430, DPC7331, DPC8131, DPC8132, DPC6440
 , DPC7341 , DPC6430 , DPC6431 , DPC7330 , DPC7331
 , DPC8131 , DPC8132 , DPC6440 , DPC6441 ,
 DPC7340 , DPC7341

1

Tankeinheit und Handgriffe
 Tank and handle grips
 Réservoir et poignées
 Depósito y mangos

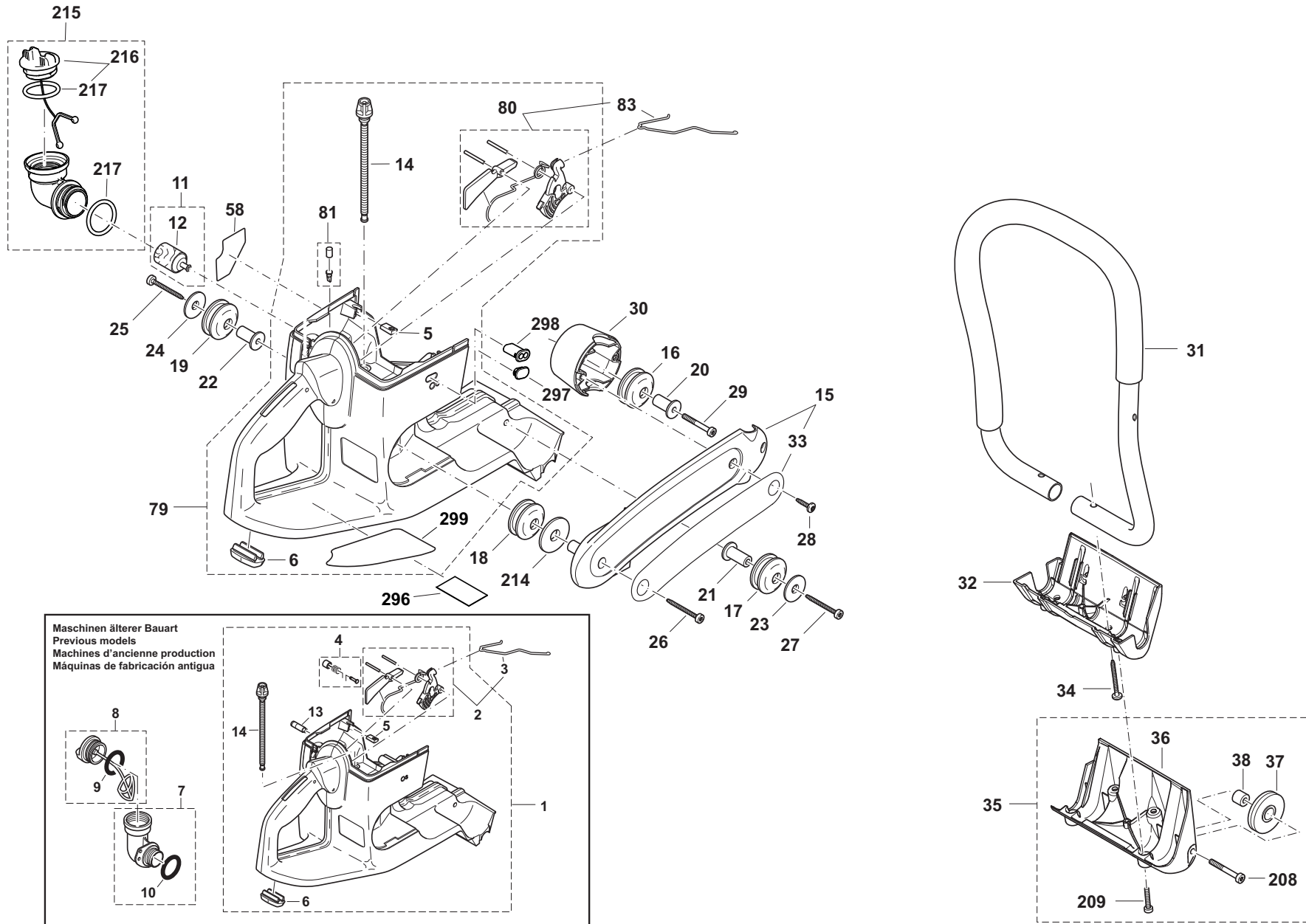

DPC6430, DPC6431, DPC7330, DPC7331, DPC8131, DPC8132, DPC6440, DPC6441, DPC7340, DPC7341, DPC6430, DPC7331, DPC8131, DPC8132, DPC6440, DPC7341, DPC6430, DPC6431, DPC7330, DPC7331, DPC8131, DPC8132, DPC6440, DPC6441, DPC7340, DPC7341

1

Tankeinheit und Handgriffe
Tank and handle grips
Réservoir et poignées
Depósito y mangos



Seite / Page	Pos.	DPC6430	DPC6431	DPC7330	DPC7331	DPC8131	DPC8132	DPC6440	DPC6441	DPC7340	DPC7341	DPC6430 (UK)	DPC7331 (UK)	DPC8131 (UK)	DPC8132 (UK)	DPC6440 (UK)	DPC7341 (UK)	DPC6430 (USA)	DPC6431 (USA)	DPC7330 (USA)	DPC7331 (USA)	DPC8131 (USA)	DPC8132 (USA)	DPC6440 (USA)	DPC6441 (USA)	DPC7340 (USA)	DPC7341 (USA)	Teil-Nr. Part No. No. de pièce No. de pieza	Hinweise Notes Renseign. Nota	Bezeichnung	Spezifikation Specification	Description	Désignation	Denominación
1	15	1	1	1	1	1	1	1	1	1	1	1	1	1	1	1	1	1	1	1	1	1	1	1	1	1	1	394 114 661		SEITENSTREBE	MAKITA, grey	BRACKET	SUPPORT	SOPORTE
1	15	1	1	1	1	1	1	1	1	1	1	1	1	1	1	1	1	1	1	1	1	1	1	1	1	1	395 310 600	2010 =>	SEITENSTREBE, GEÄTZT	MAKITA, black, etched	BRACKET	SUPPORT	SOPORTE	
1	16	1	1	1	1	1	1	1	1	1	1	1	1	1	1	1	1	1	1	1	1	1	1	1	1	1	965 403 535		SCHWINGUNGSDÄMPFER		RUBBER BUFFER	AMORTISSEUR	AMORTIGUADOR	
1	17	1	1	1	1	1	1	1	1	1	1	1	1	1	1	1	1	1	1	1	1	1	1	1	1	1	965 403 535		SCHWINGUNGSDÄMPFER		RUBBER BUFFER	AMORTISSEUR	AMORTIGUADOR	
1	18	1	1	1	1	1	1	1	1	1	1	1	1	1	1	1	1	1	1	1	1	1	1	1	1	1	965 403 535		SCHWINGUNGSDÄMPFER		RUBBER BUFFER	AMORTISSEUR	AMORTIGUADOR	
1	19	1	1	1	1	1	1	1	1	1	1	1	1	1	1	1	1	1	1	1	1	1	1	1	1	1	965 403 535		SCHWINGUNGSDÄMPFER		RUBBER BUFFER	AMORTISSEUR	AMORTIGUADOR	
1	20	1	1	1	1	1	1	1	1	1	1	1	1	1	1	1	1	1	1	1	1	1	1	1	1	1	394 114 281		ACHSE FÜR DÄMPFER		AXLE	AXE	EJE	
1	21	1	1	1	1	1	1	1	1	1	1	1	1	1	1	1	1	1	1	1	1	1	1	1	1	1	394 114 281		ACHSE FÜR DÄMPFER		AXLE	AXE	EJE	
1	22	1	1	1	1	1	1	1	1	1	1	1	1	1	1	1	1	1	1	1	1	1	1	1	1	1	394 114 281		ACHSE FÜR DÄMPFER		AXLE	AXE	EJE	
1	23	1	1	1	1	1	1	1	1	1	1	1	1	1	1	1	1	1	1	1	1	1	1	1	1	1	900 005 078		ANLAGESCHEIBE		WASHER	RONDELLE	ARANDELA	
1	24	1	1	1	1	1	1	1	1	1	1	1	1	1	1	1	1	1	1	1	1	1	1	1	1	1	900 005 078		ANLAGESCHEIBE		WASHER	RONDELLE	ARANDELA	
1	25	1	1	1	1	1	1	1	1	1	1	1	1	1	1	1	1	1	1	1	1	1	1	1	1	1	913 455 454		SCHRAUBE	5,5x45	SCREW	VIS	TORNILLO	
1	26	1	1	1	1	1	1	1	1	1	1	1	1	1	1	1	1	1	1	1	1	1	1	1	1	1	913 455 454		SCHRAUBE	5,5x45	SCREW	VIS	TORNILLO	
1	27	1	1	1	1	1	1	1	1	1	1	1	1	1	1	1	1	1	1	1	1	1	1	1	1	1	913 455 454		SCHRAUBE	5,5x45	SCREW	VIS	TORNILLO	
1	28	2	2	2	2	2	2	2	2	2	2	2	2	2	2	2	2	2	2	2	2	2	2	2	2	2	2	913 455 204		SCHRAUBE INNEN6RD ZK	5,5x20	SCREW	VIS	TORNILLO
1	29	1	1	1	1	1	1	1	1	1	1	1	1	1	1	1	1	1	1	1	1	1	1	1	1	1	908 305 405		SCHRAUBE INNEN6RD ZK	M5x40	H.L. SOCKET HEAD BOLT	VIS	TORNILLO	
1	30	1	1	1	1	1	1	1	1	1	1	1	1	1	1	1	1	1	1	1	1	1	1	1	1	1	395 310 020	2010 =>	AUFNAHMETOPF, SCHWARZ, GEÄTZT	black, etched	POT	CAPUCHON	POTE	
1	30	1	1	1	1	1	1	1	1	1	1	1	1	1	1	1	1	1	1	1	1	1	1	1	1	1	394 114 051		AUFNAHMETOPF FÜR DÄMPFER, GRAU		POT	CAPUCHON	POTE	
1	31	1	1	1	1	1	1	1	1	1	1	1	1	1	1	1	1	1	1	1	1	1	1	1	1	1	394 310 101		RUNDUMGRIFF KPL.		WRAP AROUND HANDLE ASSY.	POIGNÉE CIRCULAIRE CPL.	MANGO CIRCULAR CPL.	
1	32	1	1	1	1	1	1	1	1	1	1	1	1	1	1	1	1	1	1	1	1	1	1	1	1	1	395 250 020		STANDFUSS		STAND SET	PIED	PIE	

DPC6430, DPC6431, DPC7330, DPC7331, DPC8131,
 DPC8132, DPC6440, DPC6441, DPC7340, DPC7341,
 DPC6430, DPC7331, DPC8131, DPC8132, DPC6440
 , DPC7341 , DPC6430 , DPC6431 , DPC7330 , DPC7331
 , DPC8131 , DPC8132 , DPC6440 , DPC6441 ,
 DPC7340 , DPC7341

1

Tankeinheit und Handgriffe
 Tank and handle grips
 Réservoir et poignées
 Depósito y mangos

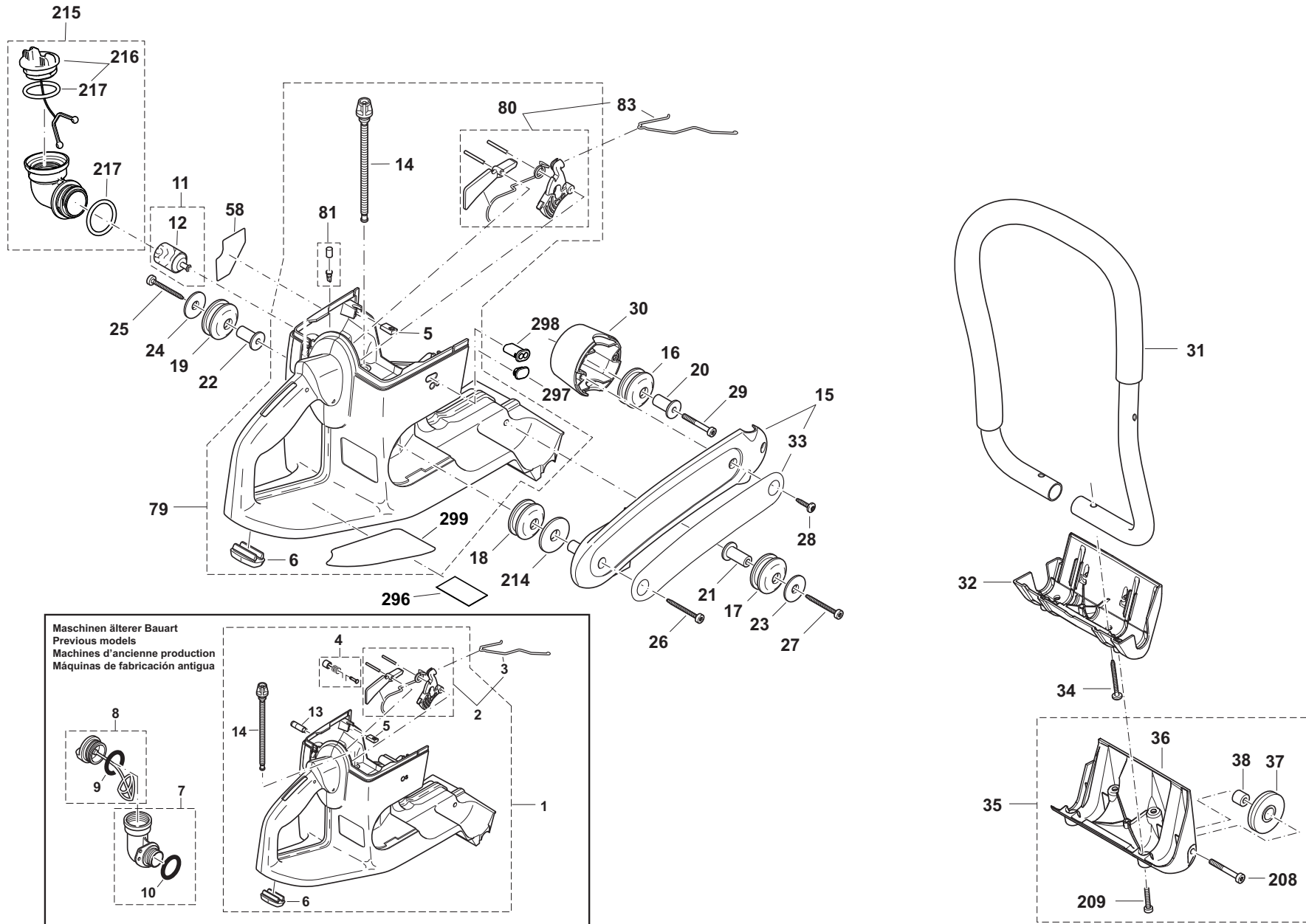

DPC6430, DPC6431, DPC7330, DPC7331, DPC8131, DPC8132, DPC6440, DPC6441, DPC7340, DPC7341, DPC6430, DPC7331, DPC8131, DPC8132, DPC6440, DPC7341, DPC6430, DPC6431, DPC7330, DPC7331, DPC8131, DPC8132, DPC6440, DPC6441, DPC7340, DPC7341

1

Tankeinheit und Handgriffe
Tank and handle grips
Réservoir et poignées
Depósito y mangos



Seite / Page	Pos.	DPC6430	DPC6431	DPC7330	DPC7331	DPC8131	DPC8132	DPC6440	DPC6441	DPC7340	DPC7341	DPC6430 (UK)	DPC7331 (UK)	DPC8131 (UK)	DPC8132 (UK)	DPC6440 (UK)	DPC7341 (UK)	DPC6430 (USA)	DPC6431 (USA)	DPC7330 (USA)	DPC7331 (USA)	DPC8131 (USA)	DPC8132 (USA)	DPC6440 (USA)	DPC6441 (USA)	DPC7340 (USA)	DPC7341 (USA)	Teil-Nr. Part No. No. de pièce No. de pieza	Hinweise Notes Renseign. Nota	Bezeichnung	Spezifikation Specification	Description	Désignation	Denominación	
1	33	1	1	1	1	1	1	1	1	1	1	1	1	1	1	1	1	1	1	1	1	1	1	1	1	1	1	1	980 115 215		SCHILD	MAKITA	LABEL	PLAQUE	CALCOMANIA
1	34	2	2	2	2	2	2	2	2	2	2	2	2	2	2	2	2	2	2	2	2	2	2	2	2	2	2	2	913 455 454		SCHRAUBE	5,5x45	SCREW	VIS	TORNILLO
1	35	1	1	1	1	1	1	1	1	1	1	1	1	1	1	1	1	1	1	1	1	1	1	1	1	1	1	394 114 272	Acc.	STANDFUß MIT ROLLEN KPL.	INC. 36-38,208,209	FOOT CPL.	PIED CPL.	PIE CPL.	
1	36						1							1														394 114 252		STANDFUß		FOOT	PIED	PIE	
1	37	2	2	2	2	2	2	2	2	2	2	2	2	2	2	2	2	2	2	2	2	2	2	2	2	2	2	394 114 230	Acc.	ROLLE		ROLLER	ROULEAU	RUEDA	
1	38	2	2	2	2	2	2	2	2	2	2	2	2	2	2	2	2	2	2	2	2	2	2	2	2	2	2	394 114 240	Acc.	BUCHSE		BUSHING	DOUILLE	CASQUILLO	
1	58																	1	1	1	1	1	1	1	1	1	1	1	980 115 100		AUFKLEBER	MIX, USA-CDN-AUS	LABEL	ÉTIQUETTE	ETIQUETA
1	79	1	1	1	1	1	1	1	1	1	1	1	1	1	1	1	1											395 114 600	2010 =>	TANK KPL. MIT MECHANIK	blue, highly polishedINC. 5,6,14,80,81,299	TANK CPL.	RÉSERVOIR CPL.	DEPÓSITO CPL.	
1	79	1	1	1	1	1	1	1	1	1	1	1	1	1	1	1	1											395 114 602	2012-04 =>	TANK KPL. MIT MECHANIK	blue, highly polishedINC. 5,6,14,80,81,299	TANK CPL.	RÉSERVOIR CPL.	DEPÓSITO CPL.	
1	79																	1	1	1	1	1	1	1	1	1	1	395 114 641		TANK KPL. MIT MECHANIK, BLAU	USA (EPA), INC.296INC. 5,6,14,80,81,269,299	TANK CPL., BLUE	RÉSERVOIR CPL., BLEU	DEPÓSITO CPL., AZUL	
1	80	1	1	1	1	1	1	1	1	1	1	1	1	1	1	1	1	1	1	1	1	1	1	1	1	1	1	957 117 040		GASMECHANIK KPL.	INC. 83	THROTTLE MECHANISM, CPL.	MÉCANIQUE DE DÉCLEN. CPL.	MECANISMO ACELERADOR, CPL.	
1	81	1	1	1	1	1	1	1	1	1	1	1	1	1	1	1	1	1	1	1	1	1	1	1	1	1	1	170 175 010		SATZ BELÜFTUNGSVENTIL		AIR VALVE CPL.	SOUPAPE D'AERATION CPL.	VÁLVULA VENTILACION CPL.	
1	83	1	1	1	1	1	1	1	1	1	1	1	1	1	1	1	1	1	1	1	1	1	1	1	1	1	1	395 117 011		GASGESTÄNGE		THROTTLE LINKAGE	TRINGLE D'ACCÉLÉRATION	VARILLA ACELERADOR	
1	208	2	2	2	2	2	2	2	2	2	2	2	2	2	2	2	2	2	2	2	2	2	2	2	2	2	2	908 006 356	Acc.	SCHRAUBE	M6X35	SCREW	VIS	TORNILLO	
1	209	4	4	4	4	4	4	4	4	4	4	4	4	4	4	4	4	4	4	4	4	4	4	4	4	4	4	908 905 165		INNENSTERN-SCHRAUBE	5x16	SCREW	VIS	TORNILLO	
1	214	1	1	1	1	1	1	1	1	1	1	1	1	1	1	1	1	1	1	1	1	1	1	1	1	1	1	900 005 076		ANLAGESCHEIBE		WASHER	RONDELLE	ARANDELA	
1	215	1	1	1	1	1	1	1	1	1	1	1	1	1	1	1	1	1	1	1	1	1	1	1	1	1	1	395 114 300	Acc.	WINKELTANKVERSCHLUß KPL.	INC. 216,217	ANGULAR UNION ASSY.	MANCHON COUDÉ CPL.	CIERRE ANGULAR CPL.	
1	216	1	1	1	1	1	1	1	1	1	1	1	1	1	1	1	1	1	1	1	1	1	1	1	1	1	1	181 114 202		TANKDECKEL KPL.	INC. 217	TANK CAP CPL.	BOUCHON RESERVOIR CPL.	TORNILLO DE CIERRE CPL.	
1	217	2	2	2	2	2	2	2	2	2	2	2	2	2	2	2	2	2	2	2	2	2	2	2	2	2	2	963 229 036		O-RING	29,3X3,6	PACKING RING	BAGUE-JOINT	ANILLO DE GUARNICION	
1	296																	1	1	1	1	1	1	1	1	1	1			AUFKLEBER TANK	USA - EVAPORATION MAKITA	LABEL, TANK	PLAQUE, RÉSERVOIR	CALCOMANIA, DEPÓSITO	
1	297	1	1	1	1	1	1	1	1	1	1	1	1	1	1	1	1	1	1	1	1	1	1	1	1	1	1	395 114 040		VERSCHLUßSTÖPFEN	EU, USA	PLUG	BOUCHON	TAPON	

DPC6430, DPC6431, DPC7330, DPC7331, DPC8131,
 DPC8132, DPC6440, DPC6441, DPC7340, DPC7341,
 DPC6430, DPC7331, DPC8131, DPC8132, DPC6440
 , DPC7341 , DPC6430 , DPC6431 , DPC7330 , DPC7331
 , DPC8131 , DPC8132 , DPC6440 , DPC6441 ,
 DPC7340 , DPC7341

1

Tankeinheit und Handgriffe
 Tank and handle grips
 Réservoir et poignées
 Depósito y mangos

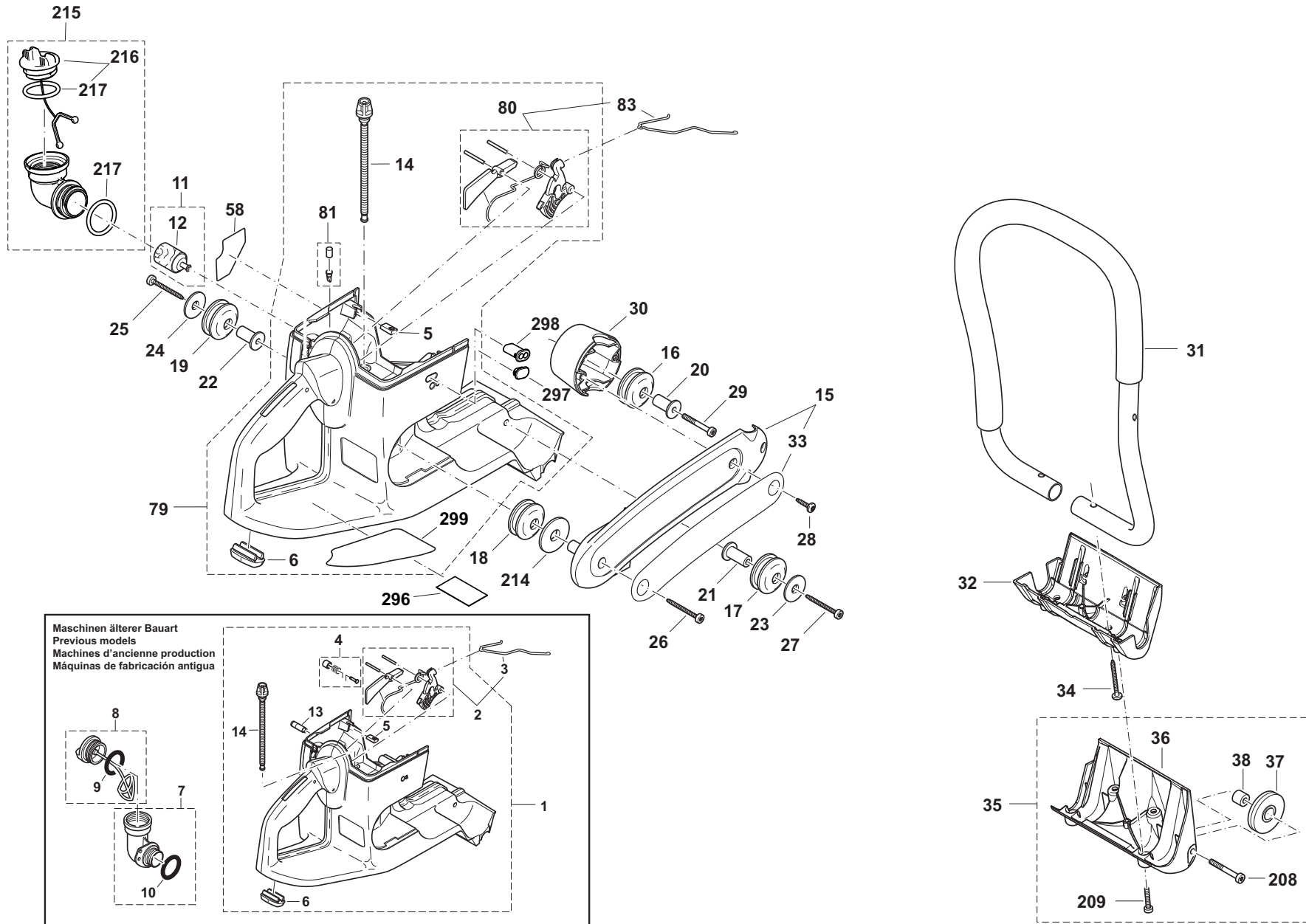

Maschinen älterer Bauart
 Previous models
 Machines d'ancienne production
 Máquinas de fabricación antigua

DPC6430, DPC6431, DPC7330, DPC7331, DPC8131,
 DPC8132, DPC6440, DPC6441, DPC7340, DPC7341,
 DPC6430, DPC7331, DPC8131, DPC8132, DPC6440
 , DPC7341, DPC6430, DPC6431, DPC7330, DPC7331
 , DPC8131, DPC8132, DPC6440, DPC6441,
 DPC7340, DPC7341

1

Tankeinheit und Handgriffe
 Tank and handle grips
 Réservoir et poignées
 Depósito y mangos



Seite / Page	Pos.	DPC6430	DPC6431	DPC7330	DPC7331	DPC8131	DPC8132	DPC6440	DPC6441	DPC7340	DPC7341	DPC6430 (UK)	DPC7331 (UK)	DPC8131 (UK)	DPC8132 (UK)	DPC6440 (UK)	DPC7341 (UK)	DPC6430 (USA)	DPC6431 (USA)	DPC7330 (USA)	DPC7331 (USA)	DPC8131 (USA)	DPC8132 (USA)	DPC6440 (USA)	DPC6441 (USA)	DPC7340 (USA)	DPC7341 (USA)	Teil-Nr. Part No. No. de pièce No. de pieza	Hinweise Notes Renseign. Nota	Bezeichnung	Spezifikation Specification	Description	Désignation	Denominación
1	298	1	1	1	1	1	1	1	1	1	1																	170 118 031		FÜHRUNG	H / L (non regulated market)	ADJUSTING GUIDE	GUIDAGE D'AJUSTAGE	GUÍA DE AJUSTE
1	299	1	1	1	1	1	1	1	1	1	1	1	1	1	1	1	1	1	1	1	1	1	1	1	1	1	1	980 115 699		AUFKLEBER	START	LABEL	ÉTIQUETTE	ETIQUETA

DPC6430, DPC6431, DPC7330, DPC7331, DPC8131,
DPC8132, DPC6440, DPC6441, DPC7340, DPC7341,
DPC6430, DPC7331, DPC8131, DPC8132, DPC6440
, DPC7341, DPC6430, DPC6431, DPC7330, DPC7331
, DPC8131, DPC8132, DPC6440, DPC6441,
DPC7340, DPC7341

2

Abdeckhaube, Luftfilter
Hood, air filter
Capot protecteur, filtre à air
Cubierta protectora, filtro de aire

Makita[®]

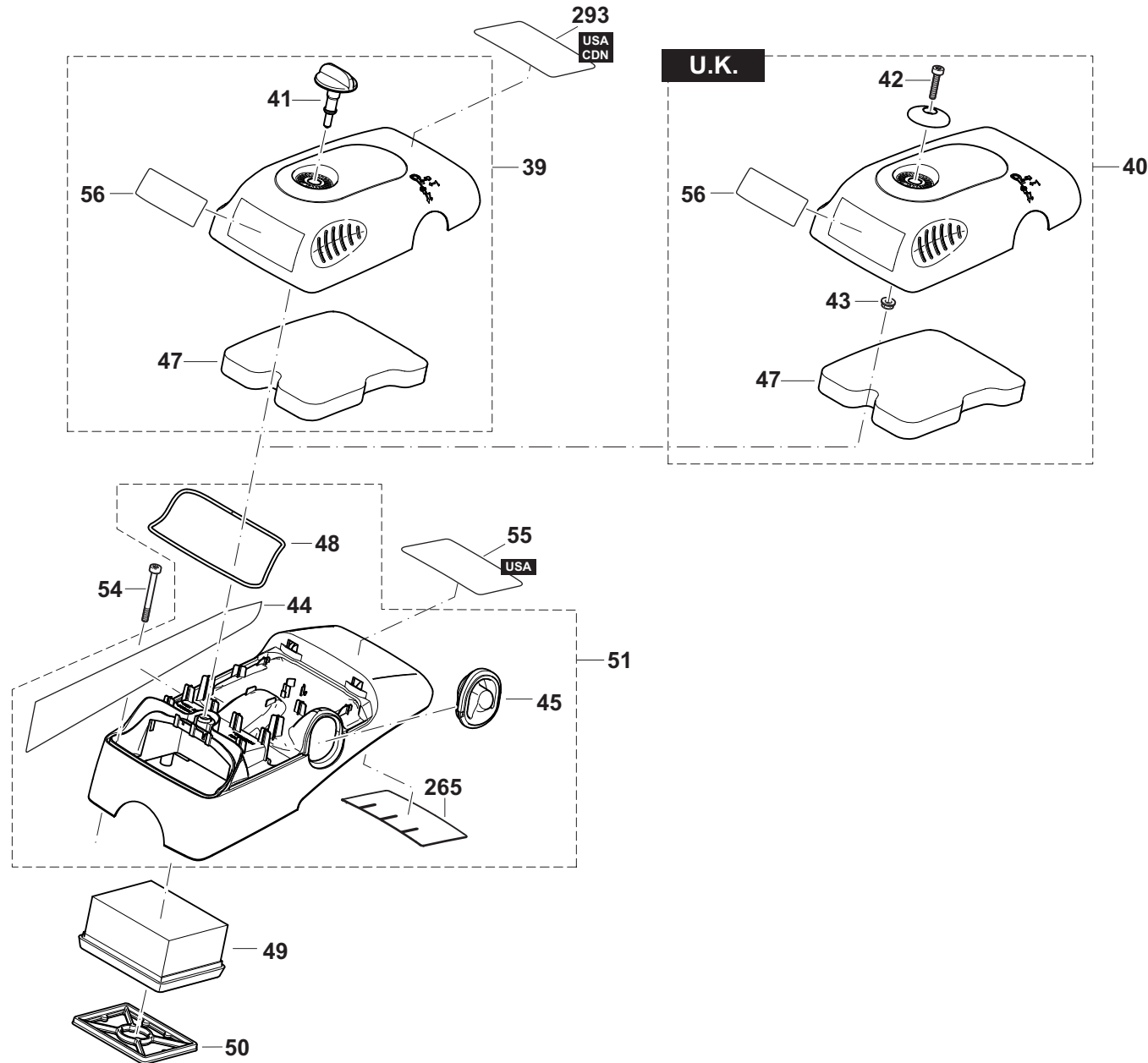

DPC6430, DPC6431, DPC7330, DPC7331, DPC8131, DPC8132, DPC6440, DPC6441, DPC7340, DPC7341, DPC6430, DPC7331, DPC8131, DPC8132, DPC6440, DPC7341, DPC6430, DPC6431, DPC7330, DPC7331, DPC8131, DPC8132, DPC6440, DPC6441, DPC7340, DPC7341

2

Abdeckhaube, Luftfilter
Hood, air filter
Capot protecteur, filtre à air
Cubierta protectora, filtro de aire



Seite / Page	Pos.	DPC6430	DPC6431	DPC7330	DPC7331	DPC8131	DPC8132	DPC6440	DPC6441	DPC7340	DPC7341	DPC6430 (UK)	DPC7331 (UK)	DPC8131 (UK)	DPC8132 (UK)	DPC6440 (UK)	DPC7341 (UK)	DPC6430 (USA)	DPC6431 (USA)	DPC7330 (USA)	DPC7331 (USA)	DPC8131 (USA)	DPC8132 (USA)	DPC6440 (USA)	DPC6441 (USA)	DPC7340 (USA)	DPC7341 (USA)	Teil-Nr. Part No. No. de pièce No. de pieza	Hinweise Notes Renseign. Nota	Bezeichnung	Spezifikation Specification	Descriptio n	Désignation	Denominación
2	39	1	1	1	1	1	1	1	1	1	1							1	1	1	1	1	1	1	1	1	1	395 118 122	2010 =>	FILTERDECKE L KPL., SCHWARZ, GEÄTZT	black, etchedINC. 41,47,56	COVER ASSY.	CAPOT CPL.	CUBIERTA CPL.
2	39	1	1	1	1	1	1																				395 118 190	RU 2010 =>	FILTERDECKE L KPL., SCHWARZ, GEÄTZT	black, etchedINC. 41,47,56	COVER ASSY.	CAPOT CPL.	CUBIERTA CPL.	
2	40											1	1	1	1	1	1											957 118 020	U.K. . 2010 =>	FILTERDECKE L KPL., SCHWARZ, GEÄTZT	black, etchedINC. 42,43,47,56	FILTER COVER ASSY.	CAPOT FILTRE CPL.	CUBIERTA P. FILTRE CPL.
2	40											1	1	1	1	1	1											395 118 660	U.K. => 2009	FILTERDECKE L KPL., GRAU	grey, w/o Pos. 47INC. 42,43,56	COVER ASSY.	CAPOT CPL.	CUBIERTA CPL.
2	41	1	1	1	1	1	1	1	1	1	1							1	1	1	1	1	1	1	1	1	1	395 118 010		VERSCHLUßKNOPF		FIXING	FERMETURE	CIERRE
2	42											1	1	1	1	1	1											395 118 131	U.K.	SENKKOPFSCHE HRAUBE	M6x50	COUNTERSUNK SCREW	BOULON À TÊTE FRAISÉE	TORNILLO DE CABEZA AVELLANADA
2	43											1	1	1	1	1	1											920 406 000	U.K.	SECHSKANTMUTTER	M6	HEX NUT	ECROU HEXAGONAL	TUERCA HEXAGONAL
2	44	1	1	1	1	1	1	1	1	1	1	1	1	1	1	1	1	1	1	1	1	1	1	1	1	1	1	980 115 870		SICHERHEITS AUFKLEBER		SAFETY LABEL	PLAQUE	CALCOMANIA
2	44	1	1	1	1	1	1																					980 115 902	RU	SICHERHEITS AUFKLEBER	RU	SAFETY LABEL	PLAQUE	CALCOMANIA
2	45	1	1	1	1	1	1	1	1	1	1	1	1	1	1	1	1	1	1	1	1	1	1	1	1	1	1	395 118 050		GUMMITEIL	DEKO	RUBBER PART	ÉLASTIQUE PART	PIEZA DE GOMA ELÁSTICA
2	47	1	1	1	1	1	1	1	1	1	1	1	1	1	1	1	1	1	1	1	1	1	1	1	1	1	1	395 173 081		VORFILTER		PREFILTER	PREFILTRE	PRIMER FILTRO
2	47					1	1						1	1								1	1					957 173 611		FILTERSET	5+1 MAKITAINC. 5x47 + 1x49	FILTER-SET	JEU DE FILTRE POUR DECOUPEUSE	JUEGO DE FILTROS CORTADORAS
2	48	1	1	1	1	1	1	1	1	1	1	1	1	1	1	1	1	1	1	1	1	1	1	1	1	1	1	395 118 021		DICHTSCHNUR		PACKING RING	BAGUE-JOINT	ANILLO DE GUARNICIÓN
2	49	1	1	1	1	1	1	1	1	1	1	1	1	1	1	1	1	1	1	1	1	1	1	1	1	1	1	395 173 011		LUFTFILTEREINSATZ		AIR FILTER	FILTRE À AIR	FILTRO DE AIRE
2	49				1	1								1	1							1	1					957 173 611		FILTERSET	5+1 MAKITAINC. 5x47 + 1x49	FILTER-SET	JEU DE FILTRE POUR DECOUPEUSE	JUEGO DE FILTROS CORTADORAS

DPC6430, DPC6431, DPC7330, DPC7331, DPC8131,
DPC8132, DPC6440, DPC6441, DPC7340, DPC7341,
DPC6430, DPC7331, DPC8131, DPC8132, DPC6440
, DPC7341, DPC6430, DPC6431, DPC7330, DPC7331
, DPC8131, DPC8132, DPC6440, DPC6441,
DPC7340, DPC7341

2

Abdeckhaube, Luftfilter
Hood, air filter
Capot protecteur, filtre à air
Cubierta protectora, filtro de aire

Makita[®]

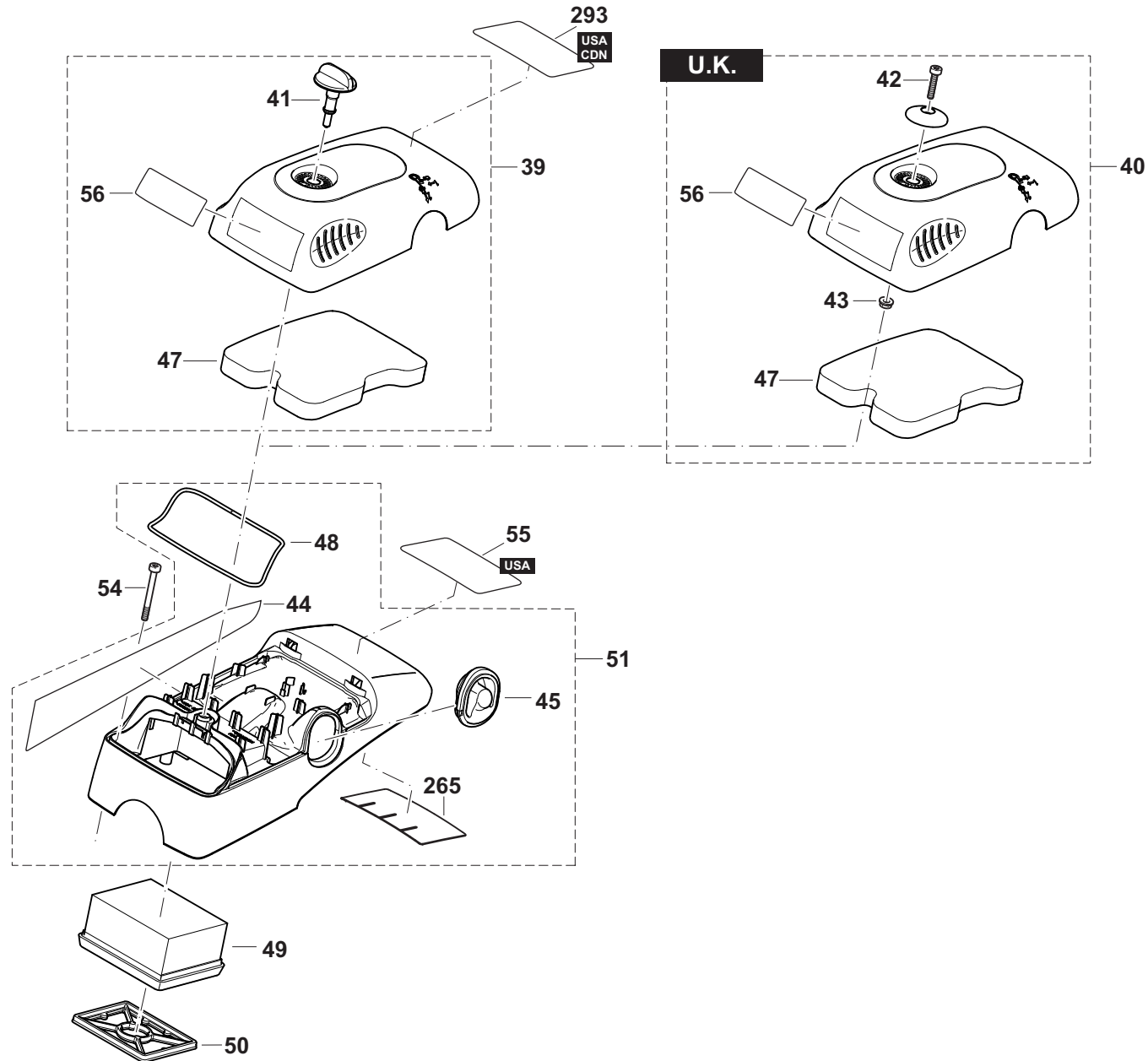

DPC6430, DPC6431, DPC7330, DPC7331, DPC8131, DPC8132, DPC6440, DPC6441, DPC7340, DPC7341, DPC6430, DPC7331, DPC8131, DPC8132, DPC6440, DPC7341, DPC6430, DPC6431, DPC7330, DPC7331, DPC8131, DPC8132, DPC6440, DPC6441, DPC7340, DPC7341

2

Abdeckhaube, Luftfilter
Hood, air filter
Capot protecteur, filtre à air
Cubierta protectora, filtro de aire



Seite / Page	Pos.	DPC6430	DPC6431	DPC7330	DPC7331	DPC8131	DPC8132	DPC6440	DPC6441	DPC7340	DPC7341	DPC6430 (UK)	DPC7331 (UK)	DPC8131 (UK)	DPC8132 (UK)	DPC6440 (UK)	DPC7341 (UK)	DPC6430 (USA)	DPC6431 (USA)	DPC7330 (USA)	DPC7331 (USA)	DPC8131 (USA)	DPC8132 (USA)	DPC6440 (USA)	DPC6441 (USA)	DPC7340 (USA)	DPC7341 (USA)	Teil-Nr. Part No. No. de pièce No. de pieza	Hinweise Notes Renseign. Nota	Bezeichnung	Spezifikation Specification	Descriptio n	Désignation	Denominación
2	50	1	1	1	1	1	1	1	1	1	1	1	1	1	1	1	1	1	1	1	1	1	1	1	1	1	1	395 173 020		INNENFILTER		INNER FILTER	FILTRE INTÉRIEUR	FILTRO DE AIRE INTERIOR
2	51	1	1	1	1	1	1	1	1	1	1	1	1	1	1	1	1	1	1	1	1	1	1	1	1	1	395 118 093	2010 =>	ABDECKHAUB E KPL., SCHWARZ, GEÄTZT	KAT, etchedINC. 44,45,48,265	HOOD CPL.	CAPOT CPL.	TAPA CPL.	
2	51	1	1	1	1	1	1																				395 118 211	RU	ABDECKHAUB E KPL., SCHWARZ, GEÄTZT	black, etched (RU)INC. 44,45,48	HOOD CPL.	CAPOT CPL.	TAPA CPL.	
2	51		1																								395 118 085	VN	ABDECKHAUB E KPL., SCHWARZ, GEÄTZT	black, etchedINC. 44,45,48	HOOD CPL.	CAPOT CPL.	TAPA CPL.	
2	54	4	4	4	4	4	4	4	4	4	4	4	4	4	4	4	4	4	4	4	4	4	4	4	4	4	4	908 605 505		INNENSTERN- SCHRAUBE	M5x50	SCREW	VIS	TORNILLO
2	55																									1	980 115 477	U.S.A.	AUFKLEBER ABDECKHAUB E	DPC7341	LABEL	PLAQUE	CALCOMANIA	
2	56	1	1	1	1	1	1	1	1	1	1	1	1	1	1	1	1	1	1	1	1	1	1	1	1	1	980 114 999		SCHILD	2-TAKT MIX	LABEL	PLAQUE	CALCOMANIA	
2	56	1	1	1	1	1	1																				980 115 617		SCHILD	2-TAKT MIX (RUS)	LABEL	PLAQUE	CALCOMANIA	
2	265							1	1	1	1				1	1											326 118 060		HITZEFOLIE		THERMAL FILM	FILM DE CHALEUR	FOLIO AL CALOR	
2	293																	1	1	1	1	1	1	1	1	1	980 115 602		STARTAUFKLE BER	CDN	LABEL	PLAQUE	CALCOMANIA	
2	293																	1	1	1	1	1	1	1	1	1	980 115 607		STARTAUFKLE BER	USA	LABEL	PLAQUE	CALCOMANIA	

DPC6430, DPC6431, DPC7330, DPC7331, DPC8131,
 DPC8132, DPC6440, DPC6441, DPC7340, DPC7341,
 DPC6430, DPC7331, DPC8131, DPC8132, DPC6440
 , DPC7341 , DPC6430 , DPC6431 , DPC7330 , DPC7331
 , DPC8131 , DPC8132 , DPC6440 , DPC6441 ,
 DPC7340 , DPC7341

3

Schalldämpfer, Ansaugkrümmer
 Muffler, connecting muff
 Pot d' échappement, manchon de jonction
 Silencioso, manguito de conexión

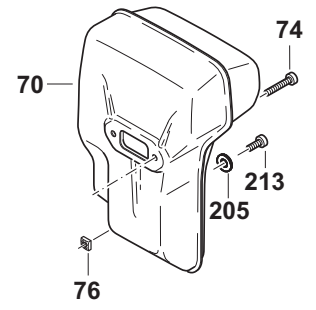
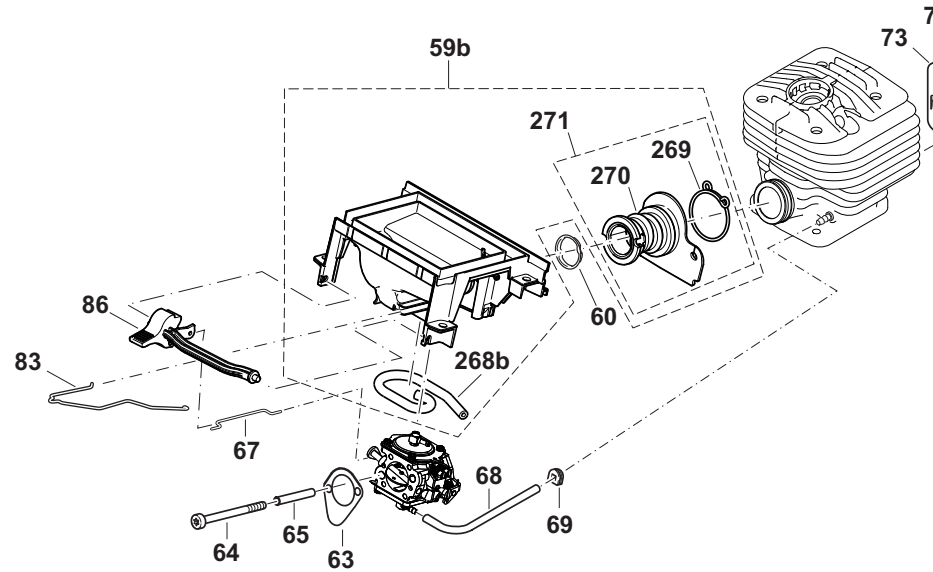
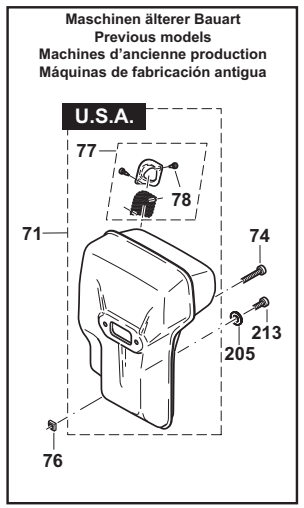
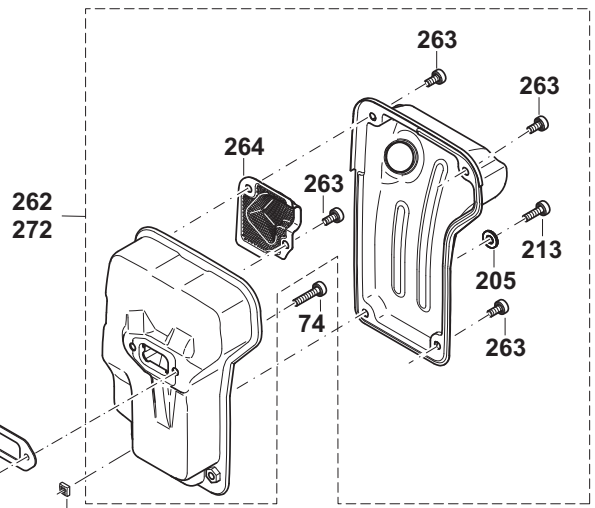
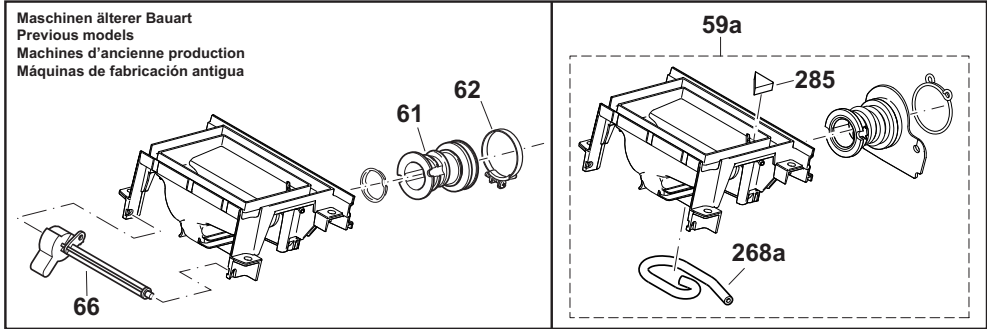

DPC6430, DPC6431, DPC7330, DPC7331, DPC8131, DPC8132, DPC6440, DPC6441, DPC7340, DPC7341, DPC6430, DPC7331, DPC8131, DPC8132, DPC6440, DPC7341, DPC6430, DPC6431, DPC7330, DPC7331, DPC8131, DPC8132, DPC6440, DPC6441, DPC7340, DPC7341

3

Schalldämpfer, Ansaugkrümmer
Muffler, connecting muff
Pot d' échappement, manchon de jonction
Silencioso, manguito de conexión



Seite / Page	Pos.	DPC6430	DPC6431	DPC7330	DPC7331	DPC8131	DPC8132	DPC6440	DPC6441	DPC7340	DPC7341	DPC6430 (UK)	DPC7331 (UK)	DPC8131 (UK)	DPC8132 (UK)	DPC6440 (UK)	DPC7341 (UK)	DPC6430 (USA)	DPC6431 (USA)	DPC7330 (USA)	DPC7331 (USA)	DPC8131 (USA)	DPC8132 (USA)	DPC6440 (USA)	DPC6441 (USA)	DPC7340 (USA)	DPC7341 (USA)	Teil-Nr. Part No. No. de pièce No. de pieza	Hinweise Notes Renseign. Nota	Bezeichnung	Spezifikation Specification	Description	Désignation	Denominación	
3	59a	1	1	1	1	1	1	1	1	1	1	1	1	1	1	1	1	1	1	1	1	1	1	1	1	1	1	1	395 171 071		ANSAUGKRÜMMER KPL.	INC. 285,268a	CONNECTING MUFF CPL.	MANCHON DE JONCTION CPL.	MANGUITO DE CONEXIÓN CPL.
3	59b	1	1	1	1	1	1	1	1	1	1	1	1	1	1	1	1	1	1	1	1	1	1	1	1	1	1	395 171 072		ANSAUGKRÜMMER KPL.	INC. 268b,271	CONNECTING MUFF CPL.	MANCHON DE JONCTION CPL.	MANGUITO DE CONEXIÓN CPL.	
3	60	1	1	1	1	1	1	1	1	1	1	1	1	1	1	1	1	1	1	1	1	1	1	1	1	1	1	024 131 032		EINSATZ FÜR ANSAUGSCHLAUCH		INSERT FOR SUCTION HOSE	PIÈCE P. TUYAU	SUPLEMENTO P. TUBO	
3	61	1	1	1	1	1	1	1	1	1	1	1	1	1	1	1	1	1	1	1	1	1	1	1	1	1	1	394 131 101		ANSAUGSCHLAUCH		SUCTION LINE	CONDUITE D'ASPIRATION	CONDUCTO DE ASPIRACIÓN	
3	62	1	1	1	1	1	1	1	1	1	1	1	1	1	1	1	1	1	1	1	1	1	1	1	1	1	1	965 603 050		SCHLAUCHSCHELLE		HOSE CLIP	COLLIER DE SERRAGE	ABRAZADERA	
3	63	1	1	1	1	1	1	1	1	1	1	1	1	1	1	1	1	1	1	1	1	1	1	1	1	1	1	965 518 120		DICHTUNG		GASKET	JOINT	JUNTA	
3	64	2	2	2	2	2	2	2	2	2	2	2	2	2	2	2	2	2	2	2	2	2	2	2	2	2	2	908 204 555		INNENSTERN-SCHRAUBE	M4x55	SCREW	VIS	TORNILLO	
3	65	m	m	m	m	m	m	m	m	m	m	m	m	m	m	m	m	m	m	m	m	m	m	m	m	m	m	970 502 050		SCHLAUCH	37mm; 1 1/2"	TUBE	GAINE	TUBO	
3	66	1	1	1	1	1	1	1	1	1	1	1	1	1	1	1	1	1	1	1	1	1	1	1	1	1	1	394 150 030		CHOKEWELLE		CHOKE SHAFT	AXE	EJE	
3	67	1	1	1	1	1	1	1	1	1	1	1	1	1	1	1	1	1	1	1	1	1	1	1	1	1	1	394 150 042		CHOKESTANGE		CHOKE SHAFT	LEVIER	PALANCE	
3	68	m	m	m	m	m	m	m	m	m	m	m	m	m	m	m	m	m	m	m	m	m	m	m	m	m	m	965 452 382		SCHLAUCH	120mm; 4 3/4"	TUBE	GAINE	TUBO	
3	69	1	1	1	1	1	1	1	1	1	1	1	1	1	1	1	1	1	1	1	1	1	1	1	1	1	1	965 401 016		GUMMITÜLLE		RUBBER BUSH	GAINE CAOUTCHOU C	BOQUILLA DE CAUCHO	
3	70	1	1	1	1	1	1					1	1	1	1													394 174 401		SCHALLDÄMPFER KPL.		MUFFLER	POT D'ÉCHAPPEMENT	SILENCIADOR	
3	71																	1	1	1	1	1						394 174 152	U.S.A.	SCHALLDÄMPFER	USAINC. 77	MUFFLER	POT D'ÉCHAPPEMENT	SILENCIADOR	
3	72	1	1	1	1	1	1	1	1	1	1	1	1	1	1	1	1	1	1	1	1	1	1	1	1	1	1	395 174 120		DICHTUNG		GASKET	JOINT	JUNTA	
3	73	1	1	1	1	1	1	1	1	1	1	1	1	1	1	1	1	1	1	1	1	1	1	1	1	1	1	395 174 110		ABSCHIRMBLECH		COOLING PLATE	TÔLE DE PROTECTION	CHAPA DEFLECTORA	
3	74	2	2	2	2	2	2	2	2	2	2	2	2	2	2	2	2	2	2	2	2	2	2	2	2	2	2	908 405 205		SCHRAUBE INNEN6RD ZK	M5x20	H.L. SOCKET HEAD BOLT	VIS	TORNILLO	
3	76	1	1	1	1	1	1					1	1	1	1			1	1	1	1	1						038 111 060		4KT-MUTTER	M5, SW10	SQUARE NUT	ECROU CARRÉ	TUERCA CUADR.	
3	77																	1	1	1	1	1						394 174 142	U.S.A.	FUNKENSCHUTZSIEB	INC. 78	SPARK ARRESTER SCREEN	TAMIS	TAMIZ	
3	78																	2	2	2	2	2						915 035 120	U.S.A.	SCHRAUBE		SCREW	VIS	TORNILLO	

DPC6430, DPC6431, DPC7330, DPC7331, DPC8131,
 DPC8132, DPC6440, DPC6441, DPC7340, DPC7341,
 DPC6430, DPC7331, DPC8131, DPC8132, DPC6440
 , DPC7341 , DPC6430 , DPC6431 , DPC7330 , DPC7331
 , DPC8131 , DPC8132 , DPC6440 , DPC6441 ,
 DPC7340 , DPC7341

3

Schalldämpfer, Ansaugkrümmer
 Muffler, connecting muff
 Pot d' échappement, manchon de jonction
 Silencioso, manguito de conexión

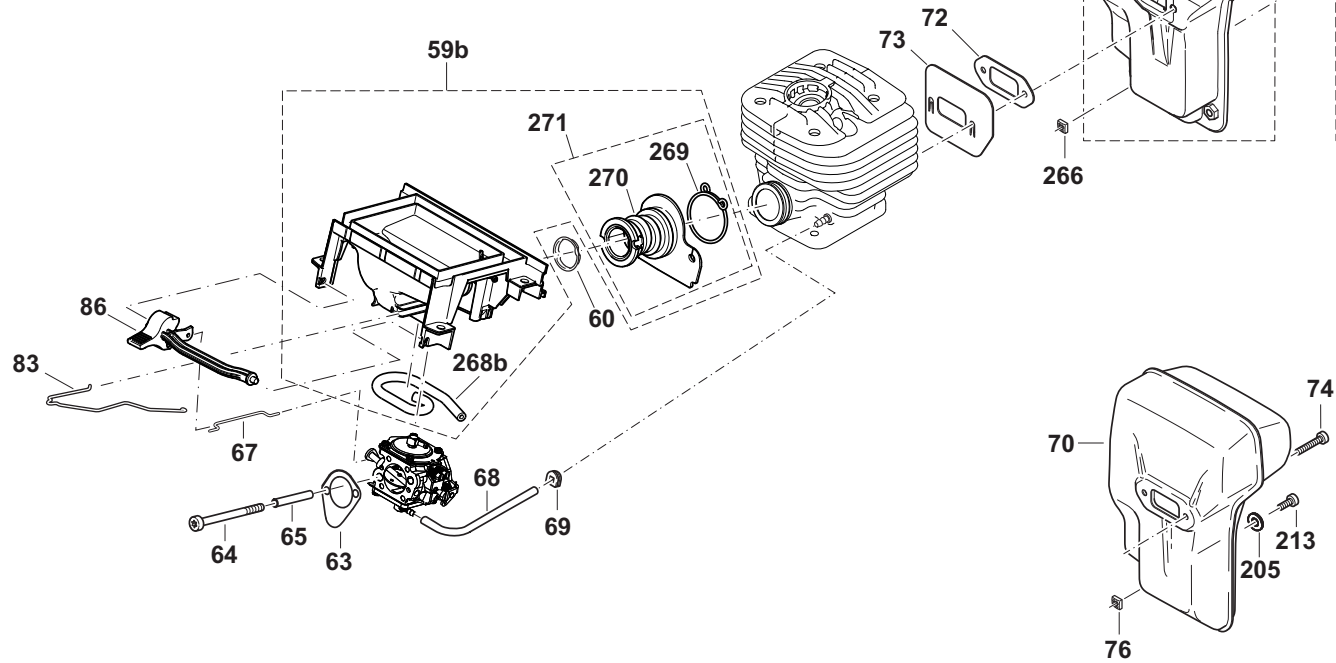
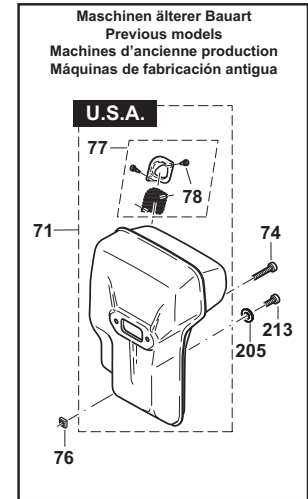
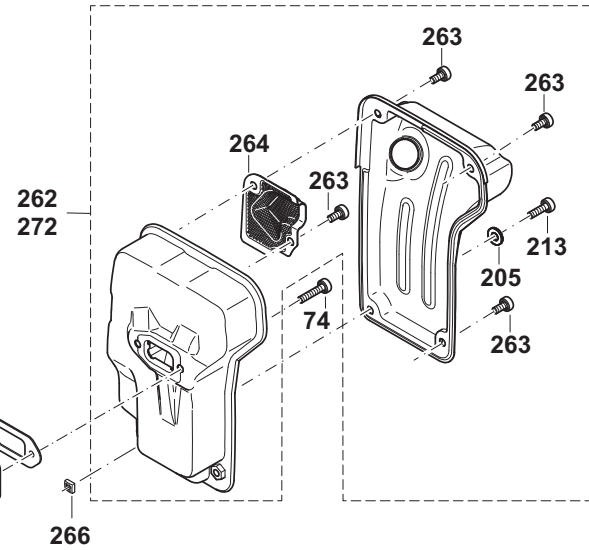
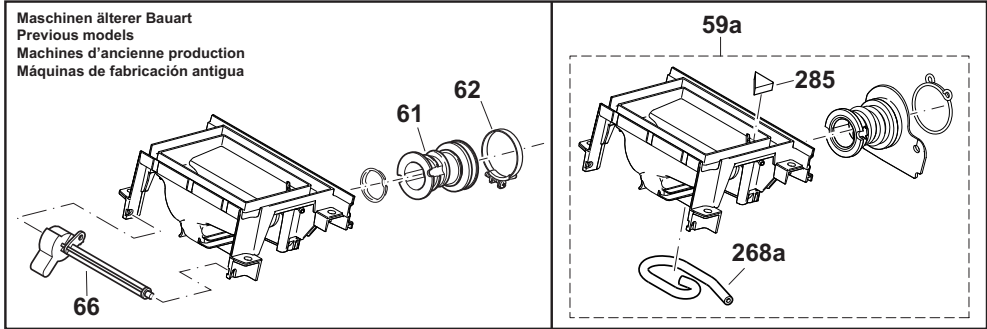

DPC6430, DPC6431, DPC7330, DPC7331, DPC8131, DPC8132, DPC6440, DPC6441, DPC7340, DPC7341, DPC6430, DPC7331, DPC8131, DPC8132, DPC6440, DPC7341, DPC6430, DPC6431, DPC7330, DPC7331, DPC8131, DPC8132, DPC6440, DPC6441, DPC7340, DPC7341

3

Schalldämpfer, Ansaugkrümmer
Muffler, connecting muff
Pot d' échappement, manchon de jonction
Silencioso, manguito de conexión



Seite / Page	Pos.	DPC6430	DPC6431	DPC7330	DPC7331	DPC8131	DPC8132	DPC6440	DPC6441	DPC7340	DPC7341	DPC6430 (UK)	DPC7331 (UK)	DPC8131 (UK)	DPC8132 (UK)	DPC6440 (UK)	DPC7341 (UK)	DPC6430 (USA)	DPC6431 (USA)	DPC7330 (USA)	DPC7331 (USA)	DPC8131 (USA)	DPC8132 (USA)	DPC6440 (USA)	DPC6441 (USA)	DPC7340 (USA)	DPC7341 (USA)	Teil-Nr. Part No. No. de pièce No. de pieza	Hinweise Notes Renseign. Nota	Bezeichnung	Spezifikation Specification	Description	Désignation	Denominación
3	83	1	1	1	1	1	1	1	1	1	1	1	1	1	1	1	1	1	1	1	1	1	1	1	1	1	1	395 117 011		GASGESTÄNGE		THROTTLE LINKAGE	TRINGLE D' ACCÉLÉRATION	VARILLA ACELERADOR
3	86	1	1	1	1	1	1	1	1	1	1	1	1	1	1	1	1	1	1	1	1	1	1	1	1	1	957 395 001		REP.-SATZ CHOKEWELLE / KONTAKTFEDER		KIT CHOKE SHAFT / CONTACT SPRING	JEU AXE CLAPET D'AIR / RESSORT DE CONTACT	JUEGO EJE VÁLVULA AIRE / RESORTE DE CONTACTO	
3	205	1	1	1	1	1	1	1	1	1	1	1	1	1	1	1	1	1	1	1	1	1	1	1	1	1	928 405 000		SPANNSCHEIBE		DISC	DISQUE	ARANDELA	
3	213	1	1	1	1	1	1	1	1	1	1	1	1	1	1	1	1	1	1	1	1	1	1	1	1	1	908 005 125		INNENSTERN-SCHRAUBE	M5x12	SCREW	VIS	TORNILLO	
3	262							1	1	1	1					1	1										394 174 550		SCHALLDÄMPFER	KATINC. 205,213,263,264	MUFFLER	POT D' ÉCHAPPEMENT	SILENCIADOR	
3	263							4	4	4	4					4	4										908 005 095		SCHRAUBE	M5x9	SCREW	VIS	TORNILLO	
3	264							1	1	1	1					1	1										394 174 340		FUNKENSCHUTZSIEB		SPARK ARRESTER SCREEN	TAMIS	TAMIZ	
3	266							1	1	1	1					1	1										038 111 060		4KT-MUTTER	M5, SW10	SQUARE NUT	ECROU CARRÉ	TUERCA CUADR.	
3	268a	1	1	1	1	1	1	1	1	1	1	1	1	1	1	1	1	1	1	1	1	1	1	1	1	1	395 171 022		KOMPENSATIONSSCHLAUCH	l=155mm, black	TUBE	GAINE	TUBO	
3	268b	1	1	1	1	1	1	1	1	1	1	1	1	1	1	1	1	1	1	1	1	1	1	1	1	1	395 171 025		KOMPENSATIONSSCHLAUCH	l=138mm, red/black	TUBE	GAINE	TUBO	
3	269	1	1	1	1	1	1	1	1	1	1	1	1	1	1	1	1	1	1	1	1	1	1	1	1	1	038 131 070		FEDERSCHLE		HOSE CLIP	COLLIER DE SERRAGE	ABRAZADERA	
3	270	1	1	1	1	1	1	1	1	1	1	1	1	1	1	1	1	1	1	1	1	1	1	1	1	1	394 131 200		ANSAUGSCHLAUCH		SUCTION HOSE	TUYAU D' ASPIRATION	TUBO DE ASPIRACIÓN	
3	271	1	1	1	1	1	1	1	1	1	1	1	1	1	1	1	1	1	1	1	1	1	1	1	1	1	394 131 210		ANSAUGSCHLAUCH	SETINC. 269,270	SUCTION HOSE	TUYAU D' ASPIRATION	TUBO DE ASPIRACIÓN	
3	272															1	1	1	1	1	1						394 174 560		SCHALLDÄMPFER	USA, w/o KATINC. 205,213,263,264	EXHAUST MUFFLER	POT D' ÉCHAPPEMENT	SILENCIADOR	
3	285	1	1	1	1	1	1	1	1	1	1	1	1	1	1	1	1	1	1	1	1	1	1	1	1	1	395 173 030		SCHAUMSTOFFEINSATZ		FOAM-INSERT	MOUSSE DE NYLON	ESPUMA DE PLÁST.	

DPC6430, DPC6431, DPC7330, DPC7331, DPC8131,
 DPC8132, DPC6440, DPC6441, DPC7340, DPC7341,
 DPC6430, DPC7331, DPC8131, DPC8132, DPC6440
 , DPC7341 , DPC6430 , DPC6431 , DPC7330 , DPC7331
 , DPC8131 , DPC8132 , DPC6440 , DPC6441 ,
 DPC7340 , DPC7341

4

Vergaser
 Carbuřetor
 Carburateur
 Carburador

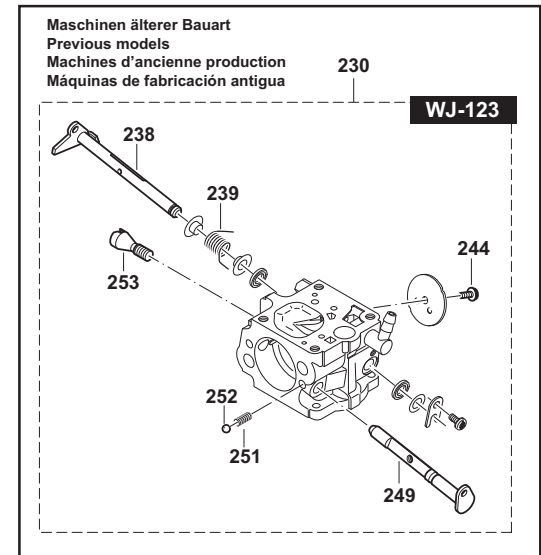
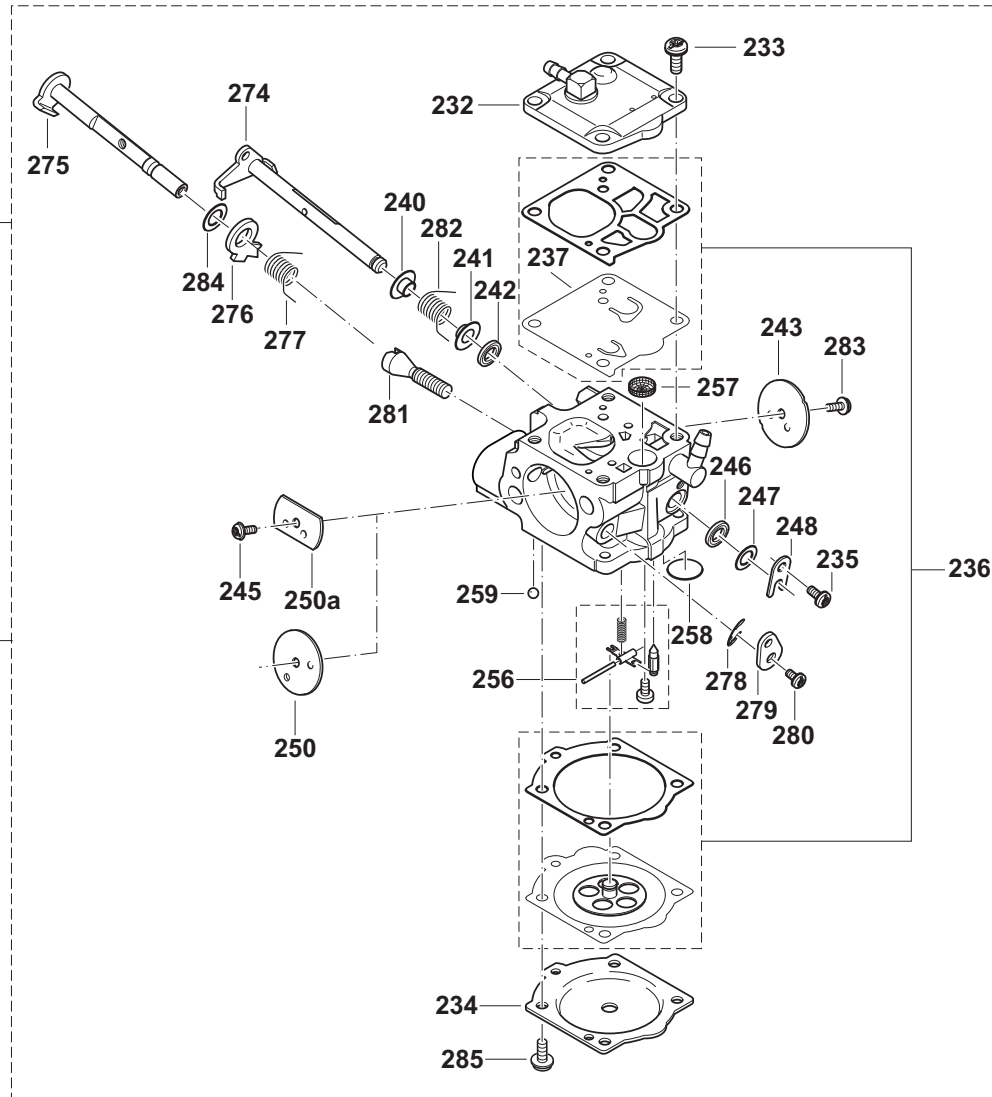
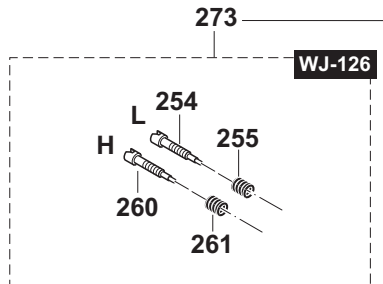
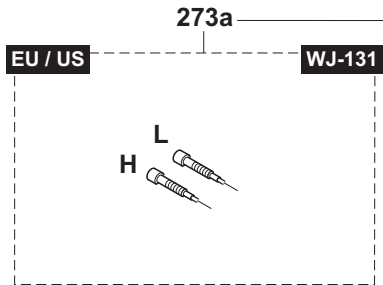

DPC6430, DPC6431, DPC7330, DPC7331, DPC8131, DPC8132, DPC6440, DPC6441, DPC7340, DPC7341, DPC6430, DPC7331, DPC8131, DPC8132, DPC6440, DPC7341, DPC6430, DPC6431, DPC7330, DPC7331, DPC8131, DPC8132, DPC6440, DPC6441, DPC7340, DPC7341

4

Vergaser
Carburetor
Carburateur
Carburador



Seite / Page	Pos.	DPC6430	DPC6431	DPC7330	DPC7331	DPC8131	DPC8132	DPC6440	DPC6441	DPC7340	DPC7341	DPC6430 (UK)	DPC7331 (UK)	DPC8131 (UK)	DPC8132 (UK)	DPC6440 (UK)	DPC7341 (UK)	DPC6430 (USA)	DPC6431 (USA)	DPC7330 (USA)	DPC7331 (USA)	DPC8131 (USA)	DPC8132 (USA)	DPC6440 (USA)	DPC6441 (USA)	DPC7340 (USA)	DPC7341 (USA)	Teil-Nr. Part No. No. de pièce No. de pieza	Hinweise Notes Renseign. Nota	Bezeichnung	Spezifikation Specification	Description	Désignation	Denominación
4	230	1	1	1	1	1	1	1	1	1	1	1	1	1	1	1	1	1	1	1	1	1	1	1	1	1	1	395 151 050		VERGASER	WJ-123INC. 232-236,238-250,251-261, 274-285	CARBURETOR	CARBURATEUR	CARBURADOR
4	232	1	1	1	1	1	1	1	1	1	1	1	1	1	1	1	1	1	1	1	1	1	1	1	1	1	394 151 160		PUMPENDECKEL KPL.		PUMP COVER CPL.	COUVERCLE DE POMPE CPL.	TAPA DE BOMBA CPL.	
4	233	4	4	4	4	4	4	4	4	4	4	4	4	4	4	4	4	4	4	4	4	4	4	4	4	4	144 150 170		SCHRAUBE		SCREW	VIS	TORNILLO	
4	234	1	1	1	1	1	1	1	1	1	1	1	1	1	1	1	1	1	1	1	1	1	1	1	1	1	395 151 120		MEMBRANDECKEL		DIAPHRAGM COVER	COUVERCLE DE MEMBRANE	TAPA DE MEMBRANA	
4	235	1	1	1	1	1	1	1	1	1	1	1	1	1	1	1	1	1	1	1	1	1	1	1	1	1	378 151 220		SCHRAUBE		SCREW	VIS	TORNILLO	
4	236	1	1	1	1	1	1	1	1	1	1	1	1	1	1	1	1	1	1	1	1	1	1	1	1	1	957 151 180		MEMBRANSATZ	INC. 237	SET DIAPHRAGM / GASKETS	JEU DE MEMBRANES / JOINTS	JUEGO MEMBRANAS / JUNTAS	
4	237	1	1	1	1	1	1	1	1	1	1	1	1	1	1	1	1	1	1	1	1	1	1	1	1	1	394 151 150		PUMPENMEMBRAN, GUMMI		PUMP DIAPHRAGM	MEMBR. DE POMPE	MEMBR. D. LA BOMBA	
4	238	1	1	1	1	1	1	1	1	1	1	1	1	1	1	1	1	1	1	1	1	1	1	1	1	1	394 151 300		DROSSELKLAFFPENWELLE		THROTTLE SHAFT	AXE CLAPET D'ÉTRANGLEMENT	EJE VÁLVULA REGULADOR	
4	239	1	1	1	1	1	1	1	1	1	1	1	1	1	1	1	1	1	1	1	1	1	1	1	1	1	394 151 310		DREHFEDER		SPRING	RESSORT	RESORTE	
4	240	1	1	1	1	1	1	1	1	1	1	1	1	1	1	1	1	1	1	1	1	1	1	1	1	1	394 151 315		BUCHSE		BUSHING	DOUILLE	CASQUILLO	
4	241	1	1	1	1	1	1	1	1	1	1	1	1	1	1	1	1	1	1	1	1	1	1	1	1	1	394 151 315		BUCHSE		BUSHING	DOUILLE	CASQUILLO	
4	242	1	1	1	1	1	1	1	1	1	1	1	1	1	1	1	1	1	1	1	1	1	1	1	1	1	394 151 330		DICHTRING		PACKING RING	BAGUE-JOINT	ANILLO DE GUARNICIÓN	
4	243	1	1	1	1	1	1	1	1	1	1	1	1	1	1	1	1	1	1	1	1	1	1	1	1	1	394 151 320		DROSSELKLAFFPE		THROTTLE SHUTTER	CLAPET D'ÉTRANGLEMENT	VÁLVULA REGULADORA	
4	244	1	1	1	1	1	1	1	1	1	1	1	1	1	1	1	1	1	1	1	1	1	1	1	1	1	394 151 650		SCHRAUBE		SCREW	VIS	TORNILLO	
4	245	1	1	1	1	1	1	1	1	1	1	1	1	1	1	1	1	1	1	1	1	1	1	1	1	1	394 151 660		SCHRAUBE		SCREW	VIS	TORNILLO	
4	246	1	1	1	1	1	1	1	1	1	1	1	1	1	1	1	1	1	1	1	1	1	1	1	1	1	394 151 330		DICHTRING		PACKING RING	BAGUE-JOINT	ANILLO DE GUARNICIÓN	
4	247	1	1	1	1	1	1	1	1	1	1	1	1	1	1	1	1	1	1	1	1	1	1	1	1	1	394 151 400		SCHEIBE		DISC	DISQUE	DISCO	
4	248	1	1	1	1	1	1	1	1	1	1	1	1	1	1	1	1	1	1	1	1	1	1	1	1	1	108 151 350		WELLENSICHERUNG		SHAFT CLIP	TÔLE DE SÉCURITÉ	PIEZA SEGURIDAD ÁRBOL	
4	249	1	1	1	1	1	1	1	1	1	1	1	1	1	1	1	1	1	1	1	1	1	1	1	1	1	394 151 250		CHOKEWELLE		SHAFT	AXE	EJE	
4	250	1	1	1	1	1	1	1	1	1	1	1	1	1	1	1	1	1	1	1	1	1	1	1	1	1	395 151 260	=> 2013-12	CHOKEKLAPPE		CHOKE SHUTTER	CLAPET D'AIR	VÁLVULA DE AIRE	
4	250a	1	1	1	1	1	1	1	1	1	1	1	1	1	1	1	1	1	1	1	1	1	1	1	1	1	395 151 265	2014-01 =>	CHOKEKLAPPE		CHOKE SHUTTER	CLAPET D'AIR	VÁLVULA DE AIRE	
4	251	1	1	1	1	1	1	1	1	1	1	1	1	1	1	1	1	1	1	1	1	1	1	1	1	1	118 151 160		ARRETIERFEDER		LOCKING SPRING	RESSORT D'ARRÊT	RESORTE DE TOPE	

DPC6430, DPC6431, DPC7330, DPC7331, DPC8131,
 DPC8132, DPC6440, DPC6441, DPC7340, DPC7341,
 DPC6430, DPC7331, DPC8131, DPC8132, DPC6440
 , DPC7341 , DPC6430 , DPC6431 , DPC7330 , DPC7331
 , DPC8131 , DPC8132 , DPC6440 , DPC6441 ,
 DPC7340 , DPC7341

4

Vergaser
 Carbuřetor
 Carburateur
 Carburador

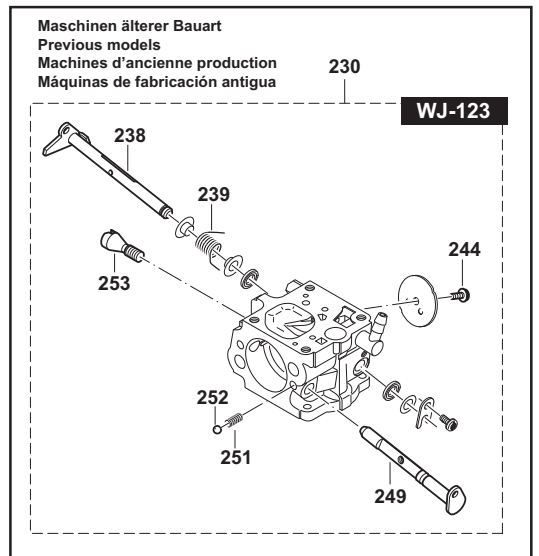
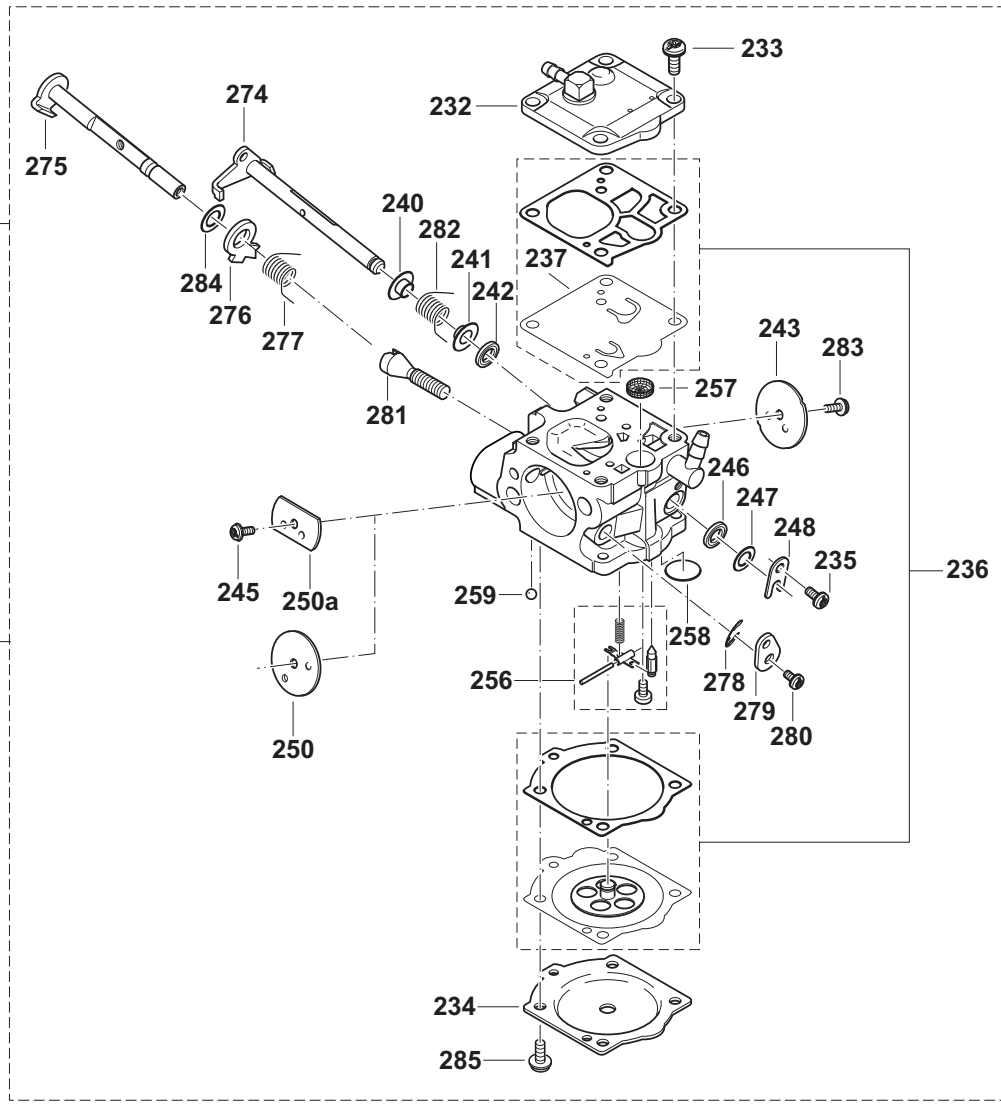
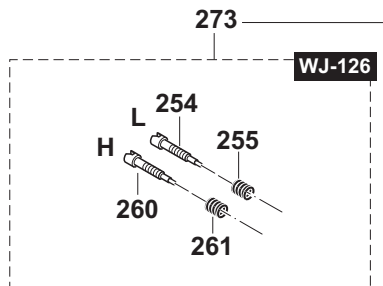
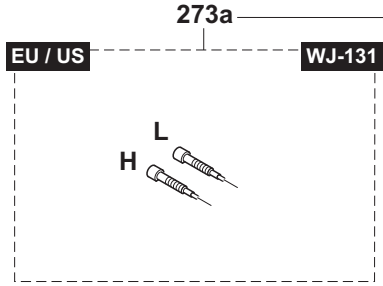

DPC6430, DPC6431, DPC7330, DPC7331, DPC8131, DPC8132, DPC6440, DPC6441, DPC7340, DPC7341, DPC6430, DPC7331, DPC8131, DPC8132, DPC6440, DPC7341, DPC6430, DPC6431, DPC7330, DPC7331, DPC8131, DPC8132, DPC6440, DPC6441, DPC7340, DPC7341

4

Vergaser
Carburetor
Carburateur
Carburador



Seite / Page	Pos.	DPC6430	DPC6431	DPC7330	DPC7331	DPC8131	DPC8132	DPC6440	DPC6441	DPC7340	DPC7341	DPC6430 (UK)	DPC7331 (UK)	DPC8131 (UK)	DPC8132 (UK)	DPC6440 (UK)	DPC7341 (UK)	DPC6430 (USA)	DPC6431 (USA)	DPC7330 (USA)	DPC7331 (USA)	DPC8131 (USA)	DPC8132 (USA)	DPC6440 (USA)	DPC6441 (USA)	DPC7340 (USA)	DPC7341 (USA)	Teil-Nr. Part No. No. de pièce No. de pieza	Hinweise Notes Renseign. Nota	Bezeichnung	Spezifikation Specification	Description	Désignation	Denominación
4	252	1	1	1	1	1	1	1	1	1	1	1	1	1	1	1	1	1	1	1	1	1	1	1	1	1	1	118 151 170		ARRETIERKUGEL		LOCKING BALL	BILLE D'ARRÊT	BOLA DE TOPE
4	253	1	1	1	1	1	1	1	1	1	1	1	1	1	1	1	1	1	1	1	1	1	1	1	1	1	394 151 570		LEERLAUF-ANSCHLAGSCHRÄUBE	S	IDLE STOP SCREW	VIS DE BUTÉE DE RALENTI	TORNILLO DE TOPE	
4	254	1	1	1	1	1	1	1	1	1	1	1	1	1	1	1	1										394 151 470		LEERLAUF-STELLSCHRAUBE	L	IDLE ADJUSTMENT SCREW	VIS DE RÉGL. DE RALENTI	TORNILLO REGULADOR	
4	255	1	1	1	1	1	1	1	1	1	1	1	1	1	1	1											021 151 480		FEDER	L	SPRING	RESSORT	RESORTE	
4	256	1	1	1	1	1	1	1	1	1	1	1	1	1	1	1	1	1	1	1	1	1	1	1	1	1	957 151 191		SATZ STEUERTEILE		CONTROL PARTS	PIÈCES DE COMM.	PIEZAS DE MANDO	
4	257	1	1	1	1	1	1	1	1	1	1	1	1	1	1	1	1	1	1	1	1	1	1	1	1	1	021 151 180		SIEB		SCREEN	TAMIS	TAMIZ	
4	258	1	1	1	1	1	1	1	1	1	1	1	1	1	1	1	1	1	1	1	1	1	1	1	1	1	394 151 040		VERSCHLUßSCHEIBE		COVER DISC	DISQUE DE FERMETURE	DISCO DE SIERRE	
4	259	1	1	1	1	1	1	1	1	1	1	1	1	1	1	1	1	1	1	1	1	1	1	1	1	1	394 151 510		SICHERUNGSEINSATZ		LOCKING BALL	BILLE D'ARRÊT	BOLA DE TOPE	
4	260	1	1	1	1	1	1	1	1	1	1	1	1	1	1	1											001 151 450		VOLLGAS-STELLSCHRAUBE	H	MAIN ADJUSTMENT SCREW	VIS DE RÉGL. PLEIN GAZ	TORNILLO REGULADOR	
4	261	1	1	1	1	1	1	1	1	1	1	1	1	1	1	1											021 151 480		FEDER	L	SPRING	RESSORT	RESORTE	
4	273	1	1	1	1	1	1	1	1	1	1																395 151 015		VERGASER	WJ-126c (non regulated market)INC. 232-236,240-243,245-248,250a,254-261,274-285	CARBURETOR	CARBURATEUR	CARBURADOR	
4	273a	1	1	1	1	1	1	1	1	1	1																395 151 025		VERGASER	D, WJ-131A (EU, USA - regulated market)INC. 232-236,240-243,245-248,250a,256-259,274-285	CARBURETOR	CARBURATEUR	CARBURADOR	
4	274	1	1	1	1	1	1	1	1	1	1	1	1	1	1	1	1	1	1	1	1	1	1	1	1	1	395 151 130		DROSSELKLAPPENWELLE		THROTTLE SHAFT	AXE CLAPET D'ÉTRANG.	EJE VÁLVULA REG.	
4	275	1	1	1	1	1	1	1	1	1	1	1	1	1	1	1	1	1	1	1	1	1	1	1	1	1	395 151 170		CHOKEWELLE		CHOKE SHAFT	AXE CLAPET D'AIR	EJE VÁLVULA AIRE	
4	276	1	1	1	1	1	1	1	1	1	1	1	1	1	1	1	1	1	1	1	1	1	1	1	1	1	395 151 110		HALBGASHEBEL		FAST IDLE LEVER	LEVIER	PALANCA	
4	277	1	1	1	1	1	1	1	1	1	1	1	1	1	1	1	1	1	1	1	1	1	1	1	1	1	395 151 190		DREHFEDER		TORSION SPRING	RESSORT DE TENSION	RESORTE DE TORSIÓN	
4	278	1	1	1	1	1	1	1	1	1	1	1	1	1	1	1	1	1	1	1	1	1	1	1	1	1	119 151 350		WELLENSICHERUNG		SHAFT CLIP	TÔLE DE SÉCURITÉ	PIEZA SEGURIDAD ÁRBOL	
4	279	1	1	1	1	1	1	1	1	1	1	1	1	1	1	1	1	1	1	1	1	1	1	1	1	1	395 151 180		CHOKEHEBEL		CHOKE LEVER	LEVIER DE STARTER	PALANCA ESTRANGULADOR DE AIRE	

DPC6430, DPC6431, DPC7330, DPC7331, DPC8131,
 DPC8132, DPC6440, DPC6441, DPC7340, DPC7341,
 DPC6430, DPC7331, DPC8131, DPC8132, DPC6440
 , DPC7341 , DPC6430 , DPC6431 , DPC7330 , DPC7331
 , DPC8131 , DPC8132 , DPC6440 , DPC6441 ,
 DPC7340 , DPC7341

4

Vergaser
 Carburator
 Carburateur
 Carburador

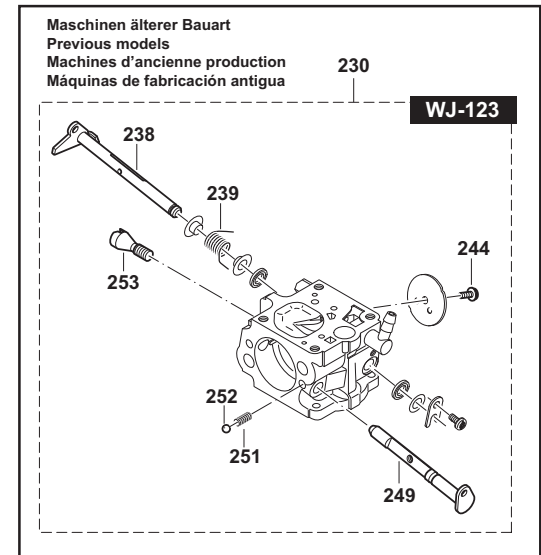
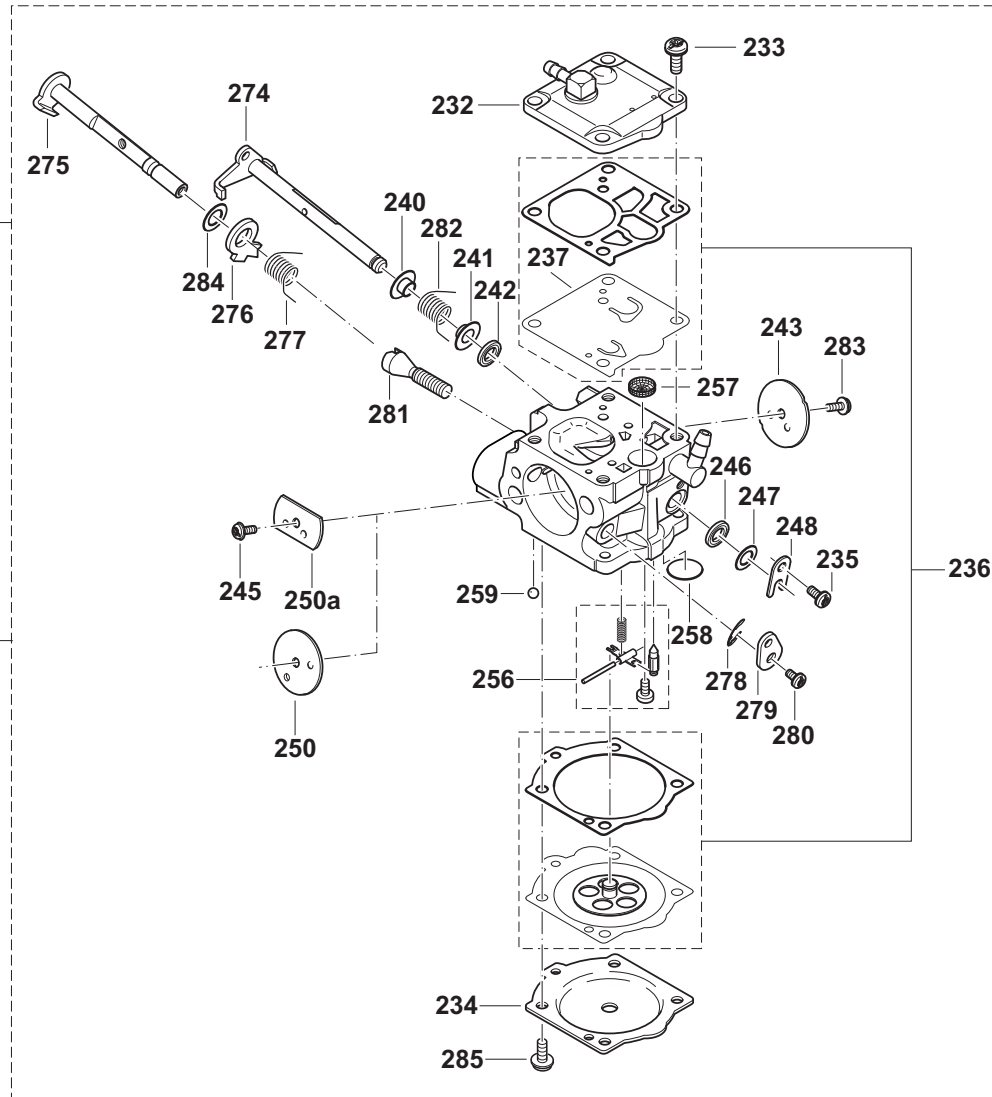
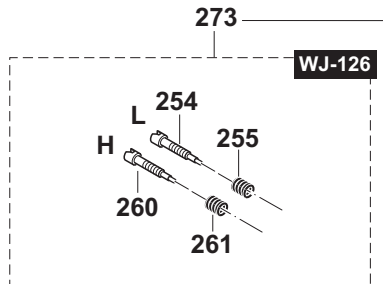
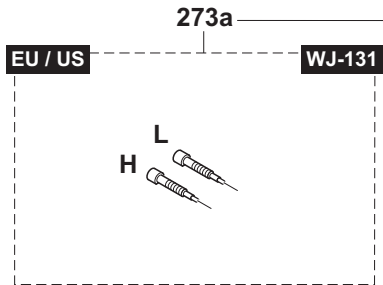

DPC6430, DPC6431, DPC7330, DPC7331, DPC8131,
 DPC8132, DPC6440, DPC6441, DPC7340, DPC7341,
 DPC6430, DPC7331, DPC8131, DPC8132, DPC6440
 , DPC7341 , DPC6430 , DPC6431 , DPC7330 , DPC7331
 , DPC8131 , DPC8132 , DPC6440 , DPC6441 ,
 DPC7340 , DPC7341

4

Vergaser
 Carburator
 Carburateur
 Carburador



Seite / Page	Pos.	DPC6430	DPC6431	DPC7330	DPC7331	DPC8131	DPC8132	DPC6440	DPC6441	DPC7340	DPC7341	DPC6430 (UK)	DPC7331 (UK)	DPC8131 (UK)	DPC8132 (UK)	DPC6440 (UK)	DPC7341 (UK)	DPC6430 (USA)	DPC6431 (USA)	DPC7330 (USA)	DPC7331 (USA)	DPC8131 (USA)	DPC8132 (USA)	DPC6440 (USA)	DPC6441 (USA)	DPC7340 (USA)	DPC7341 (USA)	Teil-Nr. Part No. No. de pièce No. de pieza	Hinweise Notes Renseign. Nota	Bezeichnung	Spezifikation Specification	Description	Désignation	Denominación
4	280	1	1	1	1	1	1	1	1	1	1	1	1	1	1	1	1	1	1	1	1	1	1	1	1	1	1	394 151 660		SCHRAUBE		SCREW	VIS	TORNILLO
4	281	1	1	1	1	1	1	1	1	1	1	1	1	1	1	1	1	1	1	1	1	1	1	1	1	1	395 151 140		LEERLAUF-AN SCHLAGSCHR AUBE	S	IDLE STOP SCREW	VIS DE BUTÉE DE RALENTI	TORNILLO DE TOPE	
4	282	1	1	1	1	1	1	1	1	1	1	1	1	1	1	1	1	1	1	1	1	1	1	1	1	1	395 151 150		DREHFEDER		TORSION SPRING	RESSORT DE TENSION	RESORTE DE TORSIÓN	
4	283	1	1	1	1	1	1	1	1	1	1	1	1	1	1	1	1	1	1	1	1	1	1	1	1	1	394 151 660		SCHRAUBE		SCREW	VIS	TORNILLO	
4	284	1	1	1	1	1	1	1	1	1	1	1	1	1	1	1	1	1	1	1	1	1	1	1	1	1	170 151 290		SCHEIBE		WASHER	RONDELLE	ARANDELA	
4	285	4	4	4	4	4	4	4	4	4	4	4	4	4	4	4	4	4	4	4	4	4	4	4	4	4	378 151 220		SCHRAUBE		SCREW	VIS	TORNILLO	

DPC6430, DPC6431, DPC7330, DPC7331, DPC8131,
 DPC8132, DPC6440, DPC6441, DPC7340, DPC7341,
 DPC6430, DPC7331, DPC8131, DPC8132, DPC6440
 , DPC7341 , DPC6430 , DPC6431 , DPC7330 , DPC7331
 , DPC8131 , DPC8132 , DPC6440 , DPC6441 ,
 DPC7340 , DPC7341

5

Anwerfvorrichtung, Magnetzünder
 Starter Assy., ignition Assy.
 Dispositif de démarrage, volant magnétique
 Dispositivo arranque, volante magnético

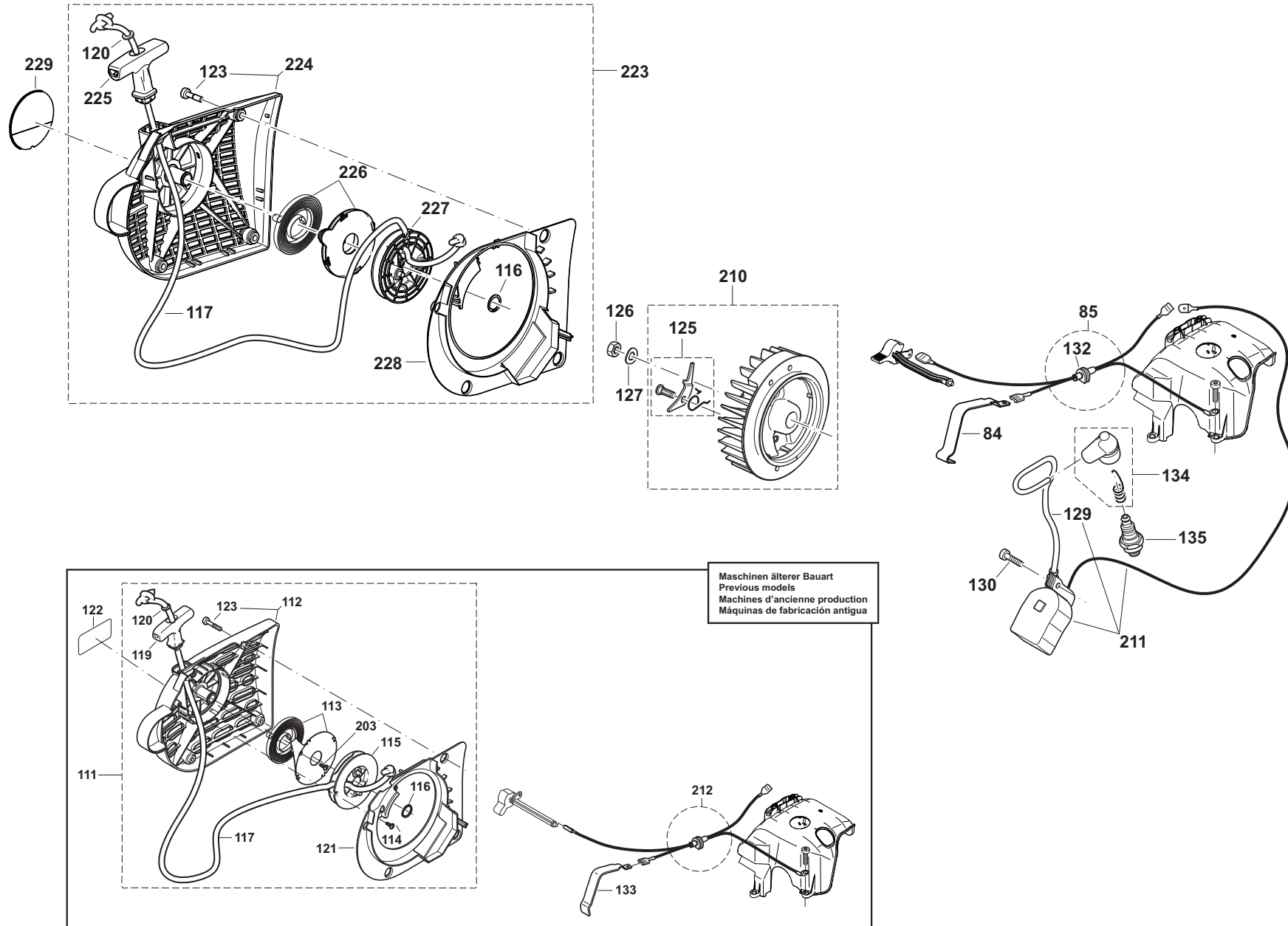

DPC6430, DPC6431, DPC7330, DPC7331, DPC8131, DPC8132, DPC6440, DPC6441, DPC7340, DPC7341, DPC6430, DPC7331, DPC8131, DPC8132, DPC6440, DPC7341, DPC6430, DPC6431, DPC7330, DPC7331, DPC8131, DPC8132, DPC6440, DPC6441, DPC7340, DPC7341

5

Anwervorrichtung, Magnetzünder
 Starter assy., ignition assy.
 Dispositif de démarrage, volant magnétique
 Dispositivo arranque, volante magnético



Seite / Page	Pos.	DPC6430	DPC6431	DPC7330	DPC7331	DPC8131	DPC8132	DPC6440	DPC6441	DPC7340	DPC7341	DPC6430 (UK)	DPC7331 (UK)	DPC8131 (UK)	DPC8132 (UK)	DPC6440 (UK)	DPC7341 (UK)	DPC6430 (USA)	DPC6431 (USA)	DPC7330 (USA)	DPC7331 (USA)	DPC8131 (USA)	DPC8132 (USA)	DPC6440 (USA)	DPC6441 (USA)	DPC7340 (USA)	DPC7341 (USA)	Teil-Nr. Part No. No. de pièce No. de pieza	Hinweise Notes Renseign. Nota	Bezeichnung	Spezifikation Specification	Description	Désignation	Denominación
5	84	1	1	1	1	1	1	1	1	1	1	1	1	1	1	1	1	1	1	1	1	1	1	1	1	1	1	957 395 001		REP.-SATZ CHOKEWELLE / KONTAKTFEDER		KIT CHOKE SHAFT / CONTACT SPRING	JEU AXE CLAPET D'AIR / RESSORT DE CONTACT	JUEGO EJE VÁLVULA AIRE / RESORTE DE CONTACTO
5	85	1	1	1	1	1	1	1	1	1	1	1	1	1	1	1	1	1	1	1	1	1	1	1	1	1	965 605 511		KABEL MIT STECKER		CABLE WITH PLUG	CÂBLE AVEC PRISE	CABLE CON ENCHUFE	
5	111	1	1	1	1	1	1	1	1	1	1	1	1	1	1	1	1	1	1	1	1	1	1	1	1	1	394 112 642		ANWERFVOR RICHTUNG KPL., GRAU	INC. 112-117,119-121,203	STARTER ASSY.	DISPOS. DE DÉMARRAGE CPL.	DISPOS. DE ARRANQUE CPL.	
5	112	1	1	1	1	1	1	1	1	1	1	1	1	1	1	1	1	1	1	1	1	1	1	1	1	1	394 112 621		STARTERGEH ÄUSE, GRAU	INC. 123	HOUSING	CARTER	CÁRTER	
5	113	1	1	1	1	1	1	1	1	1	1	1	1	1	1	1	1	1	1	1	1	1	1	1	1	1	394 163 020		RÜCKHOLFED ER IM GEHÄUSE		REWIND SPRING	RESSORT DE RAPPEL	RESORTE RETENC.	
5	114	2	2	2	2	2	2	2	2	2	2	2	2	2	2	2	2	2	2	2	2	2	2	2	2	2	915 135 100		SCHNEIDSCH RAUBE	3,5x9,5	SCREW	VIS	TORNILLO	
5	115	1	1	1	1	1	1	1	1	1	1	1	1	1	1	1	1	1	1	1	1	1	1	1	1	1	394 162 040		SEILTROMME L		CABLE DRUM	TAMBOUR DE CÂBLE	TAMBOUR PARA CORDÓN	
5	116	1	1	1	1	1	1	1	1	1	1	1	1	1	1	1	1	1	1	1	1	1	1	1	1	1	929 314 100		SICHERUNGS RING		SNAP RING	CIRCLIP	ANILLO SEGURIDAD	
5	117	1	1	1	1	1	1	1	1	1	1	1	1	1	1	1	1	1	1	1	1	1	1	1	1	1	394 164 020		ANWERFSEIL SCHWARZ	ø4 x 1000mm	STARTER ROPE BLACK	CÂBLE DE DÉMARRAGE NOIR	CORDÓN DE ARRANQUE NEGRO	
5	117	1	1	1	1	1	1	1	1	1	1	1	1	1	1	1	1	1	1	1	1	1	1	1	1	1	122 164 010		ANWERFSEIL	ø4 x 1000mm	STARTER ROPE	CÂBLE DE DÉMARRAGE	CORDÓN DE ARRANQUE	
5	119	1	1	1	1	1	1	1	1	1	1	1	1	1	1	1	1	1	1	1	1	1	1	1	1	1	001 161 020		ANWERFGRIF F		STARTER GRIP	POIGNÉE DE LANCEMENT	TIRADOR DE ARRANQUE	
5	120	1	1	1	1	1	1	1	1	1	1	1	1	1	1	1	1	1	1	1	1	1	1	1	1	1	928 405 000		SPANNSCHEI BE		DISC	DISQUE	ARANDELA	
5	121	1	1	1	1	1	1	1	1	1	1	1	1	1	1	1	1	1	1	1	1	1	1	1	1	1	394 112 141		LUFTFÜHRUN G		AIR GUIDE PLATE	GUIDE D'AIR	CONDUCTO DE AIRE	
5	122	1	1	1	1	1	1	1	1	1	1	1	1	1	1	1	1	1	1	1	1	1	1	1	1	1	980 115 214		SCHILD	MAKITA	LABEL	PLAQUE	CALCOMANIA	
5	123	4	4	4	4	4	4	4	4	4	4	4	4	4	4	4	4	4	4	4	4	4	4	4	4	4	908 605 205		SCHRAUBE INNEN6RD	M5x20	H.L. SOCKET HEAD BOLT	VIS	TORNILLO	
5	125	2	2	2	2	2	2	2	2	2	2	2	2	2	2	2	2	2	2	2	2	2	2	2	2	2	031 166 010		ANWERFKLIN KE KPL.		STARTER RATCHET	CLIQUET CPL.	TRINQUETE ARRANQUE CPL.	
5	126	1	1	1	1	1	1	1	1	1	1	1	1	1	1	1	1	1	1	1	1	1	1	1	1	1	920 208 024		6KT-MUTTER	M8x1	HEXAGONAL NUT	ECROU HEXAGONAL	TUERCA HEXAGONAL	

DPC6430, DPC6431, DPC7330, DPC7331, DPC8131,
 DPC8132, DPC6440, DPC6441, DPC7340, DPC7341,
 DPC6430, DPC7331, DPC8131, DPC8132, DPC6440
 , DPC7341 , DPC6430 , DPC6431 , DPC7330 , DPC7331
 , DPC8131 , DPC8132 , DPC6440 , DPC6441 ,
 DPC7340 , DPC7341

5

Anwerfvorrichtung, Magnetzünder
 Starter Assy., ignition Assy.
 Dispositif de démarrage, volant magnétique
 Dispositivo arranque, volante magnético

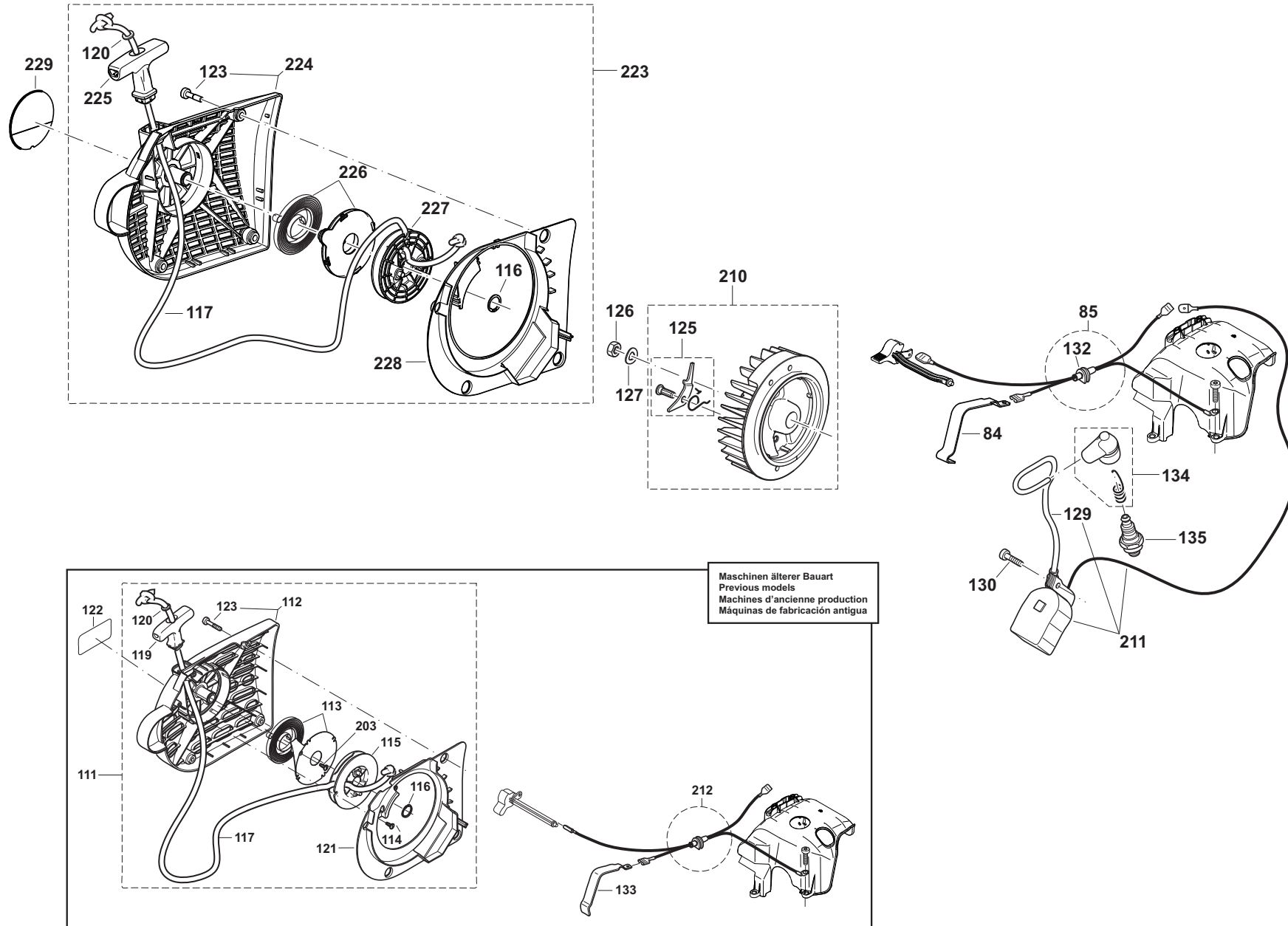

Maschinen älterer Bauart
 Previous models
 Machines d'ancienne production
 Máquinas de fabricación antigua

DPC6430, DPC6431, DPC7330, DPC7331, DPC8131,
DPC8132, DPC6440, DPC6441, DPC7340, DPC7341,
DPC6430, DPC7331, DPC8131, DPC8132, DPC6440
, DPC7341, DPC6430, DPC6431, DPC7330, DPC7331
, DPC8131, DPC8132, DPC6440, DPC6441,
DPC7340, DPC7341

5

Anwervorrichtung, Magnetzünd
Starter assy., ignition assy.
Dispositif de démarrage, volant magnétique
Dispositivo arranque, volante magnético



Seite / Page	Pos.	DPC6430	DPC6431	DPC7330	DPC7331	DPC8131	DPC8132	DPC6440	DPC6441	DPC7340	DPC7341	DPC6430 (UK)	DPC7331 (UK)	DPC8131 (UK)	DPC8132 (UK)	DPC6440 (UK)	DPC7341 (UK)	DPC6430 (USA)	DPC6431 (USA)	DPC7330 (USA)	DPC7331 (USA)	DPC8131 (USA)	DPC8132 (USA)	DPC6440 (USA)	DPC6441 (USA)	DPC7340 (USA)	DPC7341 (USA)	Teil-Nr. Part No. No. de pièce No. de pieza	Hinweise Notes Renseign. Nota	Bezeichnung	Spezifikation Specification	Description	Désignation	Denominación
5	127	1	1	1	1	1	1	1	1	1	1	1	1	1	1	1	1	1	1	1	1	1	1	1	1	1	1	926 208 001		FEDERSCHEIBE	B8	SPRING WASHER	RONDELLE ÉLASTIQUE	DISCO AMORTIGUADOR
5	129	m	m	m	m	m	m	m	m	m	m	m	m	m	m	m	m	m	m	m	m	m	m	m	m	m	m	970 310 200		ZÜNDLEITUNG	360mm; 141/8"	IGNITION CABLE	CÂBLE D'ALLUMAGE	CABLE ENCENDIDO
5	130	2	2	2	2	2	2	2	2	2	2	2	2	2	2	2	2	2	2	2	2	2	2	2	2	2	908 605 205		SCHRAUBE INNEN6RD	M5x20	H.L. SOCKET HEAD BOLT	VIS	TORNILLO	
5	132	1	1	1	1	1	1	1	1	1	1	1	1	1	1	1	1	1	1	1	1	1	1	1	1	1	965 401 016		GUMMITÜLLE		RUBBER BUSH	GAINE CAOUTCHOUC	BOQUILLA DE CAUCHO	
5	133	1	1	1	1	1	1	1	1	1	1	1	1	1	1	1	1	1	1	1	1	1	1	1	1	1	394 146 013		KONTAKTFEDER		CONTACT SPRING	RESSORT DE CONTACT	RESORTE DE CONTACTO	
5	134	1	1	1	1	1	1	1	1	1	1	1	1	1	1	1	1	1	1	1	1	1	1	1	1	1	957 604 260		ZÜNDKERZEN STECKER KPL.		SPARK PLUG CAP CPL.	FICHE DE BOUGIE, CPL.	TAPA DE BUJIA CPL.	
5	135	1	1	1	1	1	1	1	1	1	1	1	1	1	1	1	1	1	1	1	1	1	1	1	1	1	965 603 021		ZÜNDKERZE		SPARK PLUG	BOUGIE	BUJÍA	
5	203	1	1	1	1	1	1	1	1	1	1	1	1	1	1	1	1	1	1	1	1	1	1	1	1	1	915 135 100		SCHNEIDSCHRAUBE	3,5x9,5	SCREW	VIS	TORNILLO	
5	210	1	1	1	1	1	1	1	1	1	1	1	1	1	1	1	1	1	1	1	1	1	1	1	1	1	394 141 090		POLRAD KPL.	INC. 125	FLYWHEEL ASSY.	ROUE POLAIRE CPL.	VOLANTE ENCENDIDO	
5	211	1	1	1	1	1	1	1	1	1	1	1	1	1	1	1	1	1	1	1	1	1	1	1	1	1	394 143 030		MAGNETZÜNDER		IGNITION COIL	BOBINE D'ALLUMAGE	BOBINA ENCENDIDO	
5	212	1	1	1	1	1	1	1	1	1	1	1	1	1	1	1	1	1	1	1	1	1	1	1	1	1	965 605 510		KABEL MIT STECKER		CABLE WITH PLUG	CÂBLE AVEC PRISE	CABLE CON ENCHUFE	
5	223	1	1	1	1	1	1	1	1	1	1	1	1	1	1	1	1	1	1	1	1	1	1	1	1	1	395 160 600	2010 =>	ANWERFVORRICHTUNG KPL. BLAU	blue, highly polishedINC. 116,117,120,224-228	STARTER ASSY. BLUE	DISPOS. DE DÉMARRAGE CPL. BLEU	DISPOS. DE ARRANQUE CPL. AZUL	
5	224	1	1	1	1	1	1	1	1	1	1	1	1	1	1	1	1	1	1	1	1	1	1	1	1	1	395 160 630	2010 =>	STARTERGEHÄUSE, BLAU	blue, highly polishedINC. 123	HOUSING	CARTER	CÁRTER	
5	225	1	1	1	1	1	1	1	1	1	1	1	1	1	1	1	1	1	1	1	1	1	1	1	1	1	181 164 010		ANWERFGRIF		STARTER KNOB	POIGNÉE DE LANCEMENT	TIRADOR DE ARRANQUE	
5	226	1	1	1	1	1	1	1	1	1	1	1	1	1	1	1	1	1	1	1	1	1	1	1	1	1	181 163 050		RÜCKHOLFEDER IM GEHÄUSE		REWIND SPRING IN HOUSING	RESSORT RAPPEL DANS BOÎT	RESORTE RETENC. EN CAJA	
5	227	1	1	1	1	1	1	1	1	1	1	1	1	1	1	1	1	1	1	1	1	1	1	1	1	1	395 162 020		SEILTROMMEL KPL.		CABLE DRUM CPL.	TAMBOUR DE CÂBLE CPL.	TAMBOUR PARA CORDÓN CPL.	
5	228	1	1	1	1	1	1	1	1	1	1	1	1	1	1	1	1	1	1	1	1	1	1	1	1	1	395 118 170		LUFTFÜHRUNG		AIR GUIDE PLATE	GUIDE D'AIR	CONDUCTO DE AIRE	
5	229	1	1	1	1	1	1	1	1	1	1	1	1	1	1	1	1	1	1	1	1	1	1	1	1	1	980 115 760		SCHILD	MAKITA	LABEL	PLAQUE	CALCOMANIA	

DPC6430, DPC6431, DPC7330, DPC7331, DPC8131,
DPC8132, DPC6440, DPC6441, DPC7340, DPC7341,
DPC6430, DPC7331, DPC8131, DPC8132, DPC6440
, DPC7341, DPC6430, DPC6431, DPC7330, DPC7331
, DPC8131, DPC8132, DPC6440, DPC6441,
DPC7340, DPC7341

6

Zylinder, Kurbeltrieb, Kupplung
Cylinder, crankshaft, clutch
Cylindre, vilebrequin, embrayage
Cilindro, cigüeñal, embrague

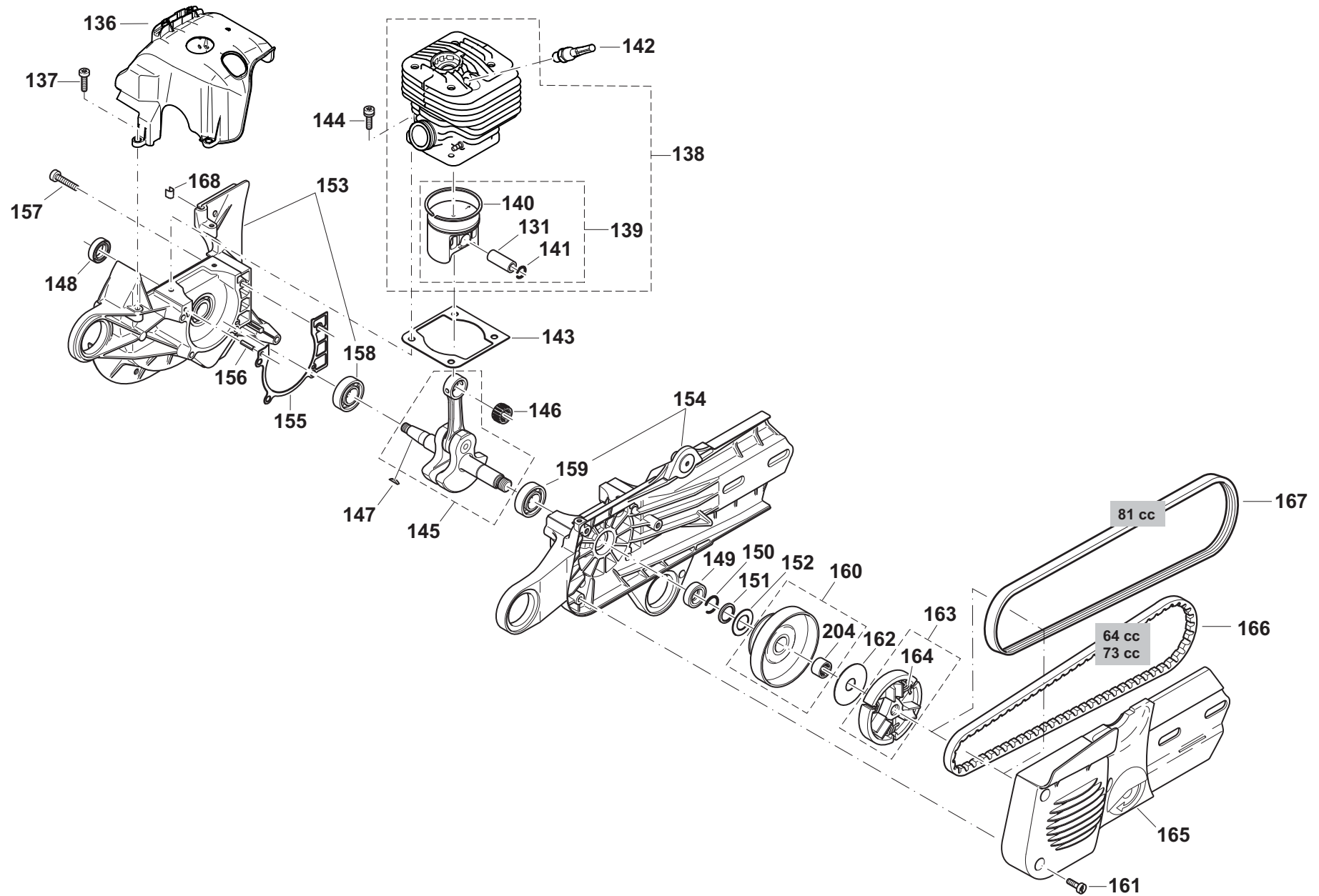

DPC6430, DPC6431, DPC7330, DPC7331, DPC8131, DPC8132, DPC6440, DPC6441, DPC7340, DPC7341, DPC6430, DPC7331, DPC8131, DPC8132, DPC6440, DPC7341, DPC6430, DPC6431, DPC7330, DPC7331, DPC8131, DPC8132, DPC6440, DPC6441, DPC7340, DPC7341

6

Zylinder, Kurbeltrieb, Kupplung
Cylinder, crankshaft, clutch
Cylindre, vilebrequin, embrayage
Cilindro, cigüeñal, embrague



Seite / Page	Pos.	DPC6430	DPC6431	DPC7330	DPC7331	DPC8131	DPC8132	DPC6440	DPC6441	DPC7340	DPC7341	DPC6430 (UK)	DPC7331 (UK)	DPC8131 (UK)	DPC8132 (UK)	DPC6440 (UK)	DPC7341 (UK)	DPC6430 (USA)	DPC6431 (USA)	DPC7330 (USA)	DPC7331 (USA)	DPC8131 (USA)	DPC8132 (USA)	DPC6440 (USA)	DPC6441 (USA)	DPC7340 (USA)	DPC7341 (USA)	Teil-Nr. Part No. No. de pièce No. de pieza	Hinweise Notes Renseign. Nota	Bezeichnung	Spezifikation Specification	Description	Désignation	Denominación
6	131	1	1	1	1			1	1	1	1	1	1			1	1	1	1	1	1			1	1	1	1	119 132 030		KOLBENBOLZEN		PISTON PIN	AXE DE PISTON	PERNO DE PISTÓN
6	131					1	1							1	1												038 132 040		KOLBENBOLZEN		PISTON PIN	AXE DE PISTON	PERNO DE PISTÓN	
6	136	1	1	1	1	1	1	1	1	1	1	1	1	1	1	1	1	1	1	1	1	1	1	1	1	1	395 131 041		KÜHLLUFTHAUBE		COOLING HOOD	CAPOT	CUBIERTA	
6	137	3	3	3	3	3	3	3	3	3	3	3	3	3	3	3	3	3	3	3	3	3	3	3	3	3	909 005 155		SCHRAUBE	M5x15	BOLT	VIS	TORNILLO	
6	138	1	1					1	1							1	1										327 130 140		ZYLINDER / KOLBEN KPL.	ø 47 HeadDecoINC. 139	CYLINDER / PISTON CPL.	CYLINDRE ET PISTON CPL.	CILINDRO CON PISTÓN CPL.	
6	138			1	1					1	1								1	1							395 130 140		ZYLINDER / KOLBEN KPL.	ø 50 HeadDecoINC. 139	CYLINDER / PISTON CPL.	CYLINDRE ET PISTON CPL.	CILINDRO CON PISTÓN CPL.	
6	138					1	1							1	1												326 130 140		ZYLINDER / KOLBEN KPL.	ø 52 HeadDecoINC. 139	CYLINDER / PISTON CPL.	CYLINDRE ET PISTON CPL.	CILINDRO CON PISTÓN CPL.	
6	139	1	1					1	1							1	1										325 132 034		KOLBEN KPL.	ø 47INC. 131,140,141	PISTON CPL.	PISTON CPL.	PISTÓN CPL.	
6	139			1	1					1	1									1	1						395 132 050		KOLBEN KPL.	ø 50INC. 131,140,141	PISTON CPL.	PISTON CPL.	PISTÓN CPL.	
6	139					1	1							1	1												038 132 002		KOLBEN AB KPL.	ø 52INC. 131,140,141	PISTON CPL.	PISTON CPL.	PISTÓN CPL.	
6	140	1	1					1	1							1	1										325 132 050		KOLBENRING	ø 47	PISTON RING	SEGMENT DE PISTON	SEGMENTO DE PISTÓN	
6	140			1	1					1	1									1	1						394 132 020		KOLBENRING	ø 50	PISTON RING	SEGMENT DE PISTON	SEGMENTO DE PISTÓN	
6	140					1	1							1	1												038 132 020		KOLBENRING	ø 52	PISTON RING	SEGMENT DE PISTON	SEGMENTO DE PISTÓN	
6	141	2	2	2	2	2	2	2	2	2	2	2	2	2	2	2	2	2	2	2	2	2	2	2	2	2	119 132 060		SPRENGRING	C12X1	SPRING RING	ANNEAU-RESSORT	ANILLO ELÁSTICO	
6	142	1	1	1	1	1	1	1	1	1	1	1	1	1	1	1	1	1	1	1	1	1	1	1	1	1	395 118 071		DEKOMPRESSIONSVENTIL	HeadDeco	VALVE	SOUPAPE	VÁLVULA	
6	143	1	1	1	1	1	1	1	1	1	1	1	1	1	1	1	1	1	1	1	1	1	1	1	1	1	965 531 160		ZYLINDERFUßDICHTUNG, METALL		GASKET, METAL	JOINT, MÉTAL	JUNTA, METAL	
6	144	4	4	4	4	4	4	4	4	4	4	4	4	4	4	4	4	4	4	4	4	4	4	4	4	4	908 805 235		INNENSTERNSCHRAUBE MIT SPANNSCHEIBE	M5x23	SCREW	VIS	TORNILLO	
6	145	1	1	1	1			1	1	1	1	1	1			1	1	1	1	1	1						394 120 011		KURBELWELLE KPL.		CRANKSHAFT CPL.	VILEBREQUIN CPL.	CIGÜEÑAL CPL.	
6	145					1	1																				326 120 101		KURBELWELLE KPL.		CRANKSHAFT CPL.	VILEBREQUIN CPL.	CIGÜEÑAL CPL.	

DPC6430, DPC6431, DPC7330, DPC7331, DPC8131,
DPC8132, DPC6440, DPC6441, DPC7340, DPC7341,
DPC6430, DPC7331, DPC8131, DPC8132, DPC6440
, DPC7341, DPC6430, DPC6431, DPC7330, DPC7331
, DPC8131, DPC8132, DPC6440, DPC6441,
DPC7340, DPC7341

6

Zylinder, Kurbeltrieb, Kupplung
Cylinder, crankshaft, clutch
Cylindre, vilebrequin, embrayage
Cilindro, cigüeñal, embrague

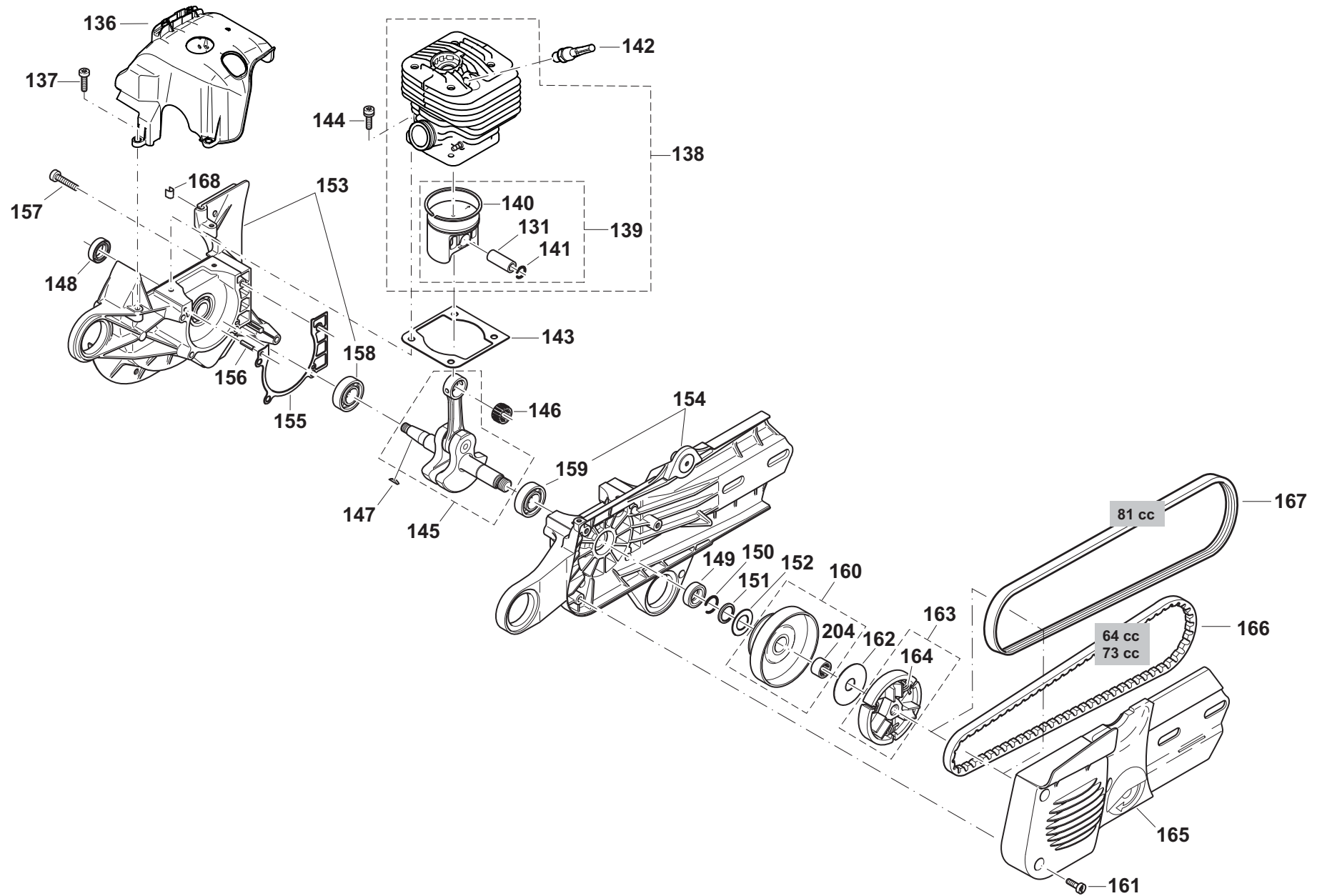

DPC6430, DPC6431, DPC7330, DPC7331, DPC8131, DPC8132, DPC6440, DPC6441, DPC7340, DPC7341, DPC6430, DPC7331, DPC8131, DPC8132, DPC6440, DPC7341, DPC6430, DPC6431, DPC7330, DPC7331, DPC8131, DPC8132, DPC6440, DPC6441, DPC7340, DPC7341

6

Zylinder, Kurbeltrieb, Kupplung
Cylinder, crankshaft, clutch
Cylindre, vilebrequin, embrayage
Cilindro, cigüeñal, embrague



Seite / Page	Pos.	DPC6430	DPC6431	DPC7330	DPC7331	DPC8131	DPC8132	DPC6440	DPC6441	DPC7340	DPC7341	DPC6430 (UK)	DPC7331 (UK)	DPC8131 (UK)	DPC8132 (UK)	DPC6440 (UK)	DPC7341 (UK)	DPC6430 (USA)	DPC6431 (USA)	DPC7330 (USA)	DPC7331 (USA)	DPC8131 (USA)	DPC8132 (USA)	DPC6440 (USA)	DPC6441 (USA)	DPC7340 (USA)	DPC7341 (USA)	Teil-Nr. Part No. No. de pièce No. de pieza	Hinweise Notes Renseign. Nota	Bezeichnung	Spezifikation Specification	Description	Désignation	Denominación	
6	146	1	1	1	1	1	1	1	1	1	1	1	1	1	1	1	1	1	1	1	1	1	1	1	1	1	1	1	962 210 121		NADELKRANZ		NEEDLE CAGE	CAGE À AIGUILLES	JAULA DE AGUJAS
6	147	1	1	1	1	1	1	1	1	1	1	1	1	1	1	1	1	1	1	1	1	1	1	1	1	1	1	1	939 630 370		SCHEIBENFEDE R		KEY	CLAVETTE	CHAVETA
6	148	1	1	1	1	1	1	1	1	1	1	1	1	1	1	1	1	1	1	1	1	1	1	1	1	1	1	962 900 052		RADIALDICHTUNG	Ø15/24x7	RADIAL RING	JOINT RADIAL	JUNTA RADIAL	
6	149	1	1	1	1	1	1	1	1	1	1	1	1	1	1	1	1	1	1	1	1	1	1	1	1	1	1	962 900 052		RADIALDICHTUNG	Ø15/24x7	RADIAL RING	JOINT RADIAL	JUNTA RADIAL	
6	150	1	1	1	1	1	1	1	1	1	1	1	1	1	1	1	1	1	1	1	1	1	1	1	1	1	1	930 916 160		SPRENGRING		SPRING RING	ANNEAU-RESSORT	ANILLO ELÁSTICO	
6	151	1	1	1	1	1	1	1	1	1	1	1	1	1	1	1	1	1	1	1	1	1	1	1	1	1	1	394 245 010		ANSCHLAGRING, GEHÄRTET, VERZINKT		STOP RING	BAGUE DE BUTÉE	ANILLO DE DETEN.	
6	152	1	1	1	1	1	1	1	1	1	1	1	1	1	1	1	1	1	1	1	1	1	1	1	1	1	1	394 182 020		FÜHRUNGSSCHEIBE		GUIDE DISC	DISQUE DE GUIDAGE	DISCO DE GUÍA	
6	153	1	1	1	1	1	1	1	1	1	1	1	1	1	1	1	1	1	1	1	1	1	1	1	1	1	1	326 111 731		KURBELGEHÄUSE KPL. MS, SCHWARZ	INC. 76,158,205,213	CRANKC., MAG. SIDE	CARTER-COTÉ, MAGN.	CÁRTER CIG., LADO MAG.	
6	154	1	1	1	1	1	1	1	1	1	1	1	1	1	1	1	1	1	1	1	1	1	1	1	1	1	1	326 111 740		KURBELGEHÄUSE KPL. KS, SCHWARZ	INC. 159	CRANKC., CLUTCH SIDE	CARTER-COTÉ, EMBR.	CÁRTER CIG., LADO EMBR.	
6	155	1	1	1	1	1	1	1	1	1	1	1	1	1	1	1	1	1	1	1	1	1	1	1	1	1	1	965 531 111		KURBELGEHÄUSEDICHTUNG		GASKET	JOINT	JUNTA	
6	156	2	2	2	2	2	2	2	2	2	2	2	2	2	2	2	2	2	2	2	2	2	2	2	2	2	2	2	936 430 160		SPIRALSPANNSTIFT	3X16	CLAMPING PIN	GOUPILLE	PASADOR
6	157	5	5	5	5	5	5	5	5	5	5	5	5	5	5	5	5	5	5	5	5	5	5	5	5	5	5	5	908 005 305		INNENSTERN-SCHRAUBE	M5x30	SCREW	VIS	TORNILLO
6	158	1	1	1	1	1	1	1	1	1	1	1	1	1	1	1	1	1	1	1	1	1	1	1	1	1	1	1	960 102 152		KUGELLAGER (EINKLEBEN)	6202	BALL BEARING (USE GLUE)	ROULEMENT À BILLES (À COLLER)	RODAM. DE BOLAS (A COLAR)
6	159	1	1	1	1	1	1	1	1	1	1	1	1	1	1	1	1	1	1	1	1	1	1	1	1	1	1	1	960 102 152		KUGELLAGER (EINKLEBEN)	6202	BALL BEARING (USE GLUE)	ROULEMENT À BILLES (À COLLER)	RODAM. DE BOLAS (A COLAR)
6	160	1	1	1	1	1	1	1	1	1	1	1	1	1	1	1	1	1	1	1	1	1	1	1	1	1	1	394 223 025		KUPPLUNGSTRÖMMEL KPL.	INC. 204	CLUTCH DRUM CPL.	TAMBOUR CPL.	TAMBOR CPL.	
6	160																											326 223 023		KUPPLUNGSTRÖMMEL KPL.	Ø400mm-80mlNC. 204	CLUTCH DRUM CPL.	TAMBOUR CPL.	TAMBOR CPL.	
6	161	3	3	3	3	3	3	3	3	3	3	3	3	3	3	3	3	3	3	3	3	3	3	3	3	3	3	3	908 605 145		INNENSTERN-SCHLITZ-SCHRAUBE	M5x14	SCREW	VIS	TORNILLO
6	162	1	1	1	1	1	1	1	1	1	1	1	1	1	1	1	1	1	1	1	1	1	1	1	1	1	1	1	001 182 042		FÜHRUNGSSCHEIBE	44,5x1x12	DISC	DISQUE	DISCO

DPC6430, DPC6431, DPC7330, DPC7331, DPC8131,
DPC8132, DPC6440, DPC6441, DPC7340, DPC7341,
DPC6430, DPC7331, DPC8131, DPC8132, DPC6440
, DPC7341, DPC6430, DPC6431, DPC7330, DPC7331
, DPC8131, DPC8132, DPC6440, DPC6441,
DPC7340, DPC7341

6

Zylinder, Kurbeltrieb, Kupplung
Cylinder, crankshaft, clutch
Cylindre, vilebrequin, embrayage
Cilindro, cigüeñal, embrague

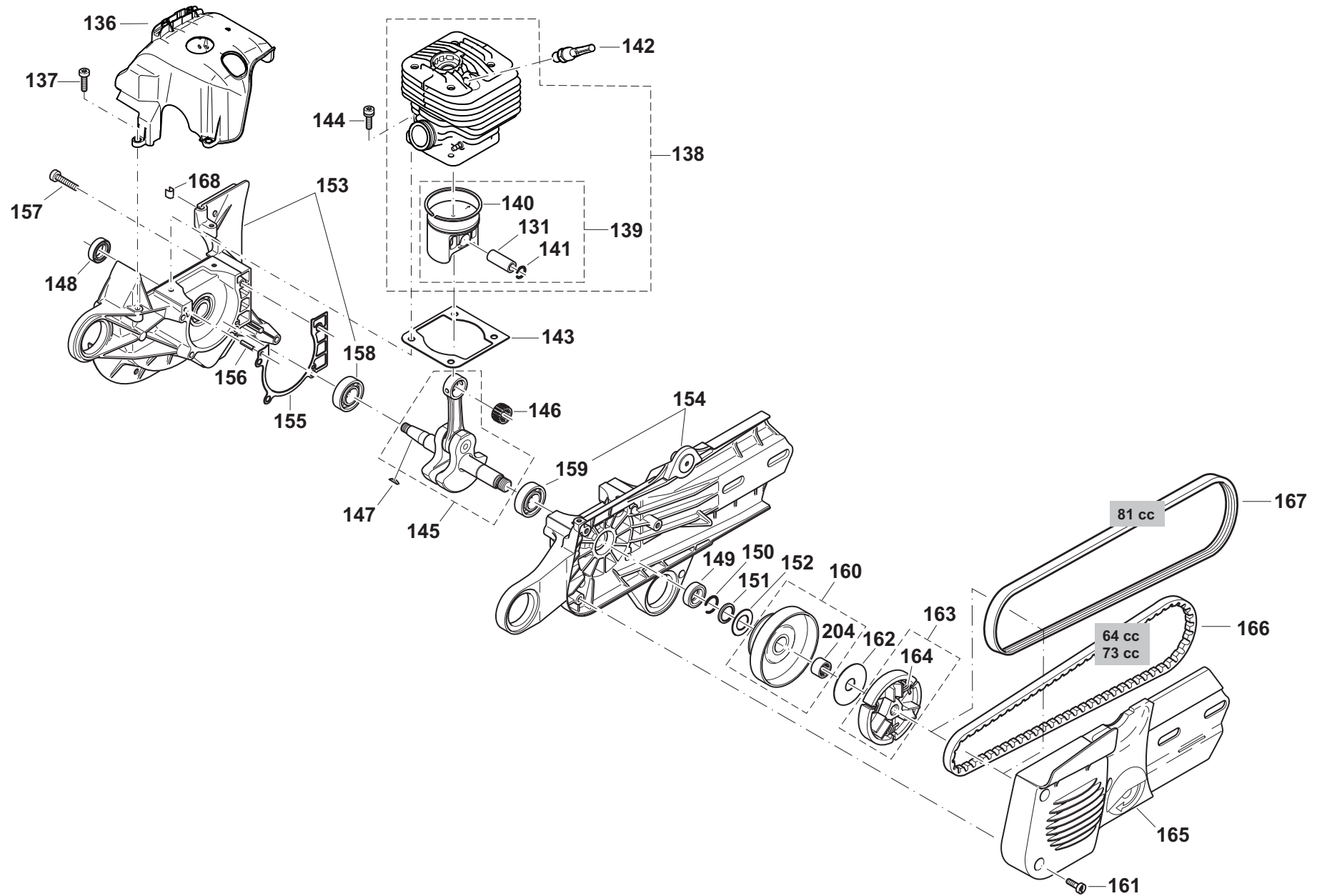

DPC6430, DPC6431, DPC7330, DPC7331, DPC8131,
DPC8132, DPC6440, DPC6441, DPC7340, DPC7341,
DPC6430, DPC7331, DPC8131, DPC8132, DPC6440
, DPC7341, DPC6430, DPC6431, DPC7330, DPC7331
, DPC8131, DPC8132, DPC6440, DPC6441,
DPC7340, DPC7341

6

Zylinder, Kurbeltrieb, Kupplung
Cylinder, crankshaft, clutch
Cylindre, vilebrequin, embrayage
Cilindro, cigüeñal, embrague



Seite / Page	Pos.	DPC6430	DPC6431	DPC7330	DPC7331	DPC8131	DPC8132	DPC6440	DPC6441	DPC7340	DPC7341	DPC6430 (UK)	DPC7331 (UK)	DPC8131 (UK)	DPC8132 (UK)	DPC6440 (UK)	DPC7341 (UK)	DPC6430 (USA)	DPC6431 (USA)	DPC7330 (USA)	DPC7331 (USA)	DPC8131 (USA)	DPC8132 (USA)	DPC6440 (USA)	DPC6441 (USA)	DPC7340 (USA)	DPC7341 (USA)	Teil-Nr. Part No. No. de pièce No. de pieza	Hinweise Notes Renseign. Nota	Bezeichnung	Spezifikation Specification	Description	Désignation	Denominación	
6	163	1	1	1	1	1	1	1	1	1	1	1	1	1	1	1	1	1	1	1	1	1	1	1	1	1	1	1	010 180 024		KUPPLUNG KPL.	INC. 164	CLUTCH ASSY.	EMBRAYAGE CPL.	EMBRAGUE CPL.
6	164	3	3	3	3	3	3	3	3	3	3	3	3	3	3	3	3	3	3	3	3	3	3	3	3	3	3	3	024 184 021		ZUGFEDER		SPRING	RESSORT	RESORTE
6	165	1	1	1	1	1	1	1	1	1	1		1	1	1		1	1	1	1	1	1	1	1	1	1	1	395 213 670	2010 =>	ABDECKUNG MIT SCHLITZEN, BLAU	blue, highly polished	COVER	COUVERCLE	CUBIERTA	
6	165											1				1												395 213 680	U.K.	ABDECKUNG OHNE SCHLITZE, BLAU	blue, highly polished	COVER -DO NOT USE ON 73CCM MACHINES	COUVERCLE	CUBIERTA	
6	166	1	1	1	1			1	1	1	1	1	1			1	1	1	1	1			1	1	1	1	1	965 300 470		KEILRIEMEN		V-BELT	COURROIE TRAPEZ	CORREA ESTRECHO	
6	167						1								1								1					965 300 481		KEILRIPPENRIE MEN	ø400mm-80m	V-BELT	COURROIE TRAPEZ	CORREA ESTRECHO	
6	167					1								1														965 300 490		KEILRIPPENRIE MEN	ø350mm-80m	V-BELT	COURROIE TRAPEZ	CORREA ESTRECHO	
6	168	1	1	1	1	1	1	1	1	1	1	1	1	1	1	1	1	1	1	1	1	1	1	1	1	1	1	965 402 870		FIXIERGUMMI	set=35 pcs.	RUBBER PLATE	PLAQUE DE CAOUTCH.	PLANCHA DE CAUCHO	
6	204	1	1	1	1	1	1	1	1	1	1	1	1	1	1	1	1	1	1	1	1	1	1	1	1	1	1	962 300 017		NADELHÜLSE		NEEDLE BUSH	ROULEMENT À AIGUILLES	JAULA DE AGUJAS	

DPC6430, DPC6431, DPC7330, DPC7331, DPC8131,
DPC8132, DPC6440, DPC6441, DPC7340, DPC7341,
DPC6430, DPC7331, DPC8131, DPC8132, DPC6440
, DPC7341, DPC6430, DPC6431, DPC7330, DPC7331
, DPC8131, DPC8132, DPC6440, DPC6441,
DPC7340, DPC7341

7

Schneidvorsatz, Schutzhaube
Cutting device, protection hood
Dispositif de coupe, capot de protection
Dispositivo tranzadora, cubierta protectora

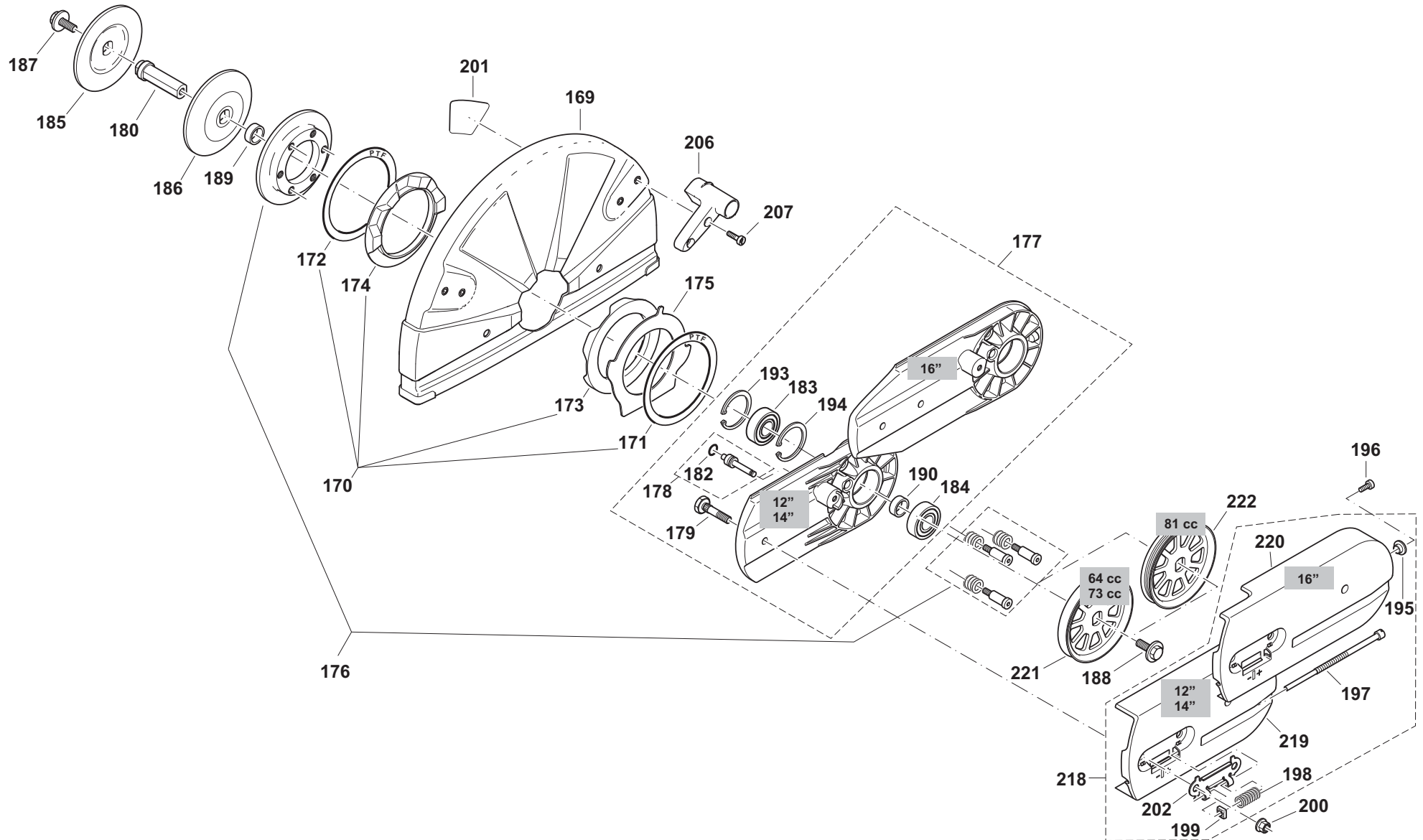

DPC6430, DPC6431, DPC7330, DPC7331, DPC8131, DPC8132, DPC6440, DPC6441, DPC7340, DPC7341, DPC6430, DPC7331, DPC8131, DPC8132, DPC6440, DPC7341, DPC6430, DPC6431, DPC7330, DPC7331, DPC8131, DPC8132, DPC6440, DPC6441, DPC7340, DPC7341

7

Schneidvorsatz, Schutzhaube
Cutting device, protection hood
Dispositif de coupe, capot de protection
Dispositivo tronzadora, cubierta protectora



Seite / Page	Pos.	DPC6430	DPC6431	DPC7330	DPC7331	DPC8131	DPC8132	DPC6440	DPC6441	DPC7340	DPC7341	DPC6430 (UK)	DPC7331 (UK)	DPC8131 (UK)	DPC8132 (UK)	DPC6440 (UK)	DPC7341 (UK)	DPC6430 (USA)	DPC6431 (USA)	DPC7330 (USA)	DPC7331 (USA)	DPC8131 (USA)	DPC8132 (USA)	DPC6440 (USA)	DPC6441 (USA)	DPC7340 (USA)	DPC7341 (USA)	Teil-Nr. Part No. No. de pièce No. de pieza	Hinweise Notes Renseign. Nota	Bezeichnung	Spezifikation Specification	Description	Désignation	Denominación
7	169	1		1				1		1		1			1		1		1					1		1		325 341 611		SCHUTZHAUBE, SILBER	ø 300mm; 12"	HOOD	CAPOT	CUBIERTA
7	169		1		1	1			1		1		1	1				1	1	1	1			1		1		394 341 051		SCHUTZHAUBE, SILBER	ø 350mm; 14"	HOOD	CAPOT	CUBIERTA
7	169						1							1									1					326 341 010		SCHUTZHAUBE, SILBER	ø 400mm; 16"	HOOD	CAPOT	CUBIERTA
7	170	1	1	1	1	1	1	1	1	1	1	1	1	1	1	1	1	1	1	1	1	1	1	1	1	1	1	957 342 011		AUFNAHME SCHUTZHAUBE KPL.	INC. 171-174	PROT. HOOD MOUNTING, CPL.	LOGEMENT CAPOT DE PROT. CPL.	ALOJAMIENTO CUB. PROT., CPL.
7	171	1	1	1	1	1	1	1	1	1	1	1	1	1	1	1	1	1	1	1	1	1	1	1	1	1	1	394 342 180		GLEITSCHLEIBE TEFLON		SLIDING DISC	DISQUE DE GLISSEMENT	ARANDELA DESLIZANTE
7	172	1	1	1	1	1	1	1	1	1	1	1	1	1	1	1	1	1	1	1	1	1	1	1	1	1	1	394 342 180		GLEITSCHLEIBE TEFLON		SLIDING DISC	DISQUE DE GLISSEMENT	ARANDELA DESLIZANTE
7	173	1	1	1	1	1	1	1	1	1	1	1	1	1	1	1	1	1	1	1	1	1	1	1	1	1	1	965 404 900		GUMMIRING AUßEN		RUBBER RING EXT.	BAGUE EN CAOUTCHOUC EXT.	ANILLO DE GOMA EXTERIOR
7	174	1	1	1	1	1	1	1	1	1	1	1	1	1	1	1	1	1	1	1	1	1	1	1	1	1	1	965 404 920		GUMMIRING INNEN		RUBBER RING INT.	BAGUE EN CAOUTCHOUC INT.	ANILLO DE GOMA INTERIOR
7	175	1	1	1	1	1	1	1	1	1	1	1	1	1	1	1	1	1	1	1	1	1	1	1	1	1	1	394 342 160		ANSCHLAGBLECH		IMPACT PLATE	TÔLE DE BUTÉE	CHAPA DE TOPE
7	176	1	1	1	1	1	1	1	1	1	1	1	1	1	1	1	1	1	1	1	1	1	1	1	1	1	1	394 342 211		DRUCKRING KPL., SCHWARZ		PRESSURE RING CPL.	BAGUE DE PRESSION CPL.	ANILLO DE PRESIÓN CPL.
7	177	1	1	1	1			1	1	1	1	1	1		1	1	1	1	1	1	1		1	1	1	1	1	394 211 740		SCHNEIDVORSATZ KPL., SCHWARZ	12", 14"INC. 178,179,182-184,190,193,194	CUTTING DEVICE ASSY.	DISPOSITIF DE COUPE CPL.	DISPOS. TRANZADORA CPL.
7	177					1								1								1						326 211 740		SCHNEIDVORSATZ KPL., SCHWARZ	16"INC. 178,179,182-184,190,193,194	CUTTING DEVICE ASSY.	DISPOSITIF DE COUPE CPL.	DISPOS. TRANZADORA CPL.
7	178	1	1	1	1	1	1	1	1	1	1	1	1	1	1	1	1	1	1	1	1	1	1	1	1	1	1	394 342 190		ANSCHLAGBOLZEN KPL.		BOLT CPL.	BOULON CPL.	BULON CPL.
7	179	2	2	2	2	2	2	2	2	2	2	2	2	2	2	2	2	2	2	2	2	2	2	2	2	2	2	394 211 091		BEFESTIGUNGSBOLZEN		TIGHTEN LOCKING BOLT	BOULON DE FIXATION	PERNO DE FIJACIÓN
7	180	1	1	1	1	1	1	1	1	1	1	1	1	1	1	1	1	1	1	1	1	1	1	1	1	1	1	394 228 101		ACHSE	ø 20mm	AXLE	AXE	EJE
7	180	1	1	1	1			1	1	1	1	1	1		1	1	1	1	1	1	1		1	1	1	1	1	394 228 130	Acc.	ACHSE	ø 22,2mm	AXLE	AXE	EJE
7	180	1	1	1	1			1	1	1	1	1	1		1	1	1	1	1	1	1		1	1	1	1	1	394 228 111		ACHSE	ø 25,4mm; 1"	AXLE	AXE	EJE
7	182	1	1	1	1	1	1	1	1	1	1	1	1	1	1	1	1	1	1	1	1	1	1	1	1	1	1	963 209 020		O-RING	9x2	PACKING RING	BAGUE-JOINT	ANILLO DE GUARNICIÓN

DPC6430, DPC6431, DPC7330, DPC7331, DPC8131,
 DPC8132, DPC6440, DPC6441, DPC7340, DPC7341,
 DPC6430, DPC7331, DPC8131, DPC8132, DPC6440
 , DPC7341, DPC6430, DPC6431, DPC7330, DPC7331
 , DPC8131, DPC8132, DPC6440, DPC6441,
 DPC7340, DPC7341

7

Schneidvorsatz, Schutzhaube
 Cutting device, protection hood
 Dispositif de coupe, capot de protection
 Dispositivo tranzadora, cubierta protectora

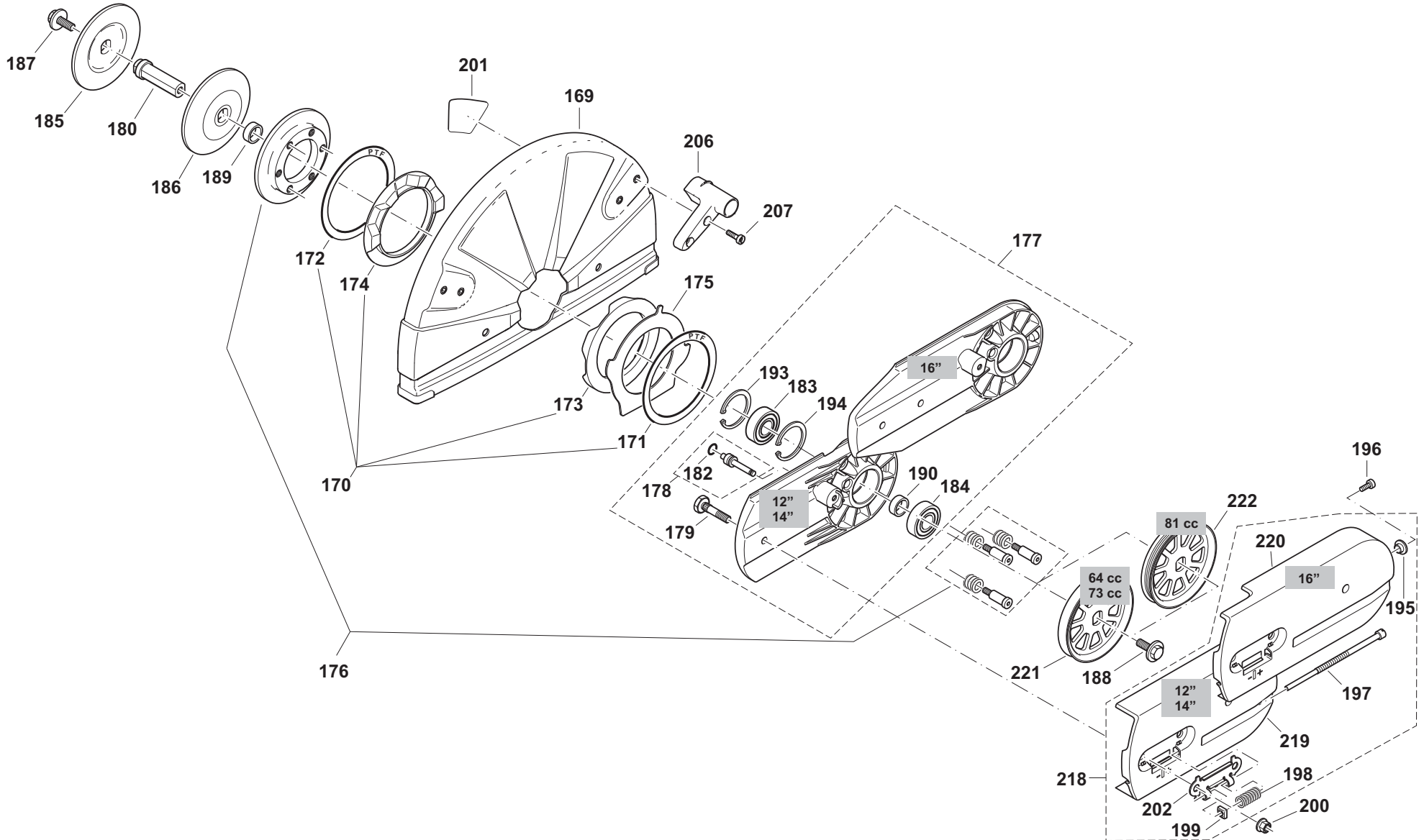

DPC6430, DPC6431, DPC7330, DPC7331, DPC8131, DPC8132, DPC6440, DPC6441, DPC7340, DPC7341, DPC6430, DPC7331, DPC8131, DPC8132, DPC6440, DPC7341, DPC6430, DPC6431, DPC7330, DPC7331, DPC8131, DPC8132, DPC6440, DPC6441, DPC7340, DPC7341

7

Schneidvorsatz, Schutzhaube
Cutting device, protection hood
Dispositif de coupe, capot de protection
Dispositivo tronzadora, cubierta protectora



Seite / Page	Pos.	DPC6430	DPC6431	DPC7330	DPC7331	DPC8131	DPC8132	DPC6440	DPC6441	DPC7340	DPC7341	DPC6430 (UK)	DPC7331 (UK)	DPC8131 (UK)	DPC8132 (UK)	DPC6440 (UK)	DPC7341 (UK)	DPC6430 (USA)	DPC6431 (USA)	DPC7330 (USA)	DPC7331 (USA)	DPC8131 (USA)	DPC8132 (USA)	DPC6440 (USA)	DPC6441 (USA)	DPC7340 (USA)	DPC7341 (USA)	Teil-Nr. Part No. No. de pièce No. de pieza	Hinweise Notes Renseign. Nota	Bezeichnung	Spezifikation Specification	Description	Désignation	Denominación
7	183	1	1	1	1	1	1	1	1	1	1	1	1	1	1	1	1	1	1	1	1	1	1	1	1	1	1	960 102 176		KUGELLAGER		BALL BEARING	ROULEMENT À BILLES	RODAMIENTO DE BOLAS
7	184	1	1	1	1	1	1	1	1	1	1	1	1	1	1	1	1	1	1	1	1	1	1	1	1	1	960 102 176		KUGELLAGER		BALL BEARING	ROULEMENT À BILLES	RODAMIENTO DE BOLAS	
7	185	1	1	1	1	1	1	1	1	1	1	1	1	1	1	1	1	1	1	1	1	1	1	1	1	1	326 228 020		SPANNFLANSCH	12"-16"	PRESSURE DISC	DISQUE DE PRESSION	DISCO DE PRESIÓN	
7	186	1	1	1	1	1	1	1	1	1	1	1	1	1	1	1	1	1	1	1	1	1	1	1	1	1	326 228 020		SPANNFLANSCH	12"-16"	PRESSURE DISC	DISQUE DE PRESSION	DISCO DE PRESIÓN	
7	187	1	1	1	1	1	1	1	1	1	1	1	1	1	1	1	1	1	1	1	1	1	1	1	1	1	994 280 250		6KT-SCHRAUBE	M8x25	HEXAGONAL SCREW	VIS HEXAGONAL	TORNILLO HEXAGONAL	
7	188	1	1	1	1	1	1	1	1	1	1	1	1	1	1	1	1	1	1	1	1	1	1	1	1	1	994 280 250		6KT-SCHRAUBE	M8x25	HEXAGONAL SCREW	VIS HEXAGONAL	TORNILLO HEXAGONAL	
7	189	1	1	1	1	1	1	1	1	1	1	1	1	1	1	1	1	1	1	1	1	1	1	1	1	1	394 228 022		DISTANZHÜLSE		SPACER	DOUILLE DE DISTANCE	CASQUILLO SEPARADOR	
7	190	1	1	1	1	1	1	1	1	1	1	1	1	1	1	1	1	1	1	1	1	1	1	1	1	1	394 228 022		DISTANZHÜLSE		SPACER	DOUILLE DE DISTANCE	CASQUILLO SEPARADOR	
7	193	1	1	1	1	1	1	1	1	1	1	1	1	1	1	1	1	1	1	1	1	1	1	1	1	1	929 240 180		SICHERUNGSRING		SNAP RING	CIRCLIP	ANILLO SEGURIDAD	
7	194	1	1	1	1	1	1	1	1	1	1	1	1	1	1	1	1	1	1	1	1	1	1	1	1	1	929 240 180		SICHERUNGSRING		SNAP RING	CIRCLIP	ANILLO SEGURIDAD	
7	195					1									1												326 211 020		BUCHSE		BUSHING	DOUILLE	CASQUILLO	
7	196						1																				908 905 125		INNEN-6KT-SC HRAUBE	5x12	SCREW	VIS	TORNILLO	
7	197	1	1	1	1	1	1	1	1	1	1	1	1	1	1	1	1	1	1	1	1	1	1	1	1	1	394 213 032		SPANNSCHRAUBE		TENSIONING SCREW	VIS DE TENSION	TORNILLO DE TENSIÓN	
7	198	1	1	1	1	1	1	1	1	1	1	1	1	1	1	1	1	1	1	1	1	1	1	1	1	1	394 342 120		DRUCKFEDER		COMPRESSION SPRING	RESSORT DE PRESSION	RESORTE DE PRESIÓN	
7	199	1	1	1	1	1	1	1	1	1	1	1	1	1	1	1	1	1	1	1	1	1	1	1	1	1	921 906 004		4KT-MUTTER	M6	SQUARE NUT	ECROU CARRÉ	TUERCA CUADR.	
7	200	2	2	2	2	2	2	2	2	2	2	2	2	2	2	2	2	2	2	2	2	2	2	2	2	2	2	923 208 004		6KT-MUTTER	M8	HAXAGONAL NUT	ECROU HEXAGONAL	TUERCA HEXAGONAL
7	201	1		1				1				1															980 114 972		SICHERHEITS AUFKLEBER	ø300/20,0mm; ø12"/.787"	SAFETY LABEL	PLAQUE	CALCOMANIA	
7	201		1		1	1				1			1														980 114 975		SICHERHEITS AUFKLEBER	ø350/25,4mm; ø14"/1"	SAFETY LABEL	PLAQUE	CALCOMANIA	
7	201		1		1					1																	980 114 974		SICHERHEITS AUFKLEBER	ø350/20,0mm; ø14"/.787"	SAFETY LABEL	PLAQUE	CALCOMANIA	
7	201					1								1													980 115 226		SICHERHEITS AUFKLEBER	ø400/20,0mm; ø16"/.787"	SAFETY LABEL	PLAQUE	CALCOMANIA	
7	201	1		1																							980 115 616	RU	SICHERHEITS AUFKLEBER	ø300/20,0mm; ø12"/.787"	SAFETY LABEL	PLAQUE	CALCOMANIA	

DPC6430, DPC6431, DPC7330, DPC7331, DPC8131,
 DPC8132, DPC6440, DPC6441, DPC7340, DPC7341,
 DPC6430, DPC7331, DPC8131, DPC8132, DPC6440
 , DPC7341 , DPC6430 , DPC6431 , DPC7330 , DPC7331
 , DPC8131 , DPC8132 , DPC6440 , DPC6441 ,
 DPC7340 , DPC7341

7

Schneidvorsatz, Schutzhaube
 Cutting device, protection hood
 Dispositif de coupe, capot de protection
 Dispositivo tranzadora, cubierta protectora

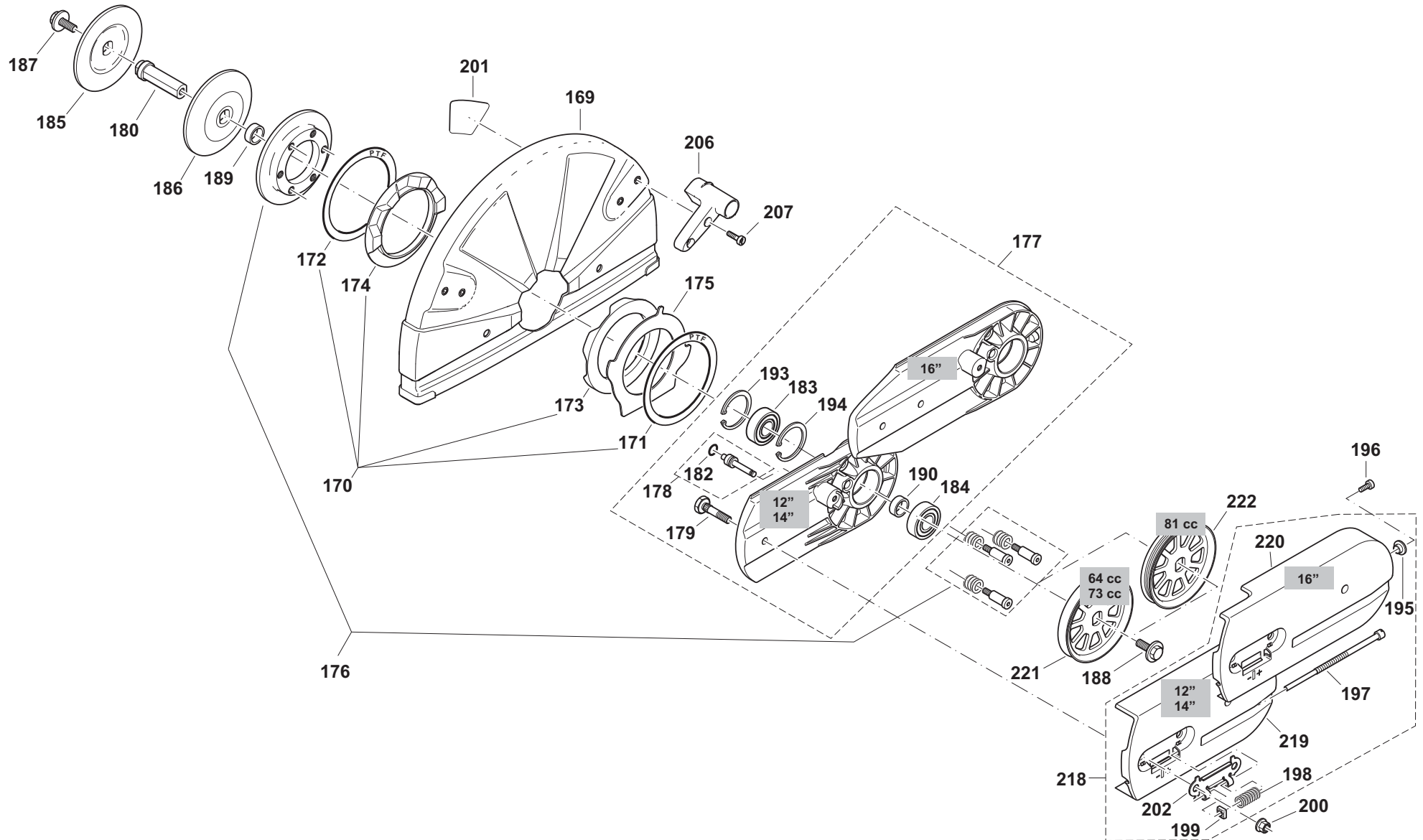

DPC6430, DPC6431, DPC7330, DPC7331, DPC8131, DPC8132, DPC6440, DPC6441, DPC7340, DPC7341, DPC6430, DPC7331, DPC8131, DPC8132, DPC6440, DPC7341, DPC6430, DPC6431, DPC7330, DPC7331, DPC8131, DPC8132, DPC6440, DPC6441, DPC7340, DPC7341

7

Schneidvorsatz, Schutzhaube
Cutting device, protection hood
Dispositif de coupe, capot de protection
Dispositivo tranzadora, cubierta protectora



Seite / Page	Pos.	DPC6430	DPC6431	DPC7330	DPC7331	DPC8131	DPC8132	DPC6440	DPC6441	DPC7340	DPC7341	DPC6430 (UK)	DPC7331 (UK)	DPC8131 (UK)	DPC8132 (UK)	DPC6440 (UK)	DPC7341 (UK)	DPC6430 (USA)	DPC6431 (USA)	DPC7330 (USA)	DPC7331 (USA)	DPC8131 (USA)	DPC8132 (USA)	DPC6440 (USA)	DPC6441 (USA)	DPC7340 (USA)	DPC7341 (USA)	Teil-Nr. Part No. No. de pièce No. de pieza	Hinweise Notes Renseign. Nota	Bezeichnung	Spezifikation Specification	Description	Désignation	Denominación
7	201	1									1																	980 115 557		SICHERHEITS AUFKLEBER	ø300/25,4mm; ø12"/1"	SAFETY LABEL	PLAQUE	CALCOMANIA
7	201		1																									980 115 615	RU	SICHERHEITS AUFKLEBER	ø350/20,0mm; ø14"/.787"	SAFETY LABEL	PLAQUE	CALCOMANIA
7	201				1																							980 115 614	RU	SICHERHEITS AUFKLEBER	ø350/25,4mm; ø14"/1"	SAFETY LABEL	PLAQUE	CALCOMANIA
7	201					1																						980 115 612	RU	SICHERHEITS AUFKLEBER	ø400/20,0mm; ø16"/.787"	SAFETY LABEL	PLAQUE	CALCOMANIA
7	202	1	1	1	1	1	1	1	1	1	1	1	1	1	1	1	1	1	1	1	1	1	1	1	1	1	1	394 213 021		AUFNAHMEBL ECH		METAL SHEET	TÔLE	CHAPA
7	206	1	1	1	1	1	1	1	1	1	1	1	1	1	1	1	1	1	1	1	1	1	1	1	1	1	1	326 341 301		GRIF SCHUTZHAUB E		GRIP FOR PROTECTIV E HOOD	POIGNÉE POUR CAPOT DE PROTECT.	ASA PARA LA CAPOTA DE PROTECC.
7	207	2	2	2	2	2	2	2	2	2	2	2	2	2	2	2	2	2	2	2	2	2	2	2	2	2	2	908 605 165		INNENSTERN- SCHLITZ-SCHR AUBE	M5x16	SCREW	VIS	TORNILLO
7	218	1	1	1	1			1	1	1	1	1	1	1		1	1	1	1	1	1		1	1	1	1	1	395 211 640	2010 =>	ABDECKUNG SCHNEIDVORS . KPL., BLAU	12", 14", blue, highly polishedINC. 195,197-199,202,219	COVER CPL.	COUVERCLE CPL.	CUBIERTA CPL.
7	218					1								1									1					395 211 650	2010 =>	ABDECKUNG SCHNEIDVORS . KPL., BLAU	16", blue, highly polishedINC. 195,197-199,202,220	COVER CPL.	COUVERCLE CPL.	CUBIERTA CPL.
7	219	1	1	1	1			1	1	1	1	1	1	1		1	1	1	1	1	1		1	1	1	1	1	395 211 620	2010 =>	ABDECKUNG SCHNEIDVORS , BLAU	12", 14", blue, highly polished	COVER	COUVERCLE	CUBIERTA
7	220					1								1									1					395 211 630	2010 =>	ABDECKUNG SCHNEIDVORS , BLAU	16", blue, highly polished	COVER	COUVERCLE	CUBIERTA
7	221	1	1	1	1			1	1	1	1	1	1		1	1	1	1	1	1			1	1	1	1	1	394 221 050		KEILRIEMENS CHEIBE		BELT PULLEY	POULIE	POLEA
7	222				1	1								1	1													326 221 020		KEILRIPPENS HEIBE		BELT PULLEY	POULIE	POLEA

DPC6430, DPC6431, DPC7330, DPC7331, DPC8131,
DPC8132, DPC6440, DPC6441, DPC7340, DPC7341,
DPC6430, DPC7331, DPC8131, DPC8132, DPC6440
, DPC7341, DPC6430, DPC6431, DPC7330, DPC7331
, DPC8131, DPC8132, DPC6440, DPC6441,
DPC7340, DPC7341

8

Trennscheiben, Werkzeug
Blades, tools
Disques, outils
Discos para dividir, herramientas

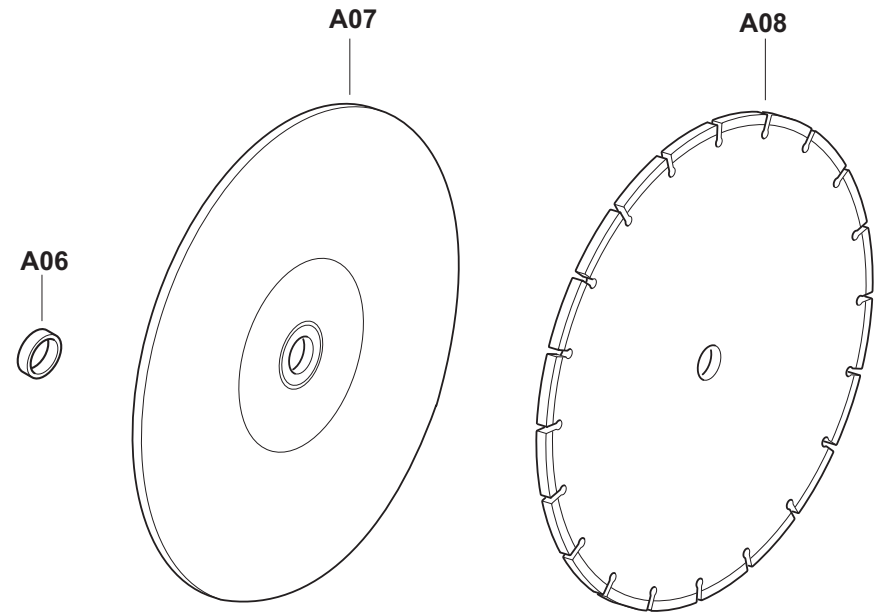
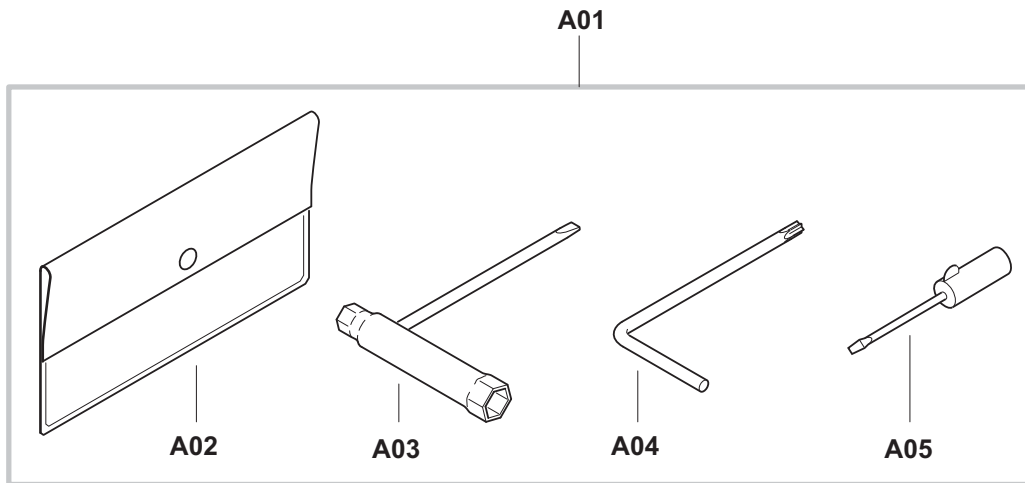

DPC6430, DPC6431, DPC7330, DPC7331, DPC8131, DPC8132, DPC6440, DPC6441, DPC7340, DPC7341, DPC6430, DPC7331, DPC8131, DPC8132, DPC6440, DPC7341, DPC6430, DPC6431, DPC7330, DPC7331, DPC8131, DPC8132, DPC6440, DPC6441, DPC7340, DPC7341

8

Trennscheiben, Werkzeug
Blades, tools
Disques, outils
Discos para dividir, herramientas



Seite / Page	Pos.	DPC6430	DPC6431	DPC7330	DPC7331	DPC8131	DPC8132	DPC6440	DPC6441	DPC7340	DPC7341	DPC6430 (UK)	DPC7331 (UK)	DPC8131 (UK)	DPC8132 (UK)	DPC6440 (UK)	DPC7341 (UK)	DPC6430 (USA)	DPC6431 (USA)	DPC7330 (USA)	DPC7331 (USA)	DPC8131 (USA)	DPC8132 (USA)	DPC6440 (USA)	DPC6441 (USA)	DPC7340 (USA)	DPC7341 (USA)	Teil-Nr. Part No. No. de pièce No. de pieza	Hinweise Notes Renseign. Nota	Bezeichnung	Spezifikation Specification	Description	Désignation	Denominación
8	A01	1	1	1	1	1	1	1	1	1	1	1	1	1	1	1	1	1	1	1	1	1	1	1	1	1	1	957 004 006		WERKZEUG KPL.	INC. A02-A05	TOOLS CPL.	OUTILS CPL.	HERRAMIENTAS CPL.
8	A02	1	1	1	1	1	1	1	1	1	1	1	1	1	1	1	1	1	1	1	1	1	1	1	1	1	1	950 004 002		WERKZEUGTASCHE		PLASTIK BAG	POCHETTE EN PLASTIQUE	CÁRTERA HERRAMIENTAS
8	A03	1	1	1	1	1	1	1	1	1	1	1	1	1	1	1	1	1	1	1	1	1	1	1	1	1	1	941 719 140		KOMBISCHLÜSSEL	SW 13/19 mm	UNIVERSAL WRENCH	CLÉ COMBINÉE	LLAVE DE BUJIA
8	A04	1	1	1	1	1	1	1	1	1	1	1	1	1	1	1	1	1	1	1	1	1	1	1	1	1	1	940 827 000		WINKELSCHRAUBENDREHER	T27	ANGLED SCREW DRIVER	CLÉ ANGLE	LLAVE ANGULAR
8	A05	1	1	1	1	1	1	1	1	1	1	1	1	1	1	1	1	1	1	1	1	1	1	1	1	1	1	944 340 001		SCHRAUBENDREHER		SCREWDRIVER	TOURNEVIS	DESTORNILLADOR
8	A06	1	1	1	1	1	1	1	1	1	1	1	1	1	1	1	1	1	1	1	1	1	1	1	1	1	1	394 228 121	Acc.	ADAPTERRING	ø 20/25,4 mm	ADAPTER	ADAPTATEUR	ADAPTOR
8	A07	1		1				1		1		1			1		1		1					1		1	966 121 150		TRENNSCHEIBE HARZ, STAHL	300/20mm; 12"	ABRAS. BLADE, STEEL	DISQUE SYNTH. ACIER	DISCO SINT. ACERO	
8	A07	1		1				1		1		1			1		1		1					1		1	966 121 120		TRENNSCHEIBE HARZ, STEIN	300/20mm; 12"	ABRAS. BLADE, STONE	DISQUE SYNTH. BÉTON	DISCO SINT. PEDRA	
8	A07		1		1			1		1		1			1		1		1					1		1	966 144 120		TRENNSCHEIBE HARZ, STEIN	350/25,4mm; 14"	ABRAS. BLADE, STONE	DISQUE SYNTH. BÉTON	DISCO SINT. PEDRA	
8	A07		1		1			1		1		1			1		1		1					1		1	966 144 150		TRENNSCHEIBE HARZ, STAHL	350/25,4mm; 14"	ABRAS. BLADE, STEEL	DISQUE SYNTH. ACIER	DISCO SINT. ACERO	
8	A07		1		1			1		1		1			1		1		1					1		1	966 141 150		TRENNSCHEIBE HARZ, STAHL	350/20mm; 14"	ABRAS. BLADE, STEEL	DISQUE SYNTH. ACIER	DISCO SINT. ACERO	
8	A07		1		1			1		1		1			1		1		1					1		1	966 141 120		TRENNSCHEIBE HARZ, STEIN	350/20mm; 14"	ABRAS. BLADE, STONE	DISQUE SYNTH. BÉTON	DISCO SINT. PEDRA	
8	A07				1	1							1	1								1	1					966 164 050		TRENNSCHEIBE HARZ, STAHL	400/1"; 16"	ABRAS. BLADE, STEEL	DISQUE SYNTH. ACIER	DISCO SINT. ACERO
8	A07				1	1							1	1								1	1					966 161 020		TRENNSCHEIBE HARZ, STEIN	400/20mm; 16"	ABRAS. BLADE, STONE	DISQUE SYNTH. BÉTON	DISCO SINT. PEDRA
8	A07				1	1							1	1								1	1					966 161 050		TRENNSCHEIBE HARZ, STAHL	400/20mm; 16"	ABRAS. BLADE, STEEL	DISQUE SYNTH. ACIER	DISCO SINT. ACERO
8	A08	1		1				1		1		1			1		1		1				1		1				Acc.	TRENNSCHEIBE DIAMANT	ø 300mm/12"	DIAMOND BLADE	DISQUE DIAMANT	DISCO DIAMANTE
8	A08		1		1			1		1		1			1		1		1				1		1				Acc.	TRENNSCHEIBE DIAMANT	ø 350mm/14"	DIAMOND BLADE	DISQUE DIAMANT	DISCO DIAMANTE
8	A08				1	1							1	1								1	1						Acc.	TRENNSCHEIBE DIAMANT	ø 400mm/16"	DIAMOND BLADE	DISQUE DIAMANT	DISCO DIAMANTE

DPC6430, DPC6431, DPC7330, DPC7331, DPC8131,
DPC8132, DPC6440, DPC6441, DPC7340, DPC7341,
DPC6430, DPC7331, DPC8131, DPC8132, DPC6440
, DPC7341, DPC6430, DPC6431, DPC7330, DPC7331
, DPC8131, DPC8132, DPC6440, DPC6441,
DPC7340, DPC7341

9

Wasseranschluß, Druckwassertank • Nicht im Lieferumfang
Water attachment, pressurised water tank • Not included in delivery
Raccordement d'eau, réservoir d'eau sous pres. • Non incl. dans la livraison
Acometida de agua, tanque de agua a pres. • No incluidos en entrega

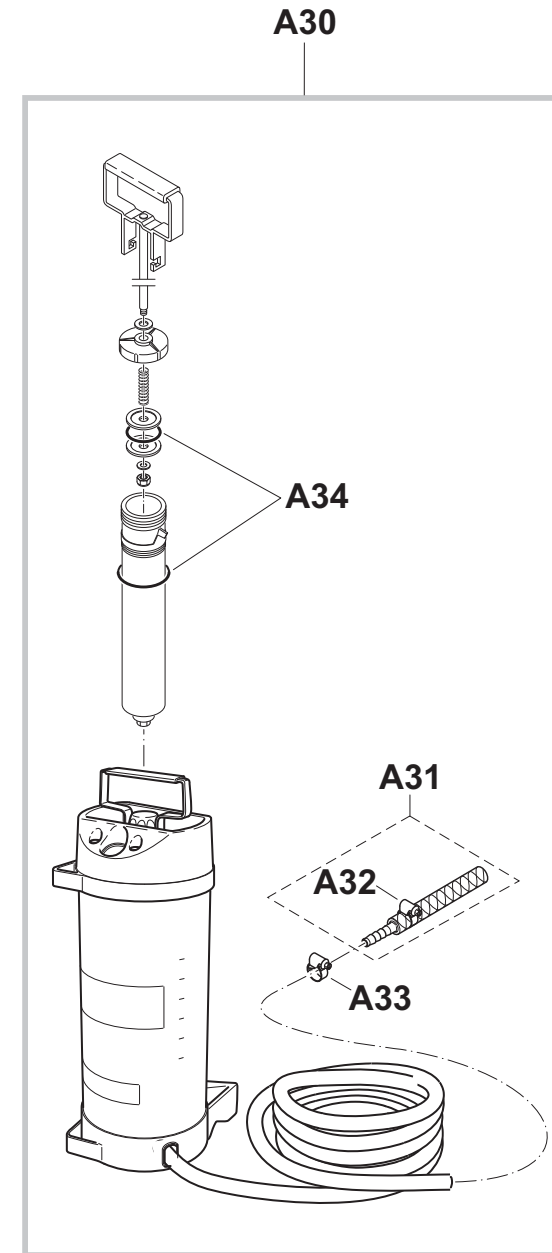
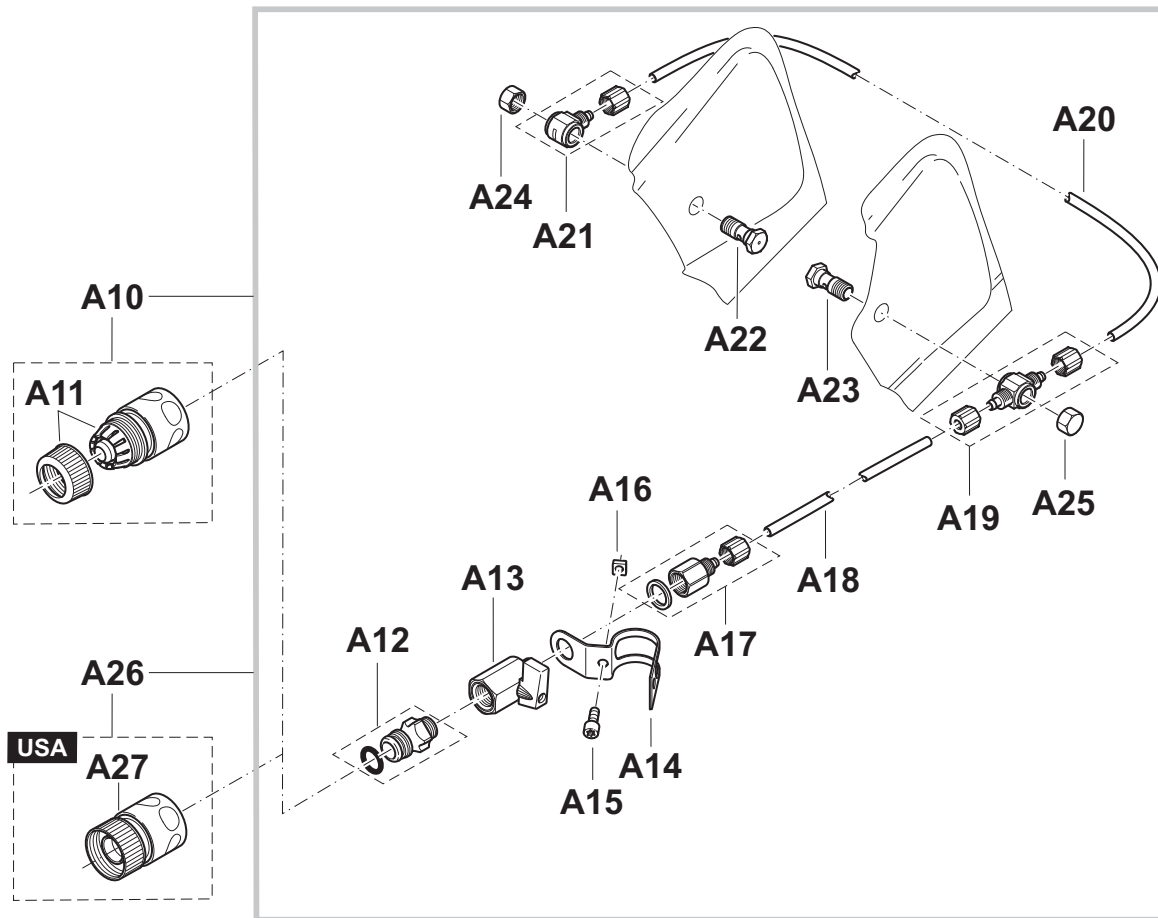

DPC6430, DPC6431, DPC7330, DPC7331, DPC8131, DPC8132, DPC6440, DPC8441, DPC7340, DPC7341, DPC6430, DPC7331, DPC8131, DPC8132, DPC6440, DPC7341, DPC6430, DPC6431, DPC7330, DPC7331, DPC8131, DPC8132, DPC6440, DPC8441, DPC7340, DPC7341

9

Wasseranschluß, Druckwassertank • Nicht im Lieferumfang
 Water attachment, pressurised water tank • Not included in delivery
 Raccordement d'eau, réservoir d'eau sous pres. • Non incl. dans la livraison
 Acometida de agua, tanque de agua a pres. • No incluidos en entrega



Seite / Page	Pos.	DPC6430	DPC6431	DPC7330	DPC7331	DPC8131	DPC8132	DPC6440	DPC6441	DPC7340	DPC7341	DPC6430 (UK)	DPC7331 (UK)	DPC8131 (UK)	DPC8132 (UK)	DPC6440 (UK)	DPC7341 (UK)	DPC6430 (USA)	DPC6431 (USA)	DPC7330 (USA)	DPC7331 (USA)	DPC8131 (USA)	DPC8132 (USA)	DPC6440 (USA)	DPC6441 (USA)	DPC7340 (USA)	DPC7341 (USA)	Teil-Nr. Part No. No. de pièce No. de pieza	Hinweise Notes Renseign. Nota	Bezeichnung	Spezifikation Specification	Description	Désignation	Denominación
9	A10	1	1	1	1	1	1	1	1	1	1	1	1	1	1	1	1											394 365 102		DRUCK-, FALLWASSERAR MATUR	INC. A11-A25	WATER ATTACHMENT KIT	JEU DE RACCORDEMENT D'EAU	ACOMETIDA DE AGUA
9	A11	1	1	1	1	1	1	1	1	1	1	1	1	1	1	1	1											964 802 271		SCHLAUCHKUPPL UNG	STOP	COUPLING SLEEVE	MANCHON D'ACCOUPLEME NT	ACOPLAMIENT O P. TUBOS
9	A12	1	1	1	1	1	1	1	1	1	1	1	1	1	1	1	1	1	1	1	1	1	1	1	1	1	1	964 802 282		EINSCHRAUBNIP PEL		HOSE CONNECTOR	RACCORD POUR TUYAU	BOQUILLA ROSCADA
9	A13	1	1	1	1	1	1	1	1	1	1	1	1	1	1	1	1	1	1	1	1	1	1	1	1	1	1	964 802 291		KUGELVENTIL		SHUT OFF COCK	ROBINET D'ARRÊT	LLAVE DE PASO
9	A14	1	1	1	1	1	1	1	1	1	1	1	1	1	1	1	1	1	1	1	1	1	1	1	1	1	1	394 365 163		SCHELLE		CLAMP	BRIDE DE FIXATION	ABRAZADERA
9	A15	1	1	1	1	1	1	1	1	1	1	1	1	1	1	1	1	1	1	1	1	1	1	1	1	1	1	909 006 145		SCHRAUBE	M6x14	SCREW	VIS	TORNILLO
9	A16	1	1	1	1	1	1	1	1	1	1	1	1	1	1	1	1	1	1	1	1	1	1	1	1	1	1	921 906 004		4KT-MUTTER	M6	SQUARE NUT	ECROU CARRÉ	TUERCA CUADR.
9	A17	1	1	1	1	1	1	1	1	1	1	1	1	1	1	1	1	1	1	1	1	1	1	1	1	1	1	964 802 410		SCHNELLVERSCH RAUBUNG		CONNECTING PIECE	PIÈCE DE RACCORD	PIEZA DE UNIÓN
9	A18	m	m	m	m	m	m	m	m	m	m	m	m	m	m	m	m	m	m	m	m	m	m	m	m	m	m	964 802 322		PU-SCHLAUCH	405mm; 16"	HOSE	TUYAU	TUBO
9	A19	1	1	1	1	1	1	1	1	1	1	1	1	1	1	1	1	1	1	1	1	1	1	1	1	1	1	964 802 332		SCHNELLVERSCH RAUBUNG	T	CONNECTING PIECE	PIÈCE DE RACCORD	PIEZA DE UNIÓN
9	A20	m	m	m	m	m	m	m	m	m	m	m	m	m	m	m	m	m	m	m	m	m	m	m	m	m	m	964 802 322		PU-SCHLAUCH	180mm; 7"	HOSE	TUYAU	TUBO
9	A20	m	m	m	m	m	m	m	m	m	m	m	m	m	m	m	m	m	m	m	m	m	m	m	m	m	m	964 802 322		PU-SCHLAUCH	210mm; 8 1/4"	HOSE	TUYAU	TUBO
9	A21	1	1	1	1	1	1	1	1	1	1	1	1	1	1	1	1	1	1	1	1	1	1	1	1	1	1	964 802 342		SCHNELLVERSCH RAUBUNG	L	CONNECTING PIECE	PIÈCE DE RACCORD	PIEZA DE UNIÓN
9	A22	1	1	1	1	1	1	1	1	1	1	1	1	1	1	1	1	1	1	1	1	1	1	1	1	1	1	964 802 352		HOHLSCHRAUBE GEOHRT		HOLLOW SCREW, BORED	VIS	TORNILLO
9	A23	1	1	1	1	1	1	1	1	1	1	1	1	1	1	1	1	1	1	1	1	1	1	1	1	1	1	964 802 352		HOHLSCHRAUBE GEOHRT		HOLLOW SCREW, BORED	VIS	TORNILLO
9	A24	1	1	1	1	1	1	1	1	1	1	1	1	1	1	1	1	1	1	1	1	1	1	1	1	1	1	964 802 362		HUTMUTTER		CAP NUT	ÉCROU BORGNE	TUERCA
9	A25	1	1	1	1	1	1	1	1	1	1	1	1	1	1	1	1	1	1	1	1	1	1	1	1	1	1	964 802 362		HUTMUTTER		CAP NUT	ÉCROU BORGNE	TUERCA
9	A26																	1	1	1	1	1	1	1	1	1	1	394 365 630	U.S.A.	DRUCK-, FALLWASSERAR MATUR	INC. A12-A25,A27	WATER ATTACHMENT KIT	JEU DE RACCORDEMENT D'EAU	ACOMETIDA DE AGUA
9	A27																	1	1	1	1	1	1	1	1	1	1	964 802 400	U.S.A.	SCHLAUCHKUPPL UNG	STOP 1 1/16"	COUPLING SLEEVE	MANCHON D'ACCOUPLEME NT	ACOPLAMIENT O P. TUBOS
9	A30	1	1	1	1	1	1	1	1	1	1	1	1	1	1	1	1	1	1	1	1	1	1	1	1	1	1	957 802 600		DRUCKWASSERT ANK	10 IINC. A31-A34	PRESSURISED WATER TANK	RÉSERVOIR D'EAU SOUS PRES.	TANQUE DE AGUA A PRES.

DPC6430, DPC6431, DPC7330, DPC7331, DPC8131,
DPC8132, DPC6440, DPC6441, DPC7340, DPC7341,
DPC6430, DPC7331, DPC8131, DPC8132, DPC6440
, DPC7341, DPC6430, DPC6431, DPC7330, DPC7331
, DPC8131, DPC8132, DPC6440, DPC6441,
DPC7340, DPC7341

9

Wasseranschluß, Druckwassertank • Nicht im Lieferumfang
Water attachment, pressurised water tank • Not included in delivery
Raccordement d'eau, réservoir d'eau sous pres. • Non incl. dans la livraison
Acometida de agua, tanque de agua a pres. • No incluidos en entrega

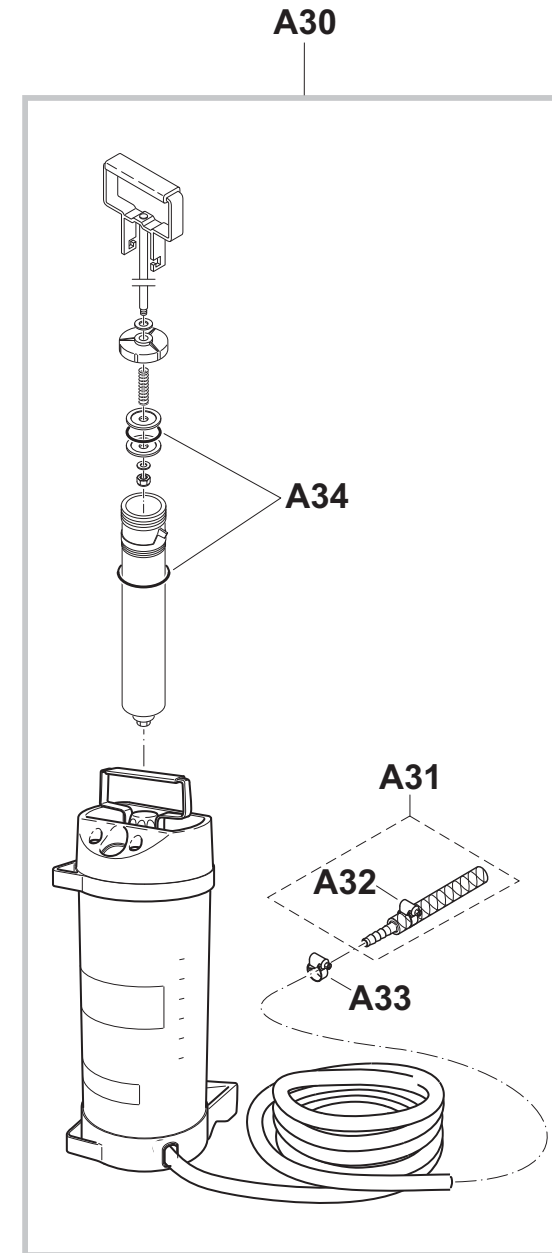
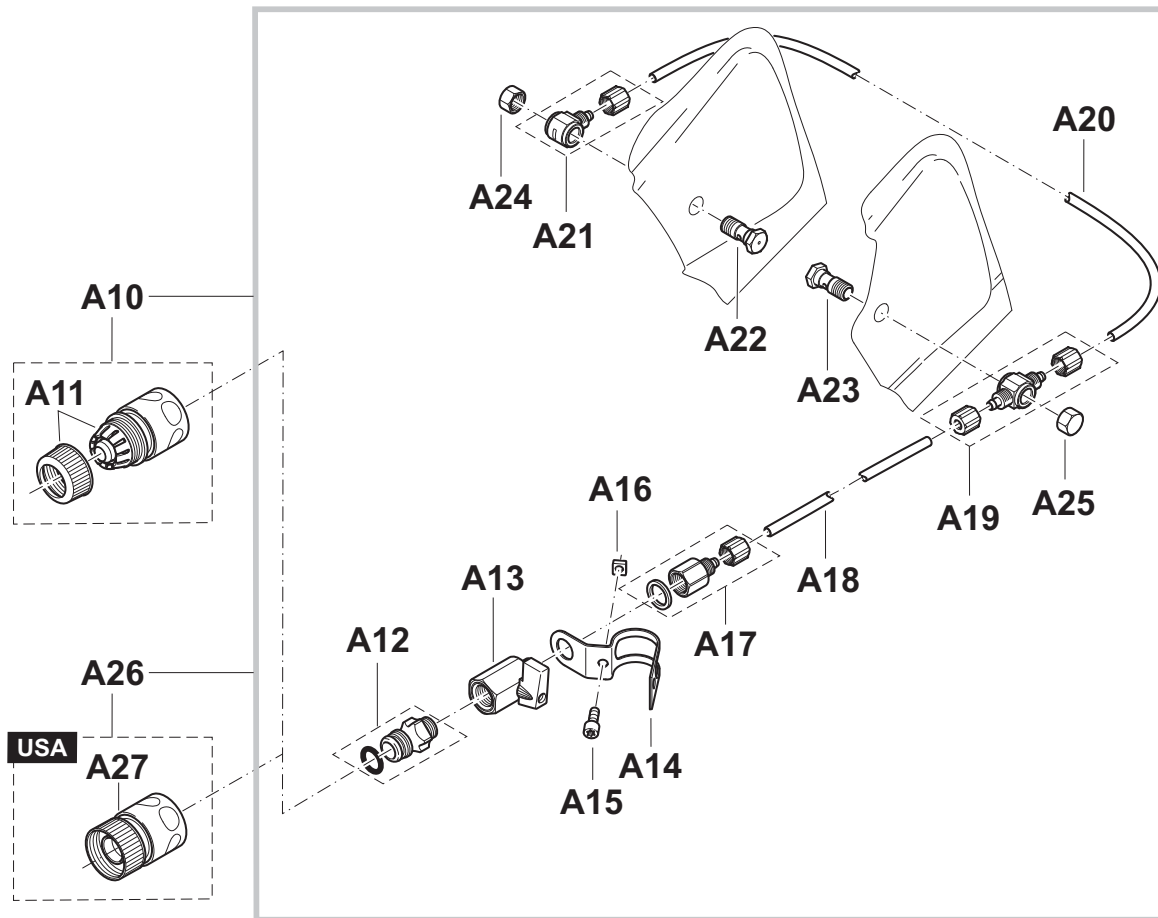

DPC6430, DPC6431, DPC7330, DPC7331, DPC8131,
 DPC8132, DPC6440, DPC6441, DPC7340, DPC7341,
 DPC6430, DPC7331, DPC8131, DPC8132, DPC6440
 , DPC7341, DPC6430, DPC6431, DPC7330, DPC7331
 , DPC8131, DPC8132, DPC6440, DPC6441,
 DPC7340, DPC7341

9

Wasseranschluß, Druckwassertank • Nicht im Lieferumfang
 Water attachment, pressurised water tank • Not included in delivery
 Raccordement d'eau, réservoir d'eau sous pres. • Non incl. dans la livraison
 Acometida de agua, tanque de agua a pres. • No incluidos en entrega



Seite / Page	Pos.	DPC6430	DPC6431	DPC7330	DPC7331	DPC8131	DPC8132	DPC6440	DPC6441	DPC7340	DPC7341	DPC6430 (UK)	DPC7331 (UK)	DPC8131 (UK)	DPC8132 (UK)	DPC6440 (UK)	DPC7341 (UK)	DPC6430 (USA)	DPC6431 (USA)	DPC7330 (USA)	DPC7331 (USA)	DPC8131 (USA)	DPC8132 (USA)	DPC6440 (USA)	DPC6441 (USA)	DPC7340 (USA)	DPC7341 (USA)	Teil-Nr. Part No. No. de pièce No. de pieza	Hinweise Notes Renseign. Nota	Bezeichnung	Spezifikation Specification	Description	Désignation	Denominación
9	A31	1	1	1	1	1	1	1	1	1	1	1	1	1	1	1	1	1	1	1	1	1	1	1	1	1	1	394 365 180		SCHLAUCHADAPTER		CONNECTING REDUCER	RACCORD RÉDUCTEUR	REDUCTOR
9	A32	1	1	1	1	1	1	1	1	1	1	1	1	1	1	1	1	1	1	1	1	1	1	1	1	1	964 802 250		SCHLAUCHSCHELLE	ø10-16 mm	HOSE CLIP	COLLIER DE SERRAGE	ABRAZADERA	
9	A33	1	1	1	1	1	1	1	1	1	1	1	1	1	1	1	1	1	1	1	1	1	1	1	1	1	964 802 250		SCHLAUCHSCHELLE	ø10-16 mm	HOSE CLIP	COLLIER DE SERRAGE	ABRAZADERA	
9	A34	1	1	1	1	1	1	1	1	1	1	1	1	1	1	1	1	1	1	1	1	1	1	1	1	1	957 963 200		DICHTUNGSSATZ		GASKET SET	JEU DE JOINTS	JUEGO JUNTAS	

DPC6430, DPC6431, DPC7330, DPC7331, DPC8131,
 DPC8132, DPC6440, DPC6441, DPC7340, DPC7341,
 DPC6430, DPC7331, DPC8131, DPC8132, DPC6440
 , DPC7341, DPC6430, DPC6431, DPC7330, DPC7331
 , DPC8131, DPC8132, DPC6440, DPC6441,
 DPC7340, DPC7341



	Zeichenerklärung	Key to symbols	Légende	Explicación de símbolos
=> 1999999 2000000 => 2003.04 => TI 2003/07 Acc. = { m Corr.	Produktion bis Serien-Nr. Neues Teil ab Serien-Nr. Neues Teil ab Jahr / Monat Siehe Technische Information Jahr / Nr. Zubehör (nicht im Lieferumfang) Keine Serienausführung, jedoch verwendbar Beinhaltet Positions-Nr. Meterware Druckfehlerberichtigung	Production to serial number New part from serial number New part from Year / Month See Technical Information Year / No. Accessories (not included in the delivery inventory) No standard execution, may be used Contains item number Sold by the meter Error correction	Production jusqu'à n° de série Nouveau pièce à partir du n° de série Nouveau pièce à partir de année / mois Voir information technique année / n° Accessoires (non compris dans la livraison) Aucune exécut. en série, cependant utilisable contient n° de numéro Au mètre Rectification d'erreurs	Producción hasta N° de serie Pieza nueva a partir de N° de serie Pieza nueva a partir de año / mes Véase inform. técnico año / N° Accesorios (no incluido en la extensión del suministro) No es de serie, pero sirve Contiene pos N° Por metro Fe de erratas
	Änderungen vorbehalten	Specifications subject to change without notice	Changements sans préavis	Mejoras constructivas sin previo aviso