

RYOBI 10 in. DRILL PRESS – MODEL NUMBER DP101

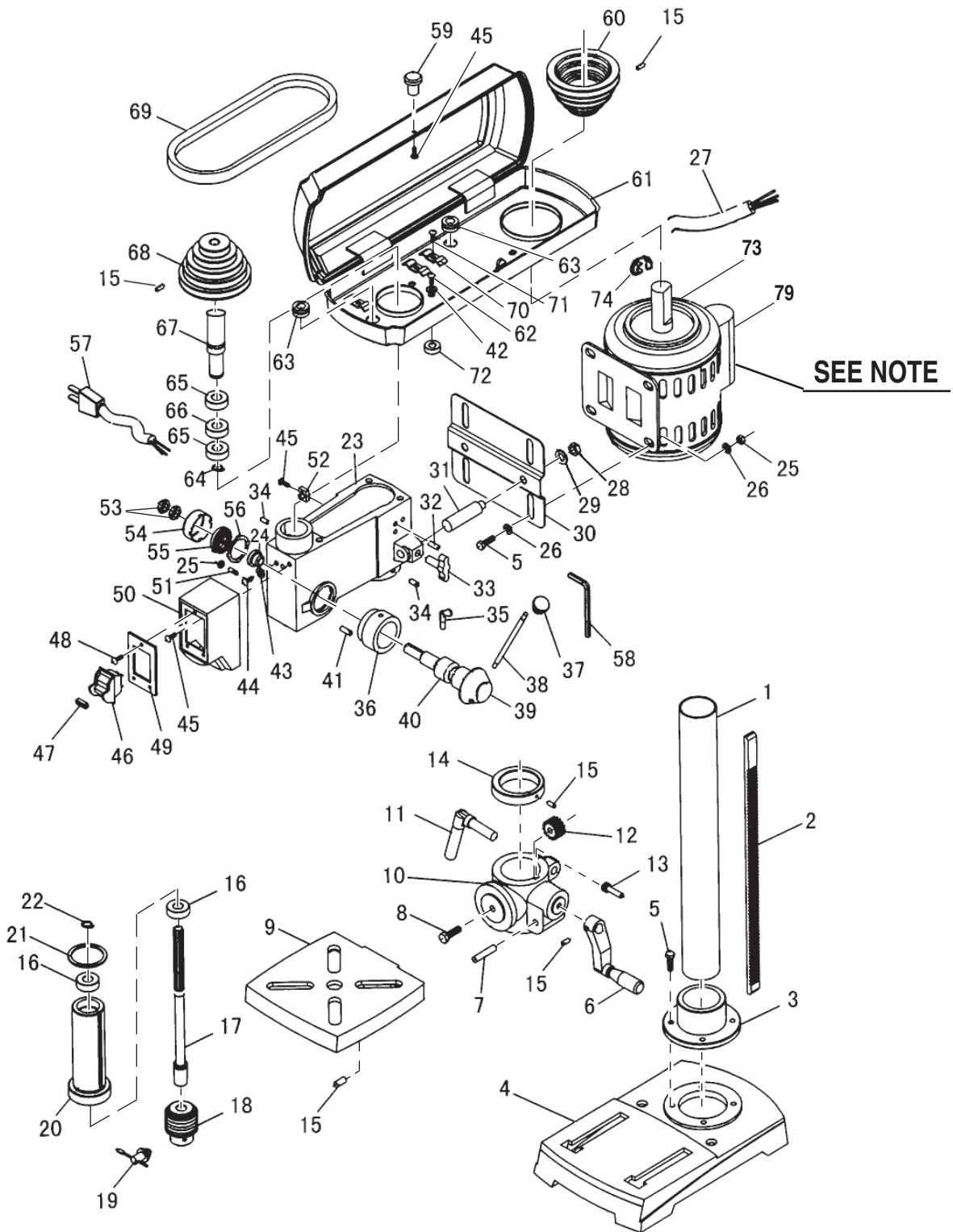

**NOTE:** The assembly shown represents an important part of the double insulated system. To avoid the possibility of alteration or damage to the system, service should be performed by your nearest Ryobi Authorized Service Center. For the service center nearest you call 1-800-525-2579.

## RYOBI 10 in. DRILL PRESS – MODEL NUMBER DP101

The model number will be found on a plate attached to the motor housing. Always mention the model number in all correspondence regarding your **DRILL PRESS** or when ordering repair parts.

### PARTS LIST

Key Part No. Number	Description	Qty.	Key Part No. Number	Description	Qty.		
1	13201003	COLUMN TUBE.....	1	42	TDP07003	WASHER (M6).....	4
2	13201010	RACK.....	1	43	TDP08001	TOOTHED LOCK WASHER (M5)....	2
3	13201002	BASE COLLAR.....	1	44	TDP07001	SCREW (M5 X 6 mm).....	2
4	13201001A	BASE.....	1	45	TDP07002	SCREW (M5 X 14 mm).....	2
5	TDP01001	HEX SCREW (M8 X 20 mm).....	4	46	16102010B	SWITCH.....	1
6	089140200701	TABLE CRANK HANDLE ASSY....	1	47	16102010B1	SWITCH KEY.....	1
7	13201007	GEAR SHAFT.....	1	48	TDP07005	PAN HD TAPPING SCREW.....	3
8	TDP05001	HEX SCREW (M12 X 25 mm).....	1	49	13102009Q	SWITCH PLATE.....	1
9	13201014D	TABLE.....	1	50	13202008B	SWITCH BOX.....	1
10	13201004	TABLE SUPPORT W/SCALE.....	1	51	13202021	SPECIAL SET SCREW.....	1
11	16101013A	TABLE LOCK HANDLE.....	1	52	16103011A	CHUCK KEY HOLDER.....	1
12	13201006	GEAR.....	1	53	TDP06003	HEX NUT (M12 X 1.75 mm).....	2
13	13201008	WORM GEAR.....	1	54	13104008	SPRING CAP.....	1
14	13201011C	COLUMN COLLAR.....	1	55	13104009	TORSION SPRING.....	1
15	TDP03001	SET SCREW (M8 X 10 mm).....	3	56	13104007	SPRING RETAINER.....	1
16	TDP02001	BALL BEARING (60201).....	2	57	13302015E2	POWER CORD.....	1
17	13203001A	SPINDLE SHAFT.....	1	58	TDP04001	HEX KEY (4 mm).....	1
18	13103006M	CHUCK.....	1	59	16105008	PULLEY HOUSING KNOB.....	1
19	13103006M1	CHUCK KEY.....	1	60	13205005	MOTOR PULLEY.....	1
20	13203002D	QUILL TUBE.....	1	61	13205000H	PULLEY HOUSING.....	1
21	13303006	QUILL GASKET.....	1	62	TDP07003	SCREW (M6 X 8 mm).....	4
22	TDP10001	RETAINING RING.....	11	63	20105012	RUBBER BUSHING.....	2
23	13202001G	HEAD.....	1	64	TDP10002	RETAINING RING.....	1
24	13204006	SHAFT SUPPORT.....	1	65	TDP02001	BALL BEARING (60201).....	2
25	TDP06001	HEX NUT (M8).....	4	66	13302023A	SPACER.....	1
26	TDP11002	WASHER (M8).....	8	67	13202022	PULLEY INSERT.....	1
27	13202016	MOTOR CORD.....	1	68	13205006	SPINDLE PULLEY.....	1
28	TDP06002	HEX NUT (M10).....	2	69	13205007	BELT (K31).....	1
29	TDP11001	LOCK WASHER (M10).....	2	70	13202014A	CORD CLAMP W/SLEEVE.....	3
30	13202007	MOTOR BRACKET.....	1	71	TDP07004	SCREW (M5 X 10 mm).....	3
31	13202002	MOTOR SUPPORT.....	2	72	13105009	FOAM WASHER.....	4
32	TDP09001	ROLL PIN (M6 X 16 mm).....	2	73	YYG71L404	MOTOR W/CORD & RELIEF.....	1
33	13102005B	BELT TENSION KNOB.....	2	74	TDP12001	BEND RELIEF.....	1
34	TDP03002	HEX SCREW (M8 X 8 mm).....	2	75	13206006E	LOGO PLATE.....	1
35	16104012	SCALE SET HANDLE.....	1	76	13206007K	WARNING LABEL.....	1
36	13304003	DEPTH STOP RING W/SCALE....	1	77	13206008C	DATA PLATE.....	1
37	13304011C	KNOB.....	3	78	13206009A	SPEED CHART LABEL.....	1
38	13204005A	FEED HANDLE.....	3	79	089140200094	CAPACITOR (DP101 MOTOR).....	1
39	13304001	HUB.....	1		972000909	OPERATOR'S MANUAL	
40	13204002B	PINNION SHAFT.....	1		972000909R	REPAIR SHEET (REV:01)	
41	16104010	STOP PIN.....	1		06-28-06		

\* Standard Hardware Item — May Be Purchased Locally