

DM 330

Reservdelar

Spare parts

Ersatzteile

Pieces de rechange

Piezas de repuesto

Ricambi

Peças sobresselente

A1 DM330

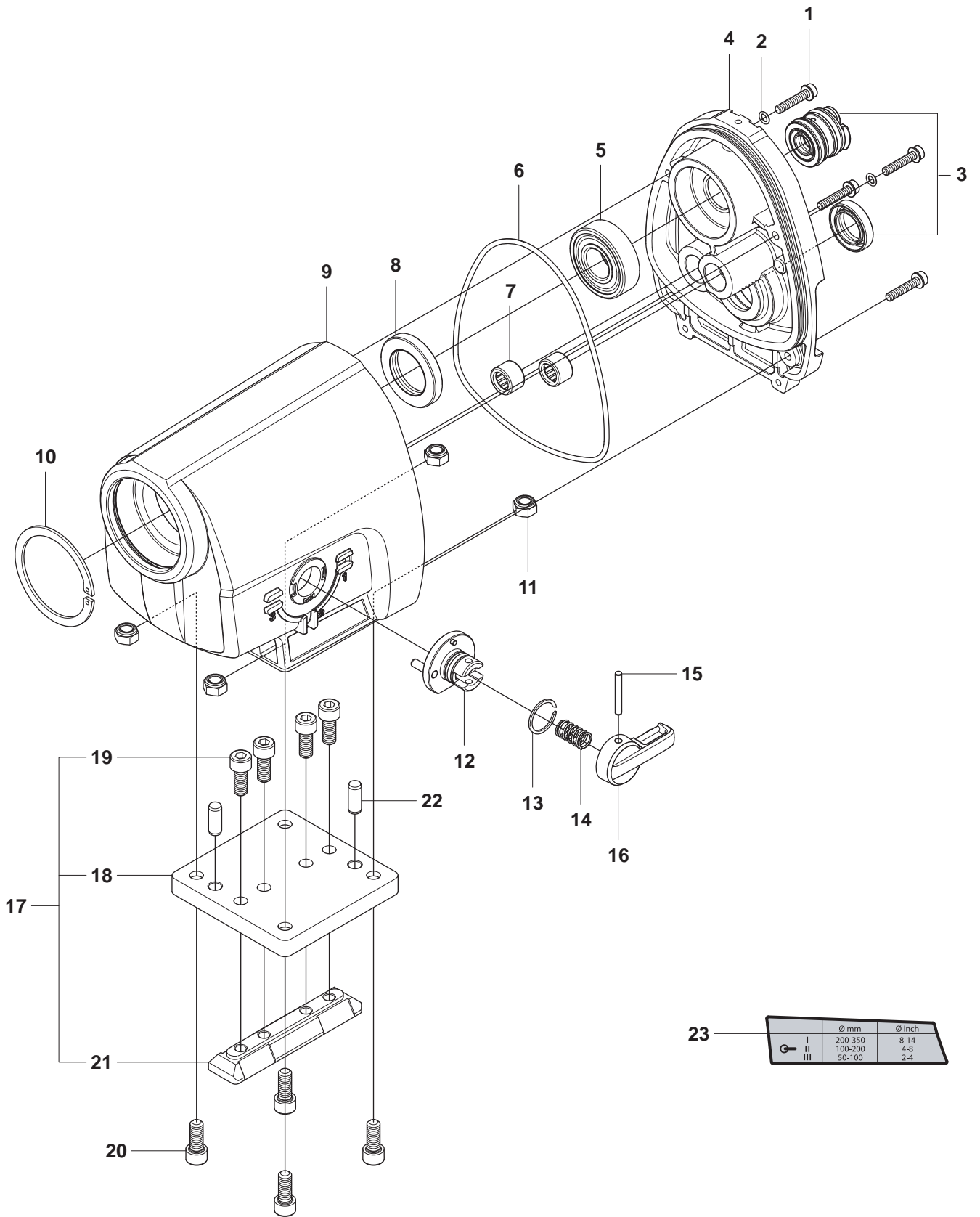

23

	Ø mm	Ø inch
I	200-350	8-14
II	100-200	4-8
III	50-100	2-4

Page A1
DM330

Pos.	Part No.	Description	Quantity	Notes
1	503 20 74-25	SCREW	4	
2	740 42 03-00	O-RING	2	
3	525 82 58-01	SEAL KIT	1	
4	544 40 23-02	COVER	1	
5	738 22 04-19	BALL BEARING	1	
6	502 49 65-02	O-RING	1	
7	503 25 53-01	NEEDLE BEARING	2	
8	502 49 63-02	SEALING RING	1	
9	544 40 22-01	GEAR HOUSING	1	
10	502 49 70-01	CIRCLIP	1	
11	732 25 18-01	LOCK NUT	4	
12	502 47 97-01	SHAFT	1	
13	735 31 22-41	CIRCLIP	1	
14	502 49 61-01	COMPRESSION SPRING	1	
15	720 12 76-06	PARALLEL PIN	1	
16	544 44 81-01	GEAR SHIFT LEVER	1	
17	544 80 64-01	MOTOR BRACKET	1	Incl. 18, 19 and 21
18	544 80 67-01	PLATE	1	
19	725 54 51-01	SCREW	4	
20	725 54 51-01	SCREW	4	
21	544 80 66-01	WEDGE	1	
22	720 14 01-06	PARALLEL PIN	2	
23A	505 42 98-01	LABEL	1	Low speed version
23B	505 40 60-01	LABEL	1	High speed version

A2 DM330

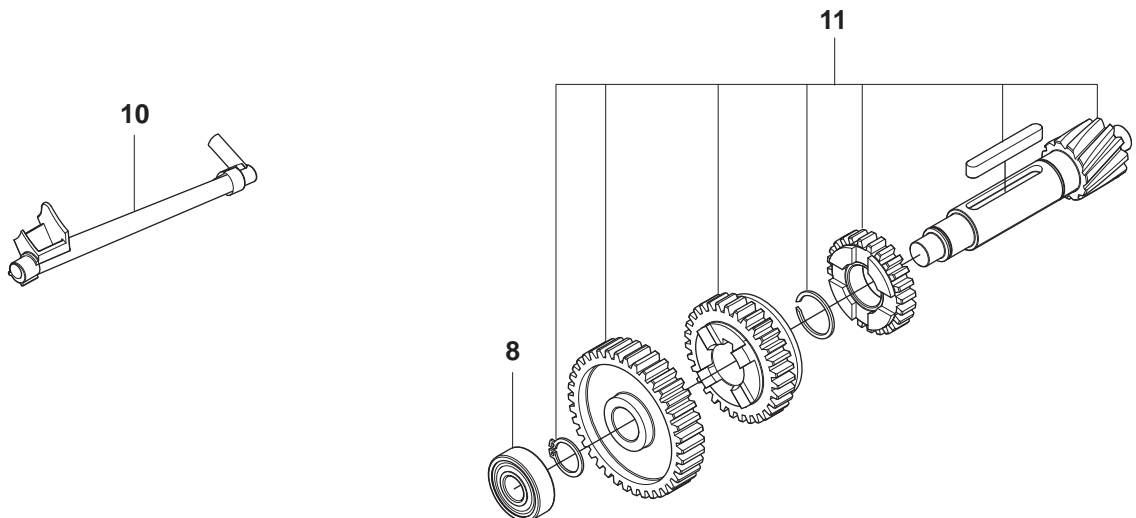
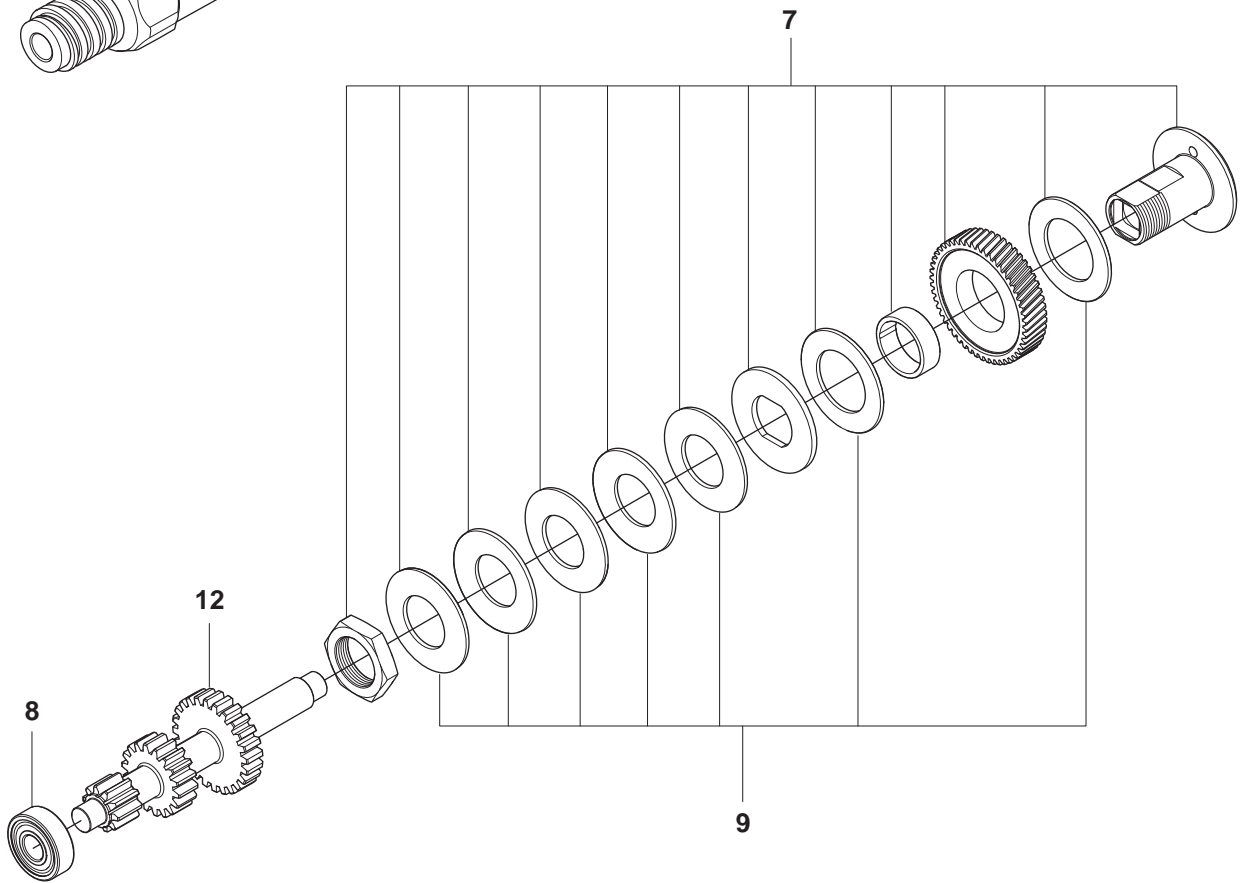
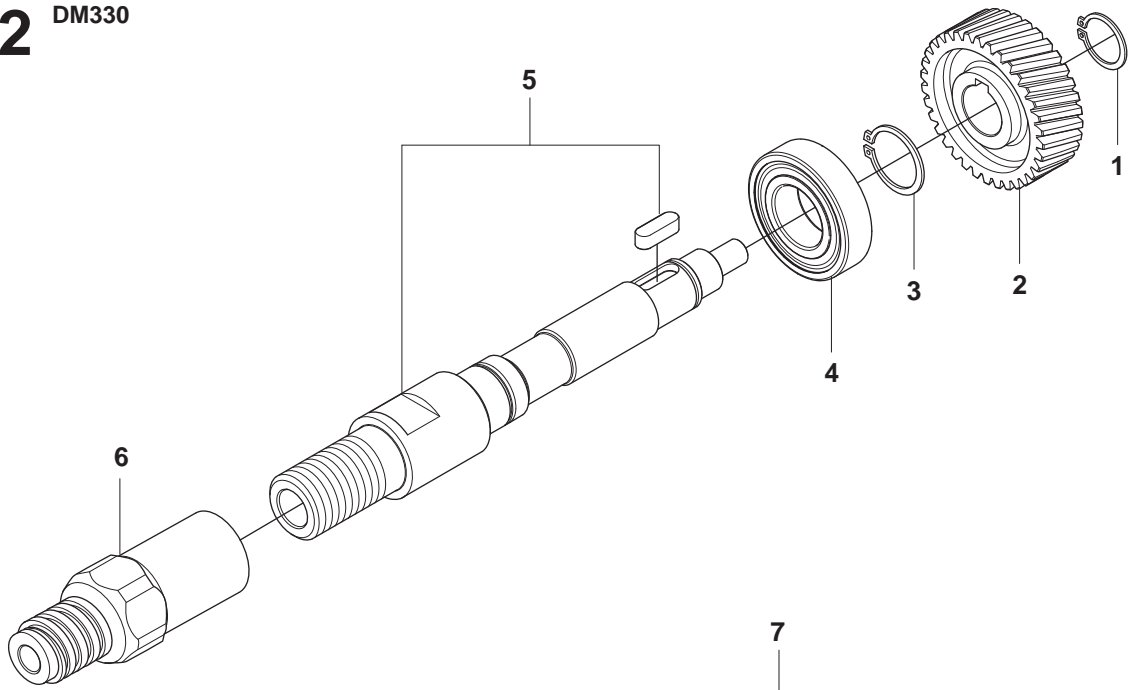

Page A2
DM330

Pos.	Part No.	Description	Quantity	Notes
1	735 31 25-00	CIRCLIP	1	
2	544 39 92-01	GEAR WHEEL	1	Low speed version
2	544 39 93-01	GEAR WHEEL	1	High speed version
3	735 31 30-00	CIRCLIP	1	
4	738 22 06-29	BALL BEARING	1	
5	525 82 62-01	SPINDLE SHAFT ASSY	1	
6	531 14 09-58	ADAPTER	1	SE, FI, NO, DK
7	544 44 45-01	SLIP CLUTCH ASSY	1	
8	738 22 01-19	BALL BEARING	2	
9	525 82 61-01	KIT WEAR PARTS	1	
10	525 82 60-01	OIL PIPE ASSY	1	
11A	525 82 59-01	GEAR WHEEL ASSY	1	Low speed version
11B	525 82 59-02	GEAR WHEEL ASSY	1	High speed version
12	544 39 77-01	GEAR WHEEL SHAFT	1	

B1 DM330

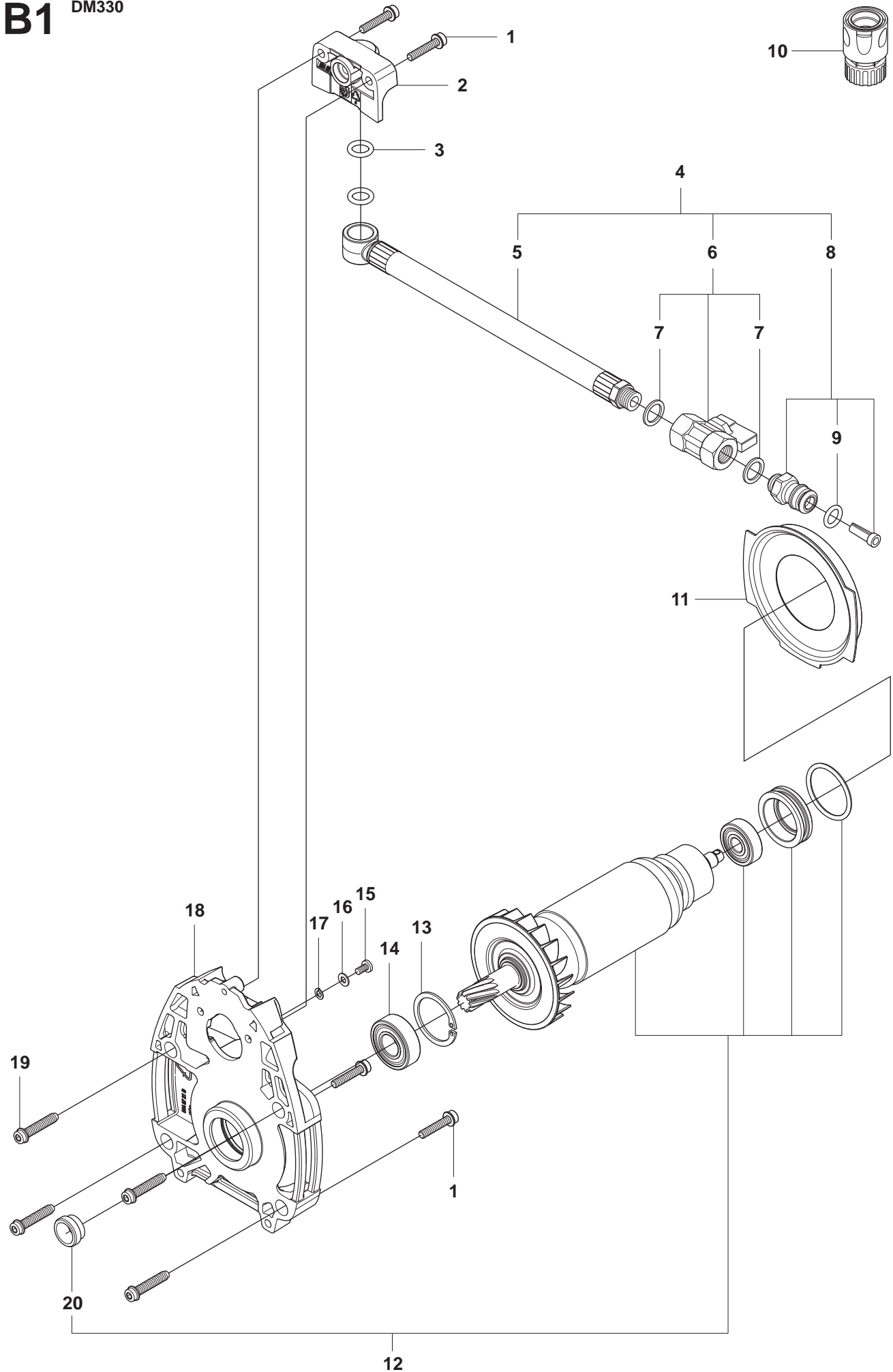

Page B1
DM330

Pos.	Part No.	Description	Quantity	Notes
1	503 20 07-25	SCREW	4	
2	544 88 27-01	BRACKET	1	
3	502 49 65-01	O-RING	2	
4	502 30 44-01	HOSE ASSY	1	incl 5,6,7,8,9
5	510 12 59-01	HOSE KIT	1	
6	510 19 59-01	VALVE KIT	1	incl 7
7	531 07 42-60	FIBRE WASHER	2	
8	510 11 20-01	NIPPLE KIT	1	incl 9
9	505 10 35-01	O-RING	1	
10	503 26 60-02	COUPLER	1	USA, CANADA
11	544 80 60-01	AIR CONDUCTOR	1	
12A	505 15 50-01	ROTOR	1	incl 20 110V
12B	505 15 51-01	ROTOR	1	incl 20 230V
13	735 31 33-10	CIRCLIP	1	
14	738 22 02-19	BALL BEARING	1	
15	724 12 87-59	SCREW	1	
16	734 11 36-01	WASHER	1	
17	735 21 36-01	LOCK WASHER	1	
18	544 40 25-01	COVER	1	
19	503 21 88-30	SCREW	4	
20	544 39 76-01	SLEEVE	1	

B2 DM330

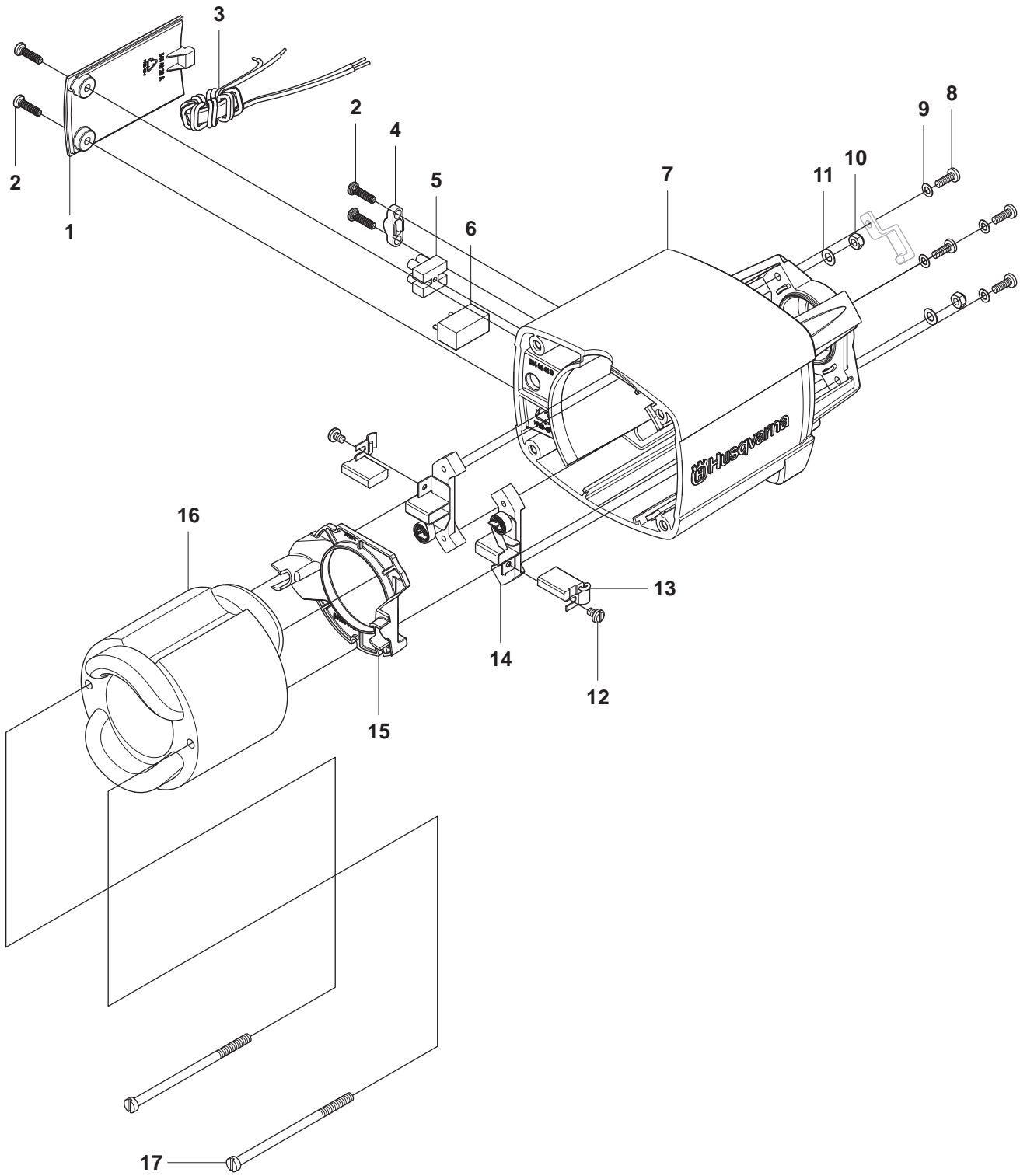

Page B2
DM330

Pos.	Part No.	Description	Quantity	Notes
1	544 40 28-01	COVER	1	
2	503 21 20-01	SCREW	4	
3	504 54 50-01	FILTER	1	230V Only
4	544 12 32-01	CABLE CLAMP	1	
5A	504 54 62-01	TERMINAL BLOCK	1	110V
5B	504 54 62-02	TERMINAL BLOCK	1	230V
6	504 54 63-01	CAPACITOR	1	
7	544 44 49-01	MOTOR HOUSING	1	
8	724 12 91-01	SCREW	4	
9	735 11 36-50	SPRING WASHER	4	
10	732 21 14-01	LOCK NUT	2	
11	735 11 46-50	SPRING WASHER	2	
12	723 22 85-81	SCREW	2	
13	506 22 58-02	CARBON BRUSH	2	
14	531 03 18-93	BRUSH HOLDER	2	
15	544 80 61-01	AIR CONDUCTOR	1	
16A	506 22 51-10	STATOR ASSY	1	110V
16B	506 22 51-20	STATOR ASSY	1	230V
17	506 22 53-01	SCREW	2	

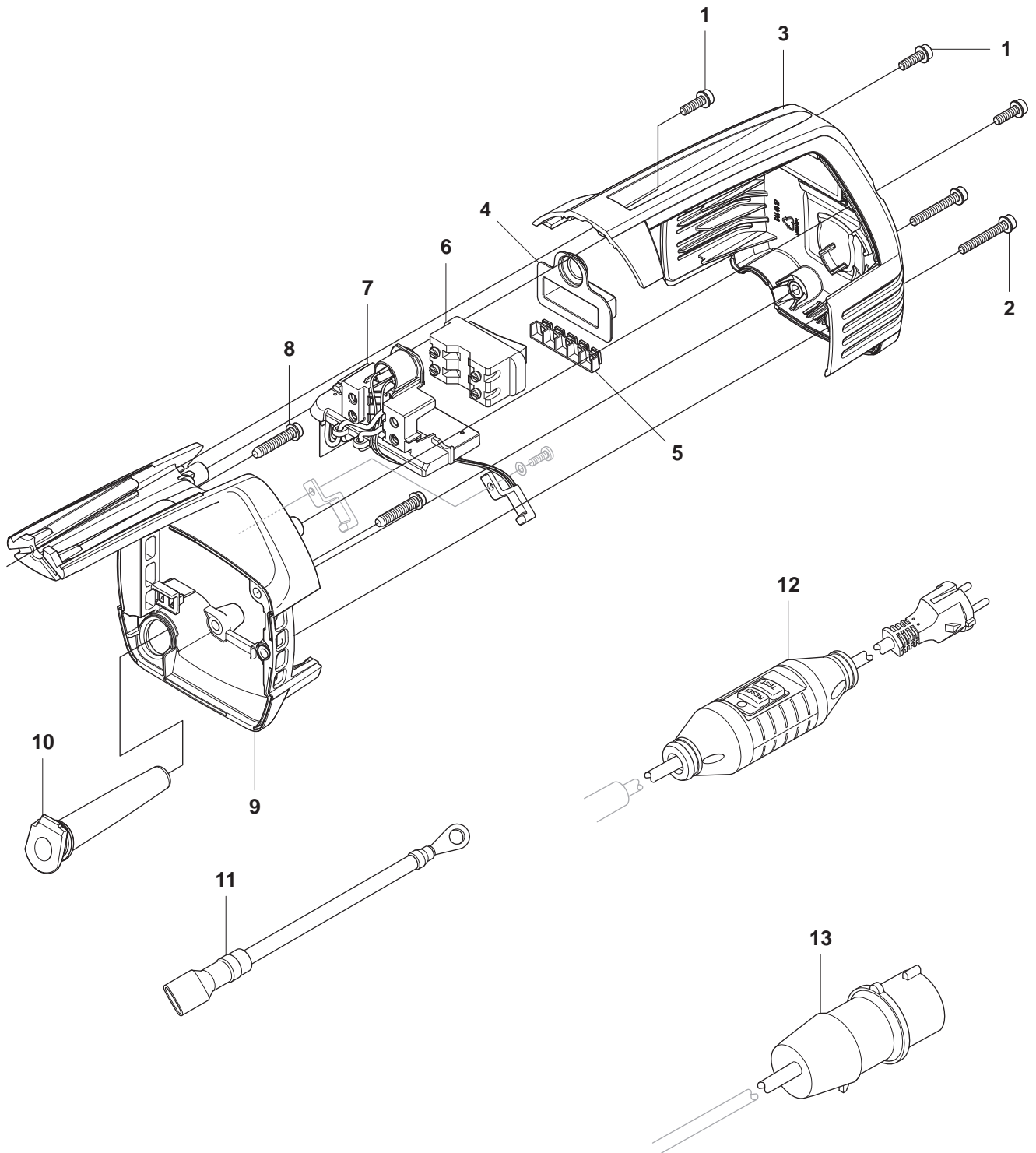

Page C
DM330

Pos.	Part No.	Description	Quantity	Notes
1	503 20 07-16	SCREW	3	
2	503 20 07-35	SCREW	2	
3	544 84 80-01	COVER	1	
4	544 80 62-01	PROTECTIVE CAP	1	
5	544 80 63-01	PROTECTIVE CAP	1	
6	531 07 38-91	SWITCH	1	
7	504 20 90-01	HOLDER ELECTRONICS	1	110V
7	504 20 90-02	HOLDER ELECTRONICS	1	230V
8	503 21 88-30	SCREW	2	
9	544 84 79-01	FRAME	1	
10	531 03 18-86	CABLE SLEEVE	1	
11	506 95 70-01	JOINTING CABLE	1	110V
12A	505 44 33-02	CABLE	1	230V incl PRCD 10mV, EU
12B	521 90 72-02	CABLE	1	230V incl PRCD 10mV, AU
13A	521 91 90-02	CABLE	1	110V UK
13B	510 18 13-03	CABLE	1	110V US

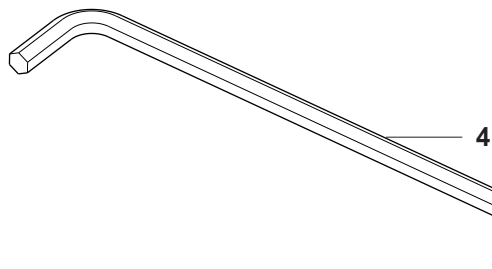
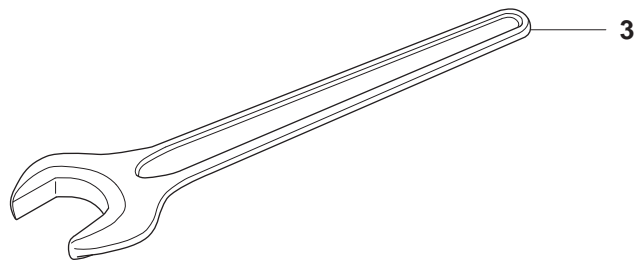
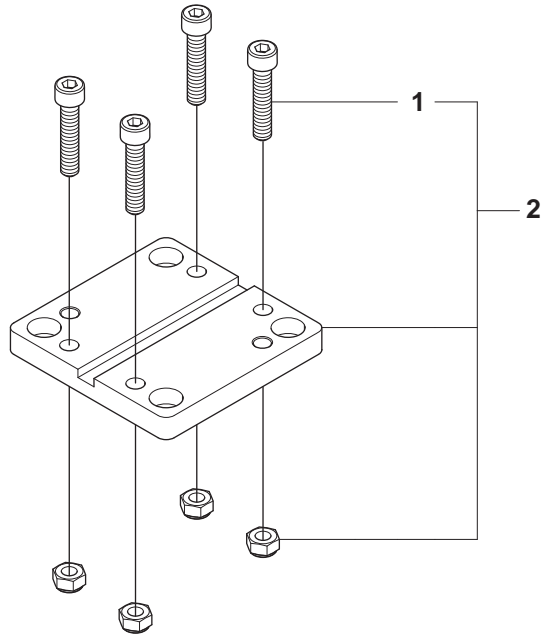

Page D
DM330

Pos.	Part No.	Description	Quantity	Notes
1	725 54 59-01	SCREW	4	
2	522 93 68-01	KIT, ADAPTER DS	1	
3	531 14 09-52	SPANNER 32	1	32mm
4	525 43 76-01	ALLEN KEY	1	