

## CONTENTS:

- 1) Fuel tank, Tubular grip
- 2) Hood, Air filter, Muffler
- 3) Cylinder, Crankcase
- 4) Ignition electronics, Starter
- 5) Oil pump, Clutch
- 6) Chain brake
- 7) Carburetor
- 8) Accessories

### 1) FUEL TANK, TUBULAR GRIP

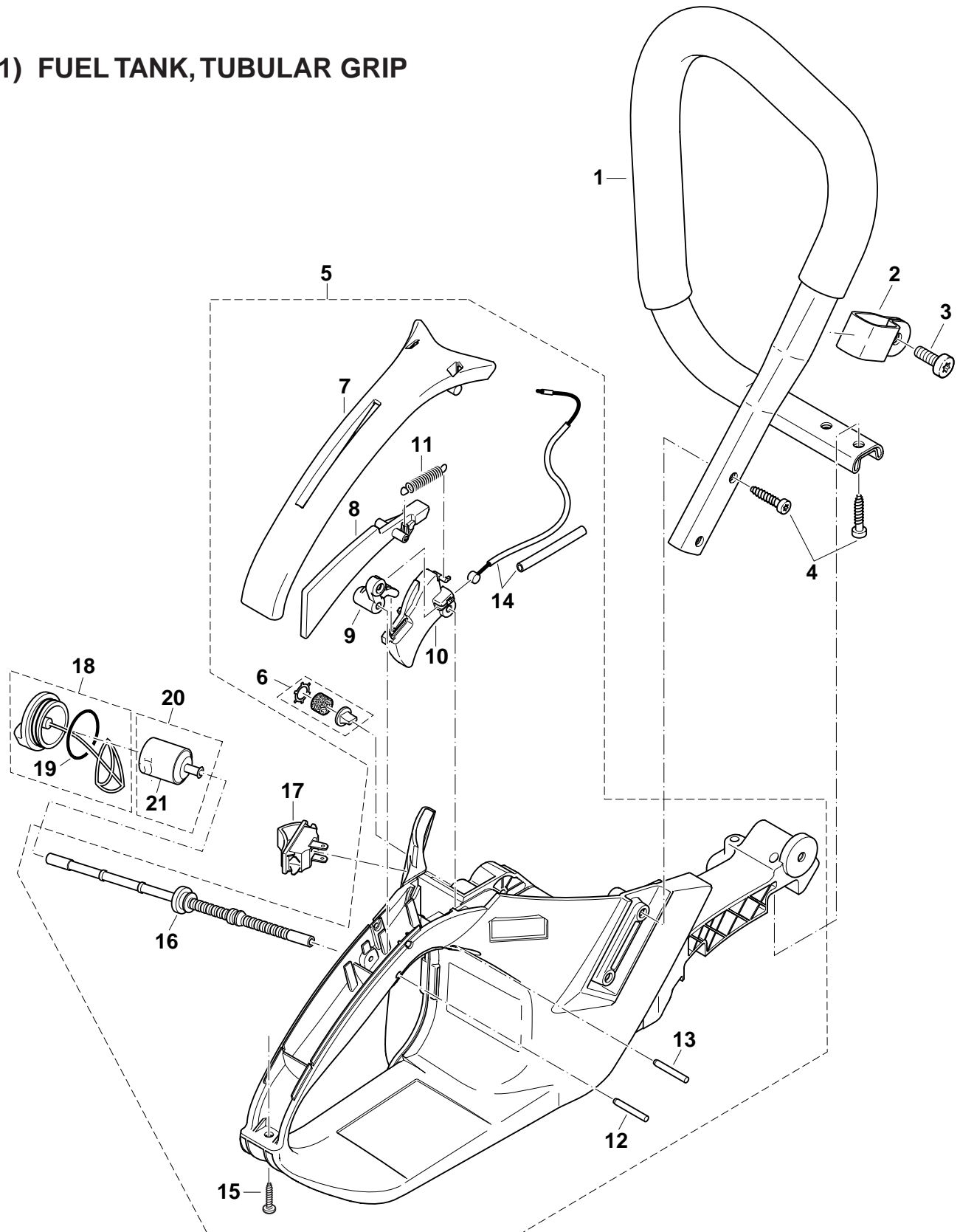

## 2) HOOD, AIR FILTER, MUFFLER

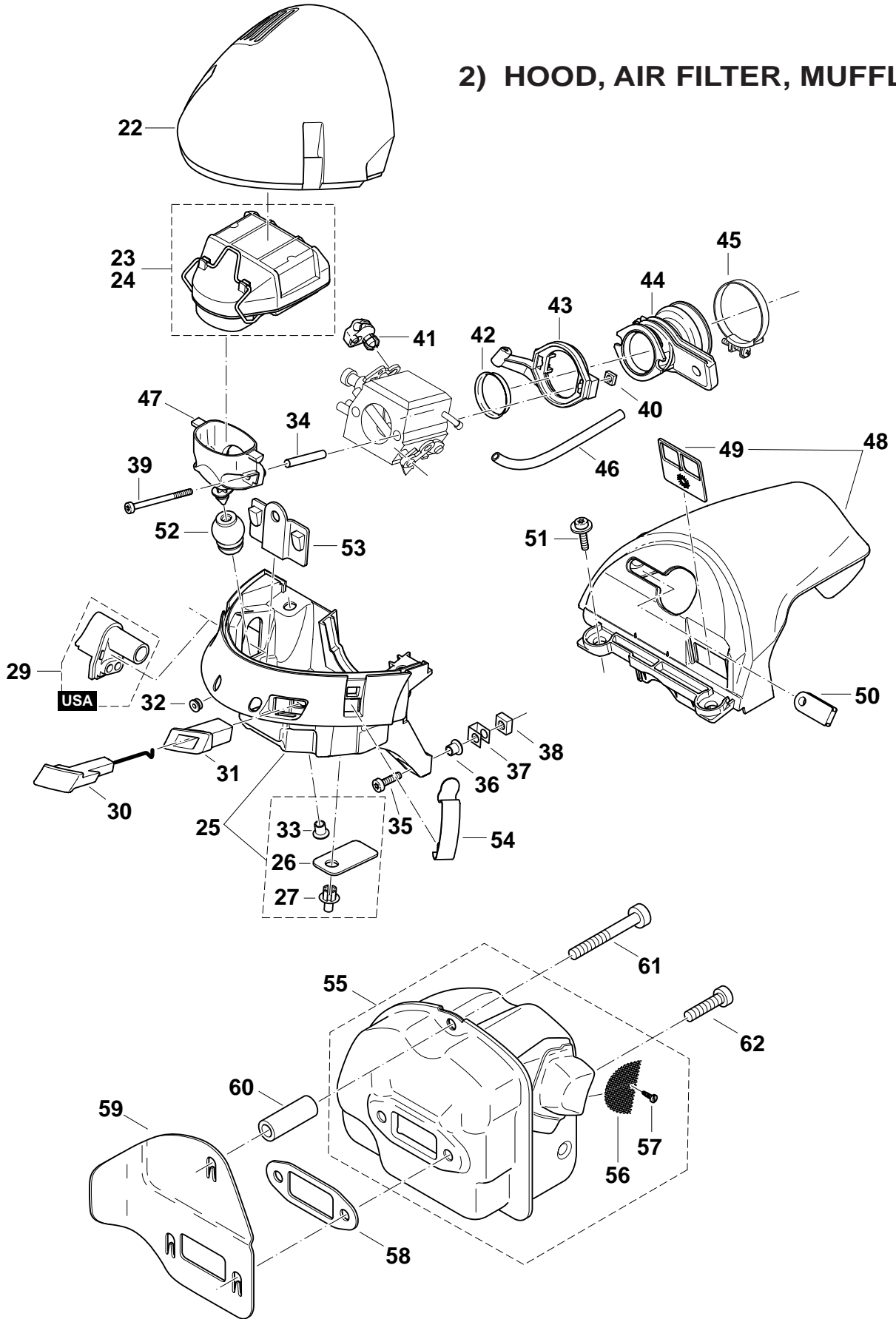

### 3) CYLINDER, CRANKCASE

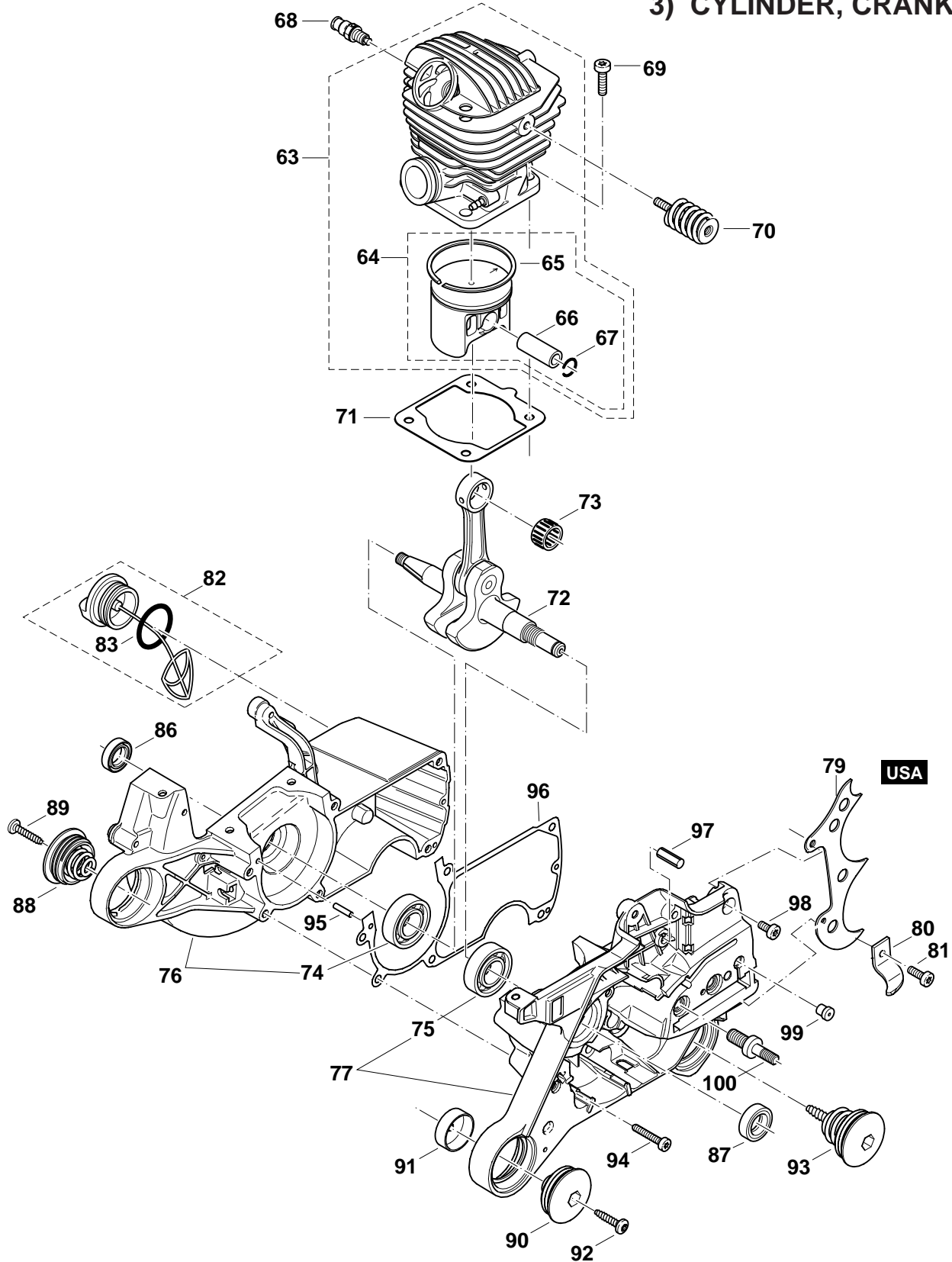

### 4) IGNITION ELECTRONICS, STARTER

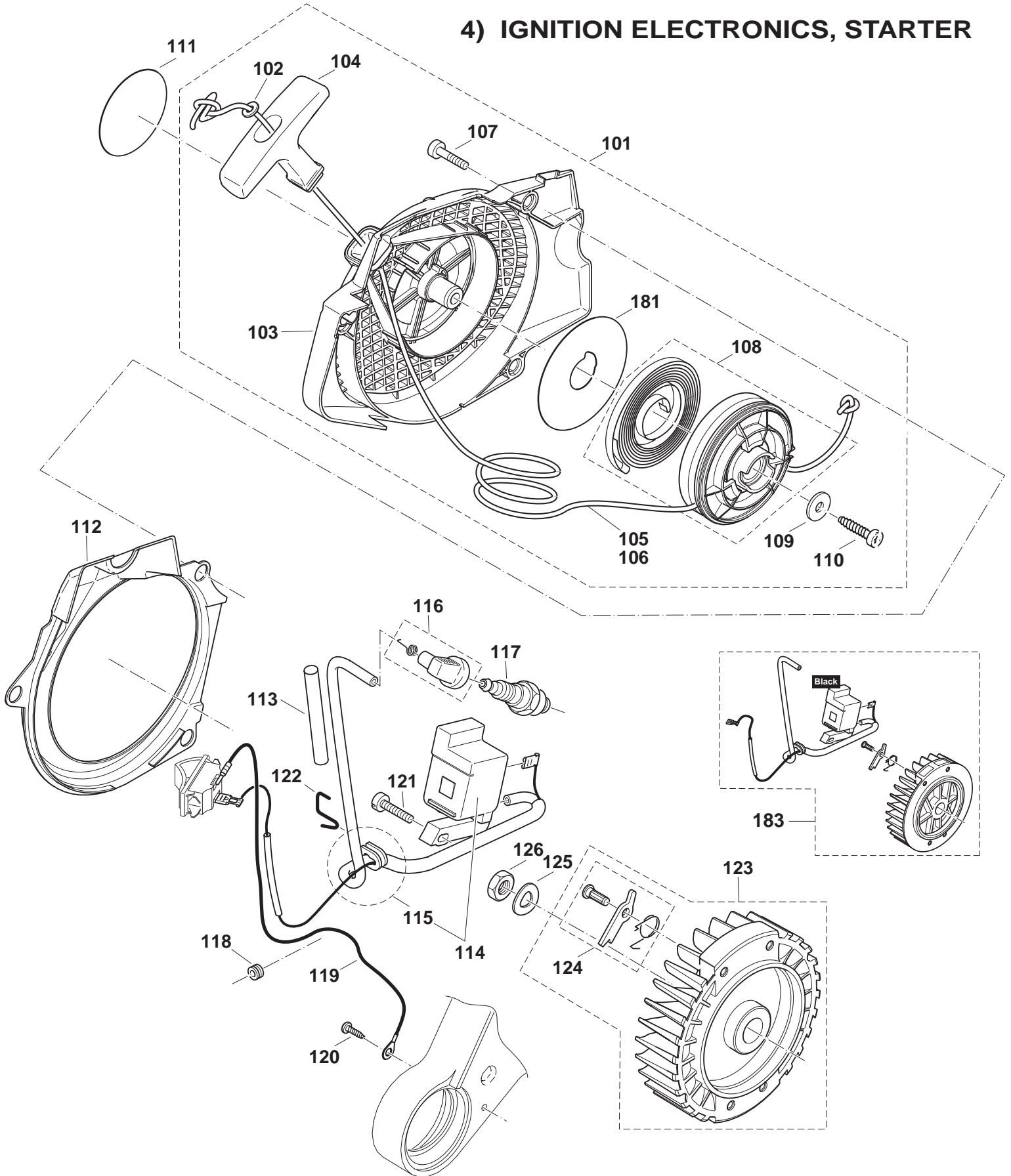

### 5) OIL PUMP, CLUTCH

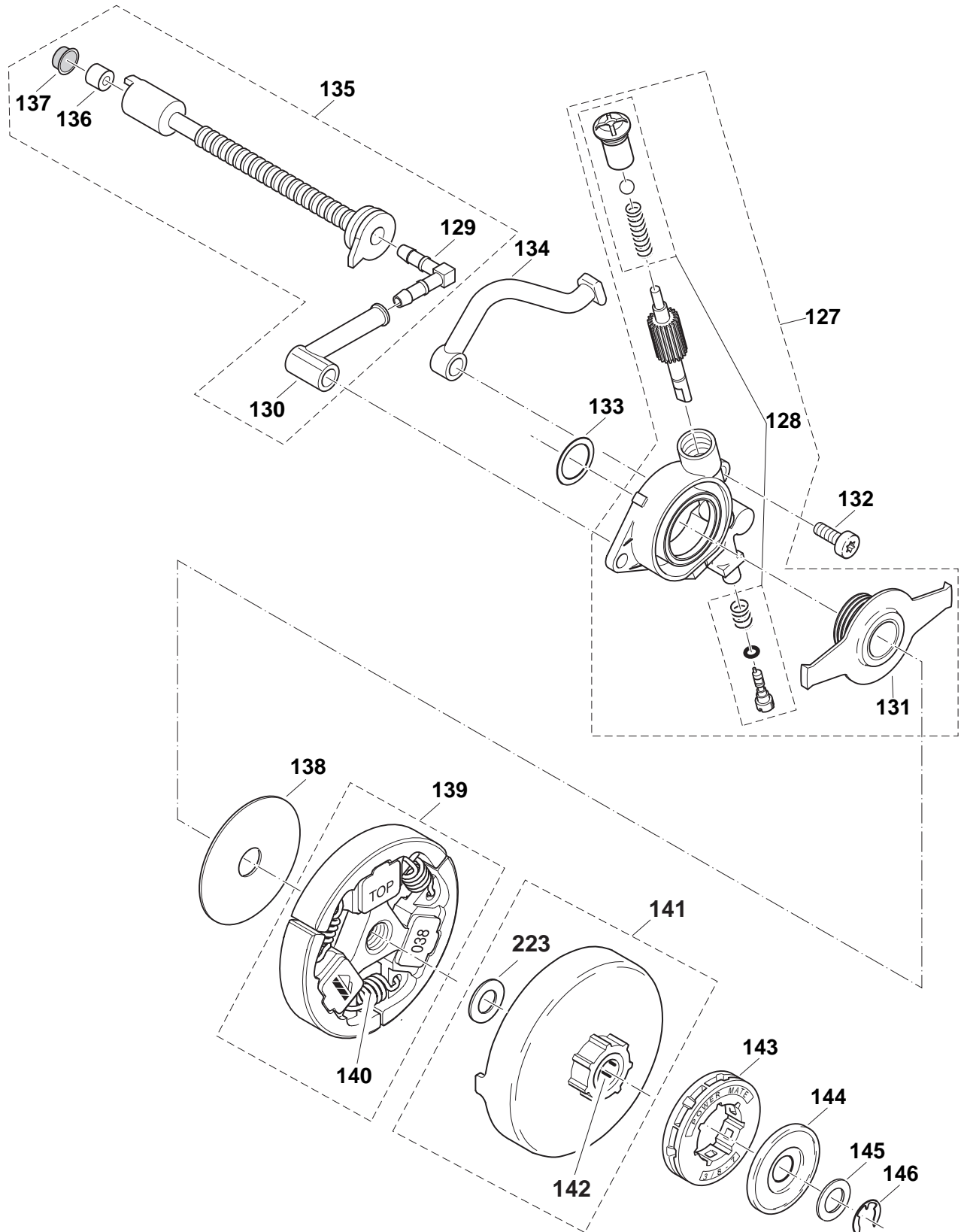

### 6) CHAIN BRAKE

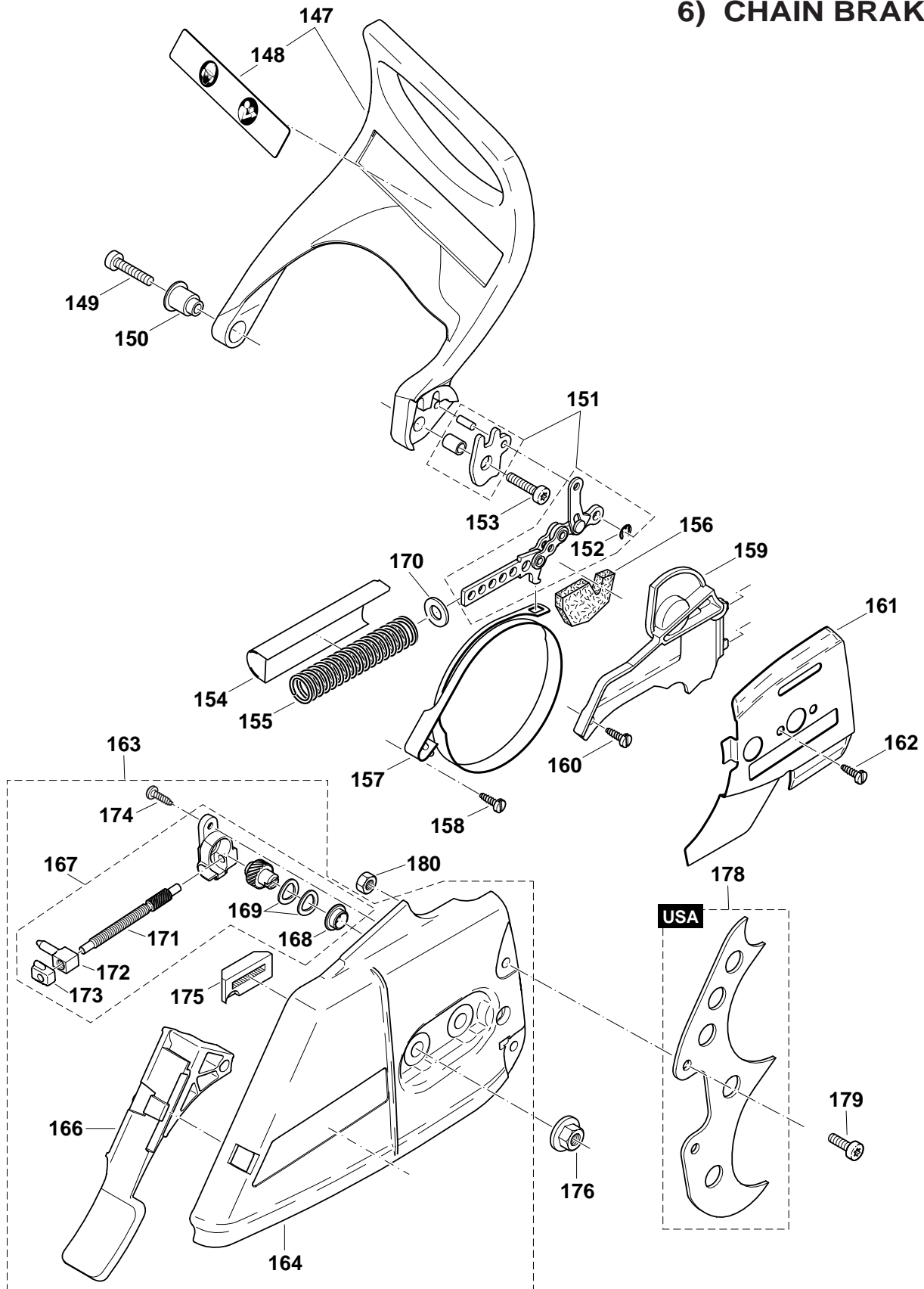

### 7) CARBURETOR

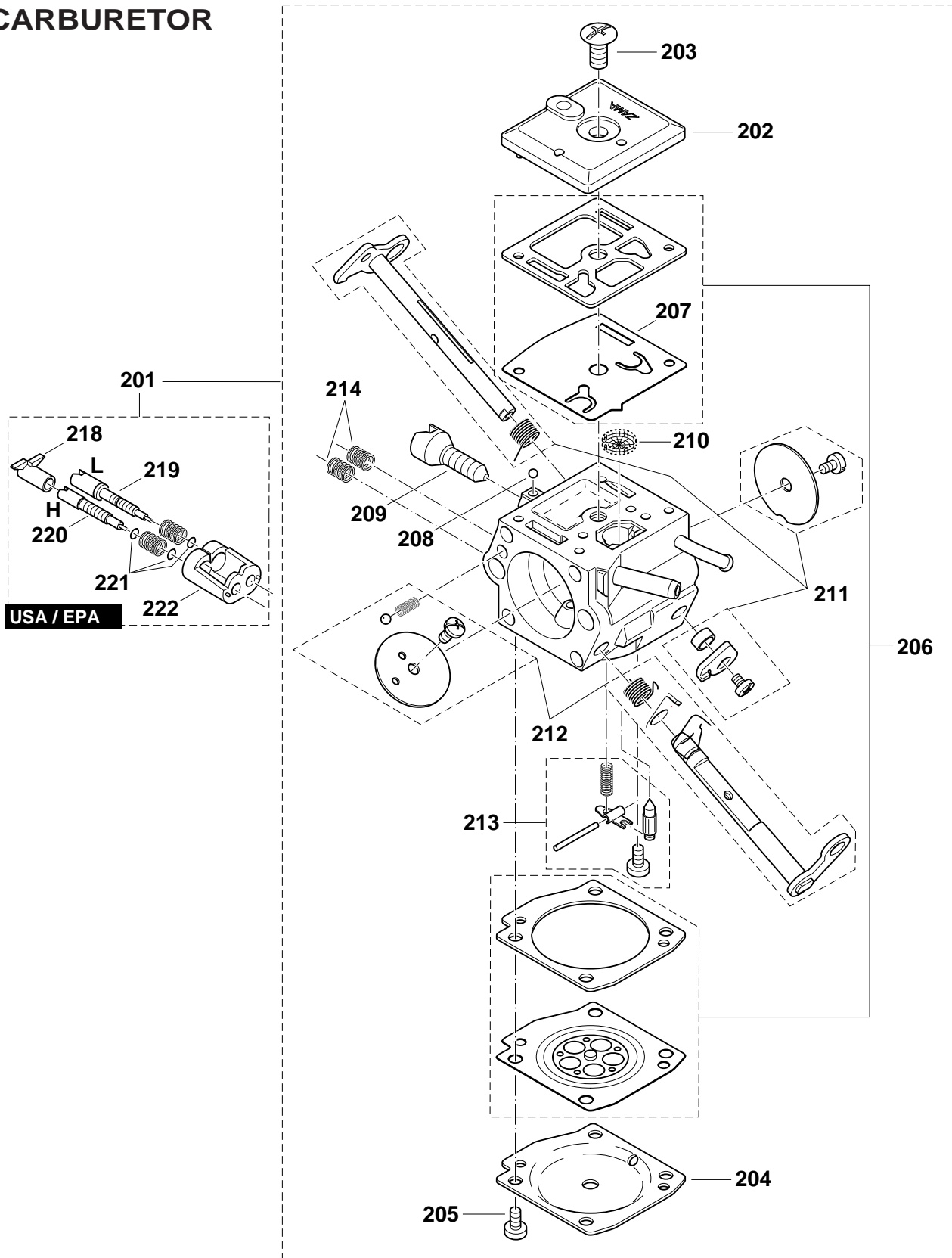



### 8) ACCESSORIES

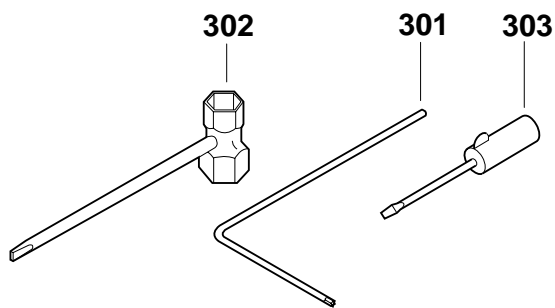
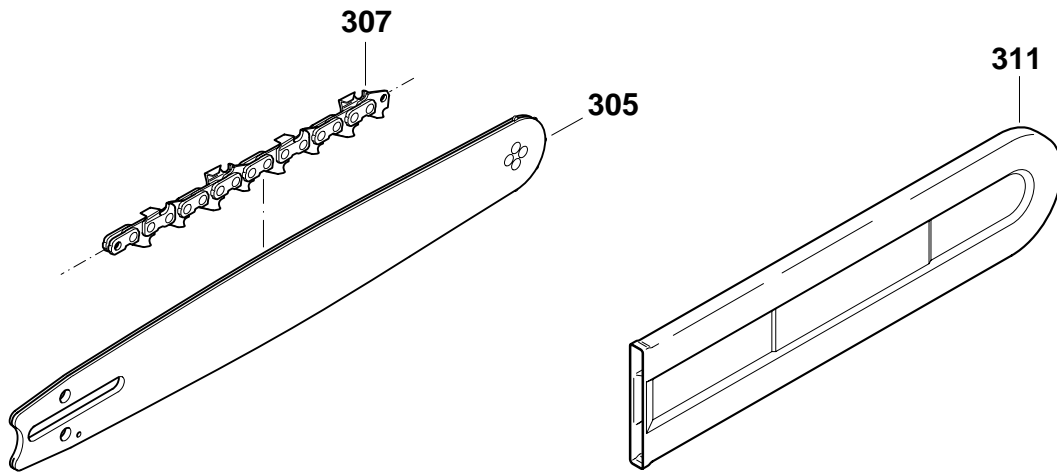



PARTS BREAKDOWN  
rev 4\_01/19/2012

DCS640120

Products with multiple versions are listed in subsiding order with the newest version on top not indented.

Corresponding bulletins are attached. Select bulletin name or attachment to view.

Tech Bulletin	Fig. No.	Part No.	Description	Q'ty	Unit	Notes
	1	038-310-020	TUBULAR HANDLE ASSY	1		
	2	038-310-061	CLAMP, DCS6401	1		
	3	908-006-145	SCREW 6x14	1		
	4	913-455-204	SCREW 5.5x20	4		
	5	038-114-608	TANK CPL., DCS6401	1		
	5	038-114-607	TANK CPL., DCS6401	1		
	5	038-114-606	TANK CPL.BLUE, DCS6401	1		
	5	038-114-604	TANK CPLT, DCS6401	1		
	5	038-114-601	TANK COMPLETE, BLUE, DCS6401	1		
	5	038-114-600	TANK CPL.,BLUE	1		
<u>2008-04</u>	6	957-114-061	AIR VALVE CPL, DCS6401	1		
	6	957-114-060	AIR VALVE CPL.(fuel)	1		
	7	038-114-631	GRIP PLATE BLUE,	1		
	7	038-114-630	GRIP PLATE, blue	1		
	8	038-117-020	CATCH LEVER	1		
	9	038-117-030	ROCKER	1		
	10	038-117-010	THROTTLE LEVER	1		
	11	038-117-050	SPRING	1		
	12	935-930-240	CYLINDRICAL PIN 3x24	1		
	13	935-930-280	CYLINDRICAL PIN 3x28	1		
	14	038-117-041	BOWDEN CABLE, DCS6421	1		
	14	010-117-040	BOWDEN CABLE	1		
	15	913-340-204	SCREW 4x20 S27	1		
	16	038-114-051	FUEL LINE, DCS6401	1		
	16	038-114-050	FUEL LINE	1		
<u>2009-15</u>	17	975-001-241	SHORT CIRCUIT SWITCH, DCS6401	1		
	17	975-001-240	SHORT CIRCUIT SWITCH, DSC6401,T1	1		
	17	975-001-210	SHORT-CIRCUIT SWITCH	1		
	18	010-114-050	TANK CAP cpl.	1		
	19	963-228-030	PACKING RING 28x3	1		
	20	963-601-122	SUCTION HEAD CPL., DPC7321	1		
	20	963-601-121	SUCTION HEAD, DPC7321	1		
	20	963-601-120	SUCTION HEAD FUEL, DCS6000I21	1		
	20	963-601-130	SUCTION HEAD	1		
	21	963-601-240	FELT for SUCTION HEAD	1		
	22	038-118-622	COVER GREY, DCS6401	1		
	22	038-118-621	COVER, GREY, DCS6401	1		
	22	038-118-620	COVER GREY	1		
	23	038-173-101	AIR FILTER CPL., DCS6401	1		
	23	038-173-100	AIR FILTER cpl.	1		
	24	038-173-011	AIR FILTER COMPLETE, NYLON, DCS6401	1		
	24	038-173-010	AIR FILTER cpl.nylon	1		
	25	038-118-670	BOTTOM BLUE, DCS6401	1		
	25	038-118-630	BOTTOM, blue	1		
	26	038-118-110	RUBBER FLAP	2		
	27	938-650-062	RIVET	2		
	29	038-118-081	ADJUSTING GUIDE, DCS6421	1		
	29	038-118-120	ADJUSTING GUIDE	1		
	30	038-155-052	CHOKE LINKAGE, DCS6401	1		



PARTS BREAKDOWN  
rev 4\_01/19/2012

DCS640120

Products with multiple versions are listed in subsiding order with the newest version on top not indented.

*Corresponding bulletins are attached. Select bulletin name or attachment to view.*

Tech Bulletin	Fig. No.	Part No.	Description	Q'ty Unit	Notes
	30	038-155-051	CHOKE SHAFT, DCS6401	1	
	30	038-155-050	CHOKE SHAFT	1	
	31	038-155-020	CHOKE GUIDE	1	
	32	965-401-020	RUBBER BUSH	1	
	33	001-118-100	BUSHING	2	
	34	038-155-060	SPACER L=30MM	2	
	35	908-005-205	SCREW 5x20	2	
	36	001-118-100	BUSHING	2	
	37	038-111-050	CLIP	2	
	38	038-111-060	SQUARE NUT M5	2	
	39	908-204-555	SCREW 4x55	2	
	40	921-804-004	SQUARE NUT M4	2	
	41	038-155-012	RETAINING CLIP, DCS6401	1	
	41	038-155-011	RETAINING CLIP, DCS6401	1	
	41	038-155-010	RETAINING CLIP	1	
	42	038-131-031	INSERT FOR SUCTION HOSE, DCS6401	1	
	42	038-131-030	INSERT for SUCTION HOSE	1	
	43	038-171-041	FLANGE	1	
	44	038-131-011	SUCTION HOSE, DCS6401	1	
	45	965-603-050	HOSE CLAMP	1	
	46	965-452-382	TUBE	1	
	46	965-452-380	TUBE,L=65	1	
	47	038-171-011	CONNECTING MUFF, DCS7901	1	
	48	038-118-690	HOOD cpl., grey	1	
	49	038-118-140	INSERT	1	
	50	038-118-130	CABLE GUIDE	1	
	51	917-105-205	SCREW M5x20	2	
	52	038-171-030	HOLDER	1	
	53	038-118-100	PLUG	1	
	54	038-118-071	STEEL CLIP	2	
	55	038-174-200	MUFFLER	1	
	56	038-174-040	SPARK ARRESTOR SCREEN	1	
	57	915-035-140	SCREW, DPC6410	1	
	57	915-035-100	SCREW 3.5x10	1	
	58	965-531-131	GASKET, DPC8112	1	
	58	965-531-130	GASKET	1	
	59	038-174-021	COVER PLATE, DCS6401	1	
	59	038-174-020	COVER PLATE	1	
	60	038-174-030	CONNECTING LINK	1	
	61	908-305-405	SCREW M5x40	1	
	62	908-405-205	SCREW M5x20	2	
	63	040-130-033	CYLINDER/PISTON CPL., DCS6401	1	
	63	040-130-032	CYLINDER/PISTON CPL., DCS6401	1	
	63	040-130-030	CYLINDER/PISTON cpl.	1	
	64	325-132-033	PISTON CPL. (47), DPC6410	1	
	64	325-132-032	PISTON CPL.(47), DPC6410	1	
	64	325-132-031	PISTON cpl.	1	
	65	325-132-050	PISTON RING (D=47)	1	
	66	119-132-030	PISTON PIN	1	



PARTS BREAKDOWN  
rev 4\_01/19/2012

DCS640120

Products with multiple versions are listed in subsiding order with the newest version on top not indented.

Corresponding bulletins are attached. Select bulletin name or attachment to view.

Tech Bulletin	Fig. No.	Part No.	Description	Q'ty Unit	Notes
	67	119-132-060	SPRING RING C12x1	2	
	68	001-131-150	DECOMPRESSION VALVE	1	
<u>2007-13</u>	69	908-805-235	SCREW W/SPRING WASHER, DPC7331	4	
	69	908-005-205	SCREW 5x20	4	
	70	038-114-152	SPRING W/THREADED INSERT, DCS6401	1	
	70	038-114-151	SPRING W/THREADED INSERT, DCS6401	1	
	70	038-114-150	SPRING W/THREADED INSERT	1	
<u>2008-03</u>	71	965-531-160	GASKET, DPC6410	1	
	71	965-531-121	GASKET	1	
<u>2006-13</u>	72	038-120-021	CRANKSHAFT, DCS6401	1	
	72	038-120-020	CRANKSHAFT cpl.	1	
	73	962-210-019	NEEDLE CAGE	1	
	74	960-102-159	BALL BEARING 6202	1	
	75	960-102-179	BALL BEARING 6203 C4	1	
	76	038-111-660	CRANKCASE MAG.SIDE-BLUE, DCS6401	1	
	76	038-111-630	CRANKCASE MAG.SIDE,blue	1	
	77	038-111-641	CRANKCASE CLUTCH SIDE,BLUE, DCS6401	1	
	77	038-111-640	CRANKCASE CLUTCH SIDE, blue	1	
	79	038-250-201	SPIKE BAR (CRANKCASE), DCS6401	1	
	79	038-250-200	SPIKE BAR	1	
	80	038-111-171	CHAIN CATCH, DCS6401	1	
	80	038-111-080	CHAIN CATCH	1	
	81	908-005-165	SCREW 5x16	1	
	82	010-114-050	TANK CAP cpl.	1	
	83	963-228-030	PACKING RING 28x3	1	
	86	962-900-052	RADIAL RING	1	
	87	962-900-061	RADIAL RING 17x28x5/4	1	
	88	038-114-130	SPRING cpl.,w/cap	1	
	89	913-455-204	SCREW 5.5x20	1	
	90	038-114-130	SPRING cpl.,w/cap	1	
	91	038-114-191	POT, DCS6401	1	
	91	038-114-190	POT	1	
	92	913-455-204	SCREW	1	
	93	038-114-141	SPRING, DCS6401	1	
	93	038-114-140	SPRING cpl., w/cap	1	
	94	908-005-305	SCREW 5x30	6	
	95	936-430-160	SPIRAL CLAMPING PIN 3x16	2	
	96	038-111-042	GASKET	1	
	97	934-660-250	SLOTTED PIN 6x24	1	
	98	908-005-125	SCREW 5X12	1	
	99	010-245-030	VENT VALVE	1	
	100	038-232-010	BOLT	2	
	101	038-160-610	STARTER ASS'Y. BLUE, DCS6421	1	
<u>2009-13</u>	101	038-160-604	STARTER ASS'Y., DCS6401	1	
	101	038-160-603	STARTER ASS'Y, DCS6401	1	
	101	038-160-600	STARTER ASSY.,blue	1	
	102	928-405-000	SPRING WASHER	1	
	103	038-112-630	FAN HOUSING, blue	1	
	104	001-161-020	STARTER GRIP, DPC6410	1	



# PARTS BREAKDOWN

rev 4\_01/19/2012

DCS640120

Products with multiple versions are listed in subsiding order with the newest version on top not indented.

*Corresponding bulletins are attached. Select bulletin name or attachment to view.*

Tech Bulletin	Fig. No.	Part No.	Description	Q'ty Unit	Notes
	104	001-161-010	STARTER GRIP	1	
	105	108-164-020	STARTER ROPE,(L=980MM)	1	
	106	985-000-155	STARTER ROPE, (L=100M)	1	
	107	908-605-205	SCREW M5x20	3	
	108	038-162-024	CABLE DRUM, DCS6401	1	
	108	038-162-022	CABLE DRUM CPL., DCS6401	1	
	108	038-162-021	CABLE DRUM cpl.	1	
	109	924-605-510	WASHER 5.5x18x1.6	1	
	110	913-455-204	SCREW 5.5x20	1	
	111	980-115-329	LABEL, DCS6401	1	
	111	980-114-835	LABEL	1	
	112	038-112-020	AIR DUCT	1	
	113	970-502-110	INSULATING HOSE,L=140	1	
	114	038-143-041	IGNITION COIL RED, DCS6401H	1	
	114	038-143-040	IGNITION COIL-RED, DCS6401H	1	
	114	038-143-020	IGNITION COIL	1	
	115	038-143-030	CABLE HARNESS	1	
	116	957-604-240	PLUG CAP	1	
	117	965-603-021	SPARK PLUG	1	
	118	965-401-011	RUBBER BUSH	1	
	119	970-311-540	EARTH CABLE	1	
	120	915-135-100	SCREW BZ3.5x9.5	1	
	121	908-304-205	SCREW 4x10x20 S27	2	
	122	038-111-110	CLIP	2	
	123	957-141-000	FLYWHEEL, DCS6401	1	
	123	038-141-000	FLYWHEEL ASSY.	1	
	124	108-166-051	STARTER RATCHET cpl.	2	
	125	926-208-001	SPRING WASHER	1	
	126	920-208-024	HEXAGONAL NUT M8x1	1	
	127	038-245-011	OIL PUMP CPL., DCS6401	1	
	127	038-245-010	OIL PUMP cpl.	1	
	128	030-245-070	REPAIR KIT	1	
	129	001-245-140	ANGULAR NIPPLE	1	
	130	038-245-110	OIL LINE	1	
	131	038-245-031	PUMP DRIVE, DCS6401	1	
	132	908-005-125	SCREW 5x12	2	
	133	038-224-021	DISC, DCS6401	1	
	133	038-224-020	DISC	1	
<b><u>2006-17</u></b>	134	038-245-061	OIL LINE, DCS6401	1	
	134	038-245-060	OIL LINE	1	
	135	038-245-020	SUCTION LINE OIL cpl.	1	
	136	900-005-066	DISTANCE RING	1	
	137	963-601-100	STRAINER SCREEN	1	
	138	001-182-042	GUIDE DISC, DCS6401	1	
	138	001-182-041	GUIDE DISC	1	
	139	038-180-011	CLUTCH ASS'Y, DCS6401	1	
	139	038-180-010	CLUTCH ASSY.	1	
	140	024-184-021	SPRING	3	
	141	957-223-092	CLUTCH DRUM CPL., DCS6401	1	



PARTS BREAKDOWN  
rev 4\_01/19/2012

DCS640120

Products with multiple versions are listed in subsiding order with the newest version on top not indented.

Corresponding bulletins are attached. Select bulletin name or attachment to view.

Tech Bulletin	Fig. No.	Part No.	Description	Q'ty Unit	Notes
	141	957-223-091	CLUTCH DRUM, DCS6401	1	
	141	957-223-090	CLUTCH DRUM CPL., DCS6401	1	
	142	962-300-009	NEEDLE SLEEVE, DCS510	1	
	143	119-224-070	RIM SPROCKET, T=3/8"	1	
	144	181-224-081	DISC, DCS510	1	
	144	181-224-080	DISC, DCS510	1	
	144	001-224-011	DISC	1	
	145	021-224-011	DISC, DCS340	1	
	145	021-224-010	DISC	1	
	146	927-408-000	WASHER, D=8x1.3	1	
	147	038-213-221	HAND GUARD CPL., DCS6401	1	
	147	038-213-220	HAND GUARD cpl.	1	
	148	980-114-237	LABEL	1	
	149	908-405-205	SCREW 5x20	1	
	150	038-213-160	BUSHING	1	
	151	957-213-030	BRAKING MECHANISM	1	
	152	927-304-000	WASHER 4	1	
	153	908-005-206	SCREW 5x20	1	
	154	038-213-150	POT	1	
	155	038-213-130	SPRING	1	
	156	038-213-200	FOAM SPONGE	1	
	157	038-213-010	BRAKE SPRING	1	
	158	915-135-100	SCREW BZ3.5x9.5	1	
	159	038-213-040	PLATE	1	
	160	915-135-100	SCREW BZ3.5x9.5	1	
	161	038-111-030	GUIDE PLATE	1	
	162	915-135-100	SCREW BZ3.5x9.5	1	
	163	038-213-641	SPROCKET GUARD CPL., DCS6401	1	
	163	038-213-640	SPROCKET GUARD CPL., DCS6401	1	
	163	038-213-602	SPROCKET GUARD CPL. BLUE, DCS6401	1	
	163	038-213-600	SPROCKET GUARD cpl.,blue	1	
	164	038-213-635	SPROCKET GUARD, blue	1	
	166	038-213-190	CHIP GUIDE	1	
	167	957-213-023	CHAIN TENSIONER, DCS6401	1	
	167	957-213-022	CHAIN TENSIONER, DCS6401	1	
	167	957-213-020	CHAIN TENSIONER cpl.	1	
	168	038-213-080	BUSHING	1	
	169	038-213-210	SPRING WASHER	2	
	170	028-213-010	WASHER 12x9	1	
	171	957-213-040	TENSIONING SCREW, DCS6401	1	
	172	038-213-091	SQUARE NUT, DCS6401	1	
	172	038-213-090	TENSIONING NUT	1	
	173	038-213-070	TENSIONING SCREW BEARING	1	
	174	915-135-100	SCREW BZ3.5x9.5	1	
	175	024-213-240	CHAIN GUIDE	1	
	176	923-208-004	HEX. NUT M8	2	
	178	038-250-211	SPIKE BAR, DCS6401	1	
	178	038-250-210	SPIKE BAR	1	
	179	908-005-125	SCREW M5x12	2	



PARTS BREAKDOWN  
rev 4\_01/19/2012

DCS640120

Products with multiple versions are listed in subsiding order with the newest version on top not indented.

Corresponding bulletins are attached. Select bulletin name or attachment to view.

Tech Bulletin	Fig. No.	Part No.	Description	Q'ty	Unit	Notes
	180	920-405-000	HEX. NUT M5	2		
	181	038-162-050	SPACER	1		
	183	010-038-141	FLYWHEEL/IGNITION COIL KIT, DCS6401	1		
	201	038-153-500	CARBURETOR CPL., , DCS6421	1		
<u>2009-13</u>	201	038-153-023	CARBURETOR, DCS6401	1		
	201	038-153-022	CARBURETOR, DCS6401	1		
	201	038-153-021	CARBURETOR, DCS6401	1		
	201	038-153-020	CARBURETOR (CM3)	1		
	202	038-153-030	PUMP COVER	1		
	203	038-153-360	SCREW	1		
	204	038-153-040	DIAPHRAGM COVER	1		
	205	001-153-020	SCREW	4		
	206	038-153-410	DIAPHRAGM/GASKETS SET, DCS6401	1		
	206	038-153-050	DIAPHRAGM/GASKETS SET, DCS6401	1		
	206	038-153-060	SET DIAPHRAGM/GASKETS	1		
	207	038-153-070	PUMP DIAPHRAGM	1		
	208	038-153-210	LOCKING BALL	1		
	209	038-153-220	IDLE STOP SCREW (S)	1		
	210	036-153-040	SCREEN, DCS34	1		
	210	028-153-180	SCREEN	1		
	211	957-153-061	THROTTLE SHAFT KIT, DCS6401	1		
	211	957-153-060	KIT THROTTLE SHAFT	1		
	212	957-153-050	KIT CHOKE SHAFT	1		
	213	957-153-051	CHOKE SHAFT KIT, DCS6401	1		
	213	957-153-070	CONTROL PARTS	1		
	214	038-153-260	SPRING	2		
	218	038-153-310	LIMITER CAP	1		
	219	038-153-290	IDLE ADJUSTM. SCREW-L	1		
	220	038-153-300	MAIN ADJUSTM. SCREW-H	1		
	221	038-153-250	WASHER	3		
	222	038-153-320	ADJUSTING GUIDE	1		
	223	900-007-010	WASHER, DCS6401	1		
	301	940-827-000	ANGLED SCREW DRIVER	1		
	302	941-719-131	UNIVERSAL WRENCH	1		
	303	944-340-001	SCREW DRIVER	1		
	305	445-050-665	20" GUIDE BAR .050, 3/8"	1		
	307	523-102-072A	20" CHAIN , .050-3/8,DCS6401-20	1		
	307	513-496-672	20" LOOP CHAIN .050, 3/8"	1		
	311	952-100-653	CHAIN PROTECTION,20-24"	1		