

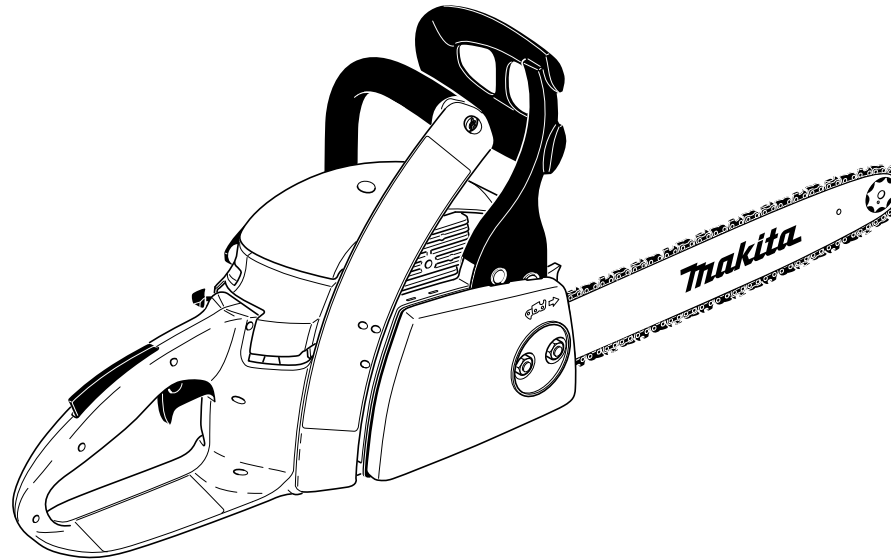

Spare Parts List
Ersatzteilliste
Liste de pièces détachées
Lista de piezas de repuesto

2011-06



- DCS34
- DCS34 (AUS,NZ)
- DCS34 (USA,CDN)
- DCS4610
- DCS4610 (AUS,NZ)
- DCS4610 (USA)

995700534 (D, GB, F, E)

DCS34, DCS34 , DCS34 ,
DCS4610, DCS4610 ,
DCS4610

1

Starter, Zündelektronik, Tank
Starter, ignition electronics, tank
Dispositif de démarrage, allumage électronique, réservoir
Bobina encendido, dispositivo de arranque, depósito

Makita[®]

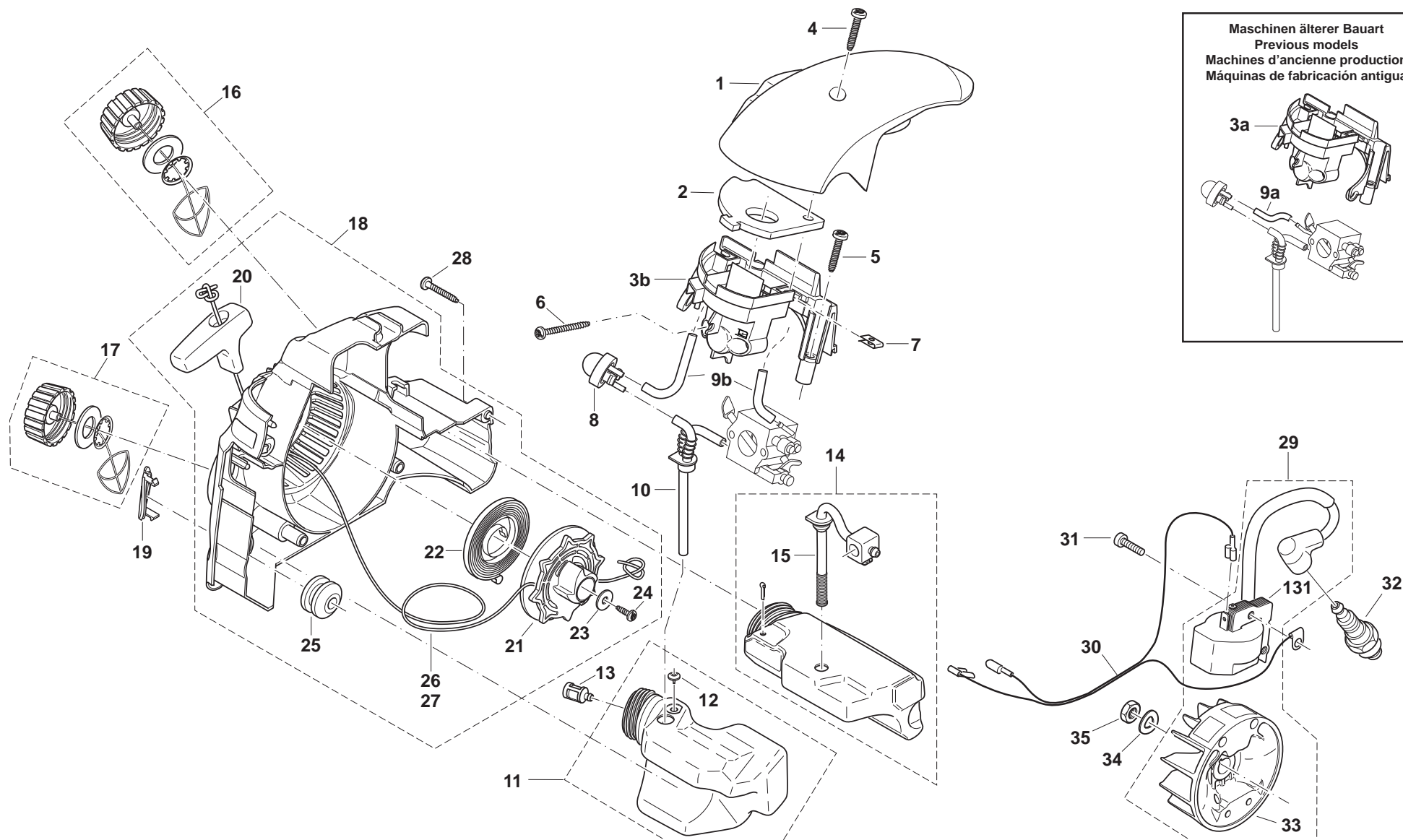

DCS34, DCS34 , DCS34 ,
DCS4610, DCS4610 ,
DCS4610

1

Starter, Zündelektronik, Tank
Starter, ignition electronics, tank
Dispositif de démarrage, allumage électronique, réservoir
Bobina encendido, dispositivo de arranque, depósito



Seite / Page	Pos.	DCS34	DCS34 (AUS,NZ)	DCS34 (USA,CAN)	DCS4610	DCS4610 (AUS,NZ)	DCS4610 (USA)	Teil-Nr. Part No. No. de pièce No. de pieza	Hinweise Notes Renseign. Nota	Bezeichnung	Spezifikation Specification	Description	Désignation	Denominación
1	1	1			1			036 118 012		ABDECKHAUBE ROT		HOOD RED	CAPOT PROTECTEUR ROUGE	CUBIERTA PROTECTORA ROJO
1	1				1			036 118 030	PL	ABDECKHAUBE SCHWARZ		HOOD BLACK	CAPOT PROTECTEUR NOIR	CUBIERTA PROTECTORA NEGRO
1	1	1	1	1	1	1	1	036 118 021		ABDECKHAUBE GRAU		HOOD GREY	CAPOT PROTECTEUR GRIS	CUBIERTA PROTECTORA GRIS
1	2	1	1	1	1	1	1	036 173 011		LUFTFILTER		AIR FILTER	FILTRE À AIR	FILTRO DE AIRE
1	3a	1	1	1	1	1	1	036 171 032	=> 2009	ANSAUGKRÜMMER		CONNECTING MUFF	MANCHON DE JONCTION	MANGUITO DE CONEXIÓN
1	3b	1	1	1	1	1	1	036 171 032	2010 =>	ANSAUGKRÜMMER		CONNECTING MUFF	MANCHON DE JONCTION	MANGUITO DE CONEXIÓN
1	4	3	3	3	3	3	3	913 650 304		INNENSTERN-SCHLITZ SCHRAUBE	5x30	SCREW	VIS	TORNILLO
1	5	2	2	2	2	2	2	913 650 304		INNENSTERN-SCHLITZ SCHRAUBE	5x30	SCREW	VIS	TORNILLO
1	6	2	2	2	2	2	2	913 650 504		INNENSTERN-SCHLITZ-SCHRAU BE	5x50	SCREW	VIS	TORNILLO
1	7	3	3	3	3	3	3	923 750 340		SCHNAPPMUTTER		NUT	ECROU	TUERCA
1	8	1	1	1	1	1	1	369 155 010		KRAFTSTOFFPUMPE "PRIMER"		PRIMER	POMPE À CARBURANT	BOMBA DE COMBUSTIBLE
1	9a	m	m	m	m	m	m	965 452 090	=> 2009	KRAFTSTOFFLEITUNG	L=32mm	FUEL LINE	CONDUITE CARBURANT	CONDUCTO COMBUSTIBLE
1	9b	m	m	m	m	m	m	965 452 090	2010 =>	KRAFTSTOFFLEITUNG	L=110mm	FUEL LINE	CONDUITE CARBURANT	CONDUCTO COMBUSTIBLE
1	10	1	1	1	1	1	1	965 404 980		KRAFTSTOFFLEITUNG		FUEL LINE	CONDUITE CARBURANT	CONDUCTO COMBUSTIBLE
1	11	1	1	1	1	1	1	036 114 151		KRAFTSTOFFTANK KPL.		FUEL TANK CPL.	RÉSERVOIR CARBURANT CPL.	DÉPÔSITO COMBUSTIBLE CPL.
1	12	1	1	1	1	1	1	965 404 220		GUMMIVENTIL		VALVE	SOUPAPE	VÁLVULA
1	13	1	1	1	1	1	1	963 601 380		KRAFTSTOFFFILTER		SUCTION HEAD	TÊTE D' ASPIRATION	CABEZA DE ASPIRACIÓN
1	14	1	1	1	1	1	1	036 114 102		ÖLTANK KPL.		OIL TANK COMPLETE	RÉSERVOIR D' HUILE	DÉPÔSITO DE ACEITE
1	15	1	1	1	1	1	1	965 402 491		ÖLSAUGLEITUNG KPL.		SUCTION LINE OIL CPL.	CONDUITE D' ASPIR. HUILE CPL.	CONDUCTO DE ASPIR. ACEITE CPL.
1	16	1	1	1	1	1	1	010 114 063		TANKVERSCHLUß KPL.		TANK PLUG CPL.	BOUCHON RÉSERVOIR CPL.	CIERRE DEPÔSITO CPL.
1	17	1	1	1	1	1	1	010 114 063		TANKVERSCHLUß KPL.		TANK PLUG CPL.	BOUCHON RÉSERVOIR CPL.	CIERRE DEPÔSITO CPL.
1	18	1	1	1	1	1	1	036 112 652		STARTER KPL. BLAU		STARTER ASSY., BLUE	DISPOS. DE DÉMARRAGE CPL. BLEU	DISPOS. DE ARRANQUE CPL. AZUL
1	19	1	1	1	1	1	1	036 112 631		ABDECKKAPPE BLAU		COVER BLUE	COUVERCLE BLEU	CUBIERTA AZUL
1	20	1	1	1	1	1	1	965 404 031		ANWERFGRIFF		STARTER KNOB	POIGNEE DE LANCEMENT	TIRADOR DE ARRANQUE
1	21	1	1	1	1	1	1	036 162 010		SEILTROMMEL		CABLE DRUM	TAMBOUR DE CÂBLE	TAMBOR PARA CORDÓN
1	22	1	1	1	1	1	1	036 163 010		RÜCKHOLFEDER		REWIND SPRING	RESSORT DE RAPPEL	RESORTE RETENCIÓN
1	23	1	1	1	1	1	1	924 805 310		SCHEIBE	ø5,3/15x1	DISC	DISQUE	DISCO DE TOPE
1	24	1	1	1	1	1	1	913 650 154		INNENSTERN-SCHLITZ-SCHRAU BE	5x15	SCREW	VIS	TORNILLO
1	25	1	1	1	1	1	1	965 403 491		SCHWINGUNGSDÄMPFER		RUBBER BUFFER	AMORTISSEUR	AMORTIGUADOR
1	26	1	1	1	1	1	1	036 164 010		ANWERFSEIL	ø3,5 x 880 mm	STARTER ROPE	CÂBLE	CORDÓN DE ARRANQUE
1	27	1	1	1	1	1	1	985 000 155		ANWERFSEIL	ø 3,5 x 100 m	STARTER ROPE	CORDE DE LANCEUR	CUERDA DE ARRANQUE
1	28	4	4	4	4	4	4	913 650 304		INNENSTERN-SCHLITZ SCHRAUBE	5x30	SCREW	VIS	TORNILLO
1	29	1	1	1	1	1	1	036 140 020		ZÜNDER UND POLRAD KPL.		IGNITION AND FLYWHEEL CPL.	ALLUMAGE A. ROUE POLAIRE CPL.	BOBINA CON VOLANTE ENCENDIDO CPL.
1	30	1	1	1	1	1	1	970 311 490		KURZSCHLUßKABEL		SHORT-CIRCUIT CABLE	CÂBLE COURTE-CIRCUIT	CABLE CORTO-CIRCUITO

DCS34, DCS34 , DCS34 ,
DCS4610, DCS4610 ,
DCS4610

1

Starter, Zündelektronik, Tank
Starter, ignition electronics, tank
Dispositif de démarrage, allumage électronique, réservoir
Bobina encendido, dispositivo de arranque, depósito

Makita[®]

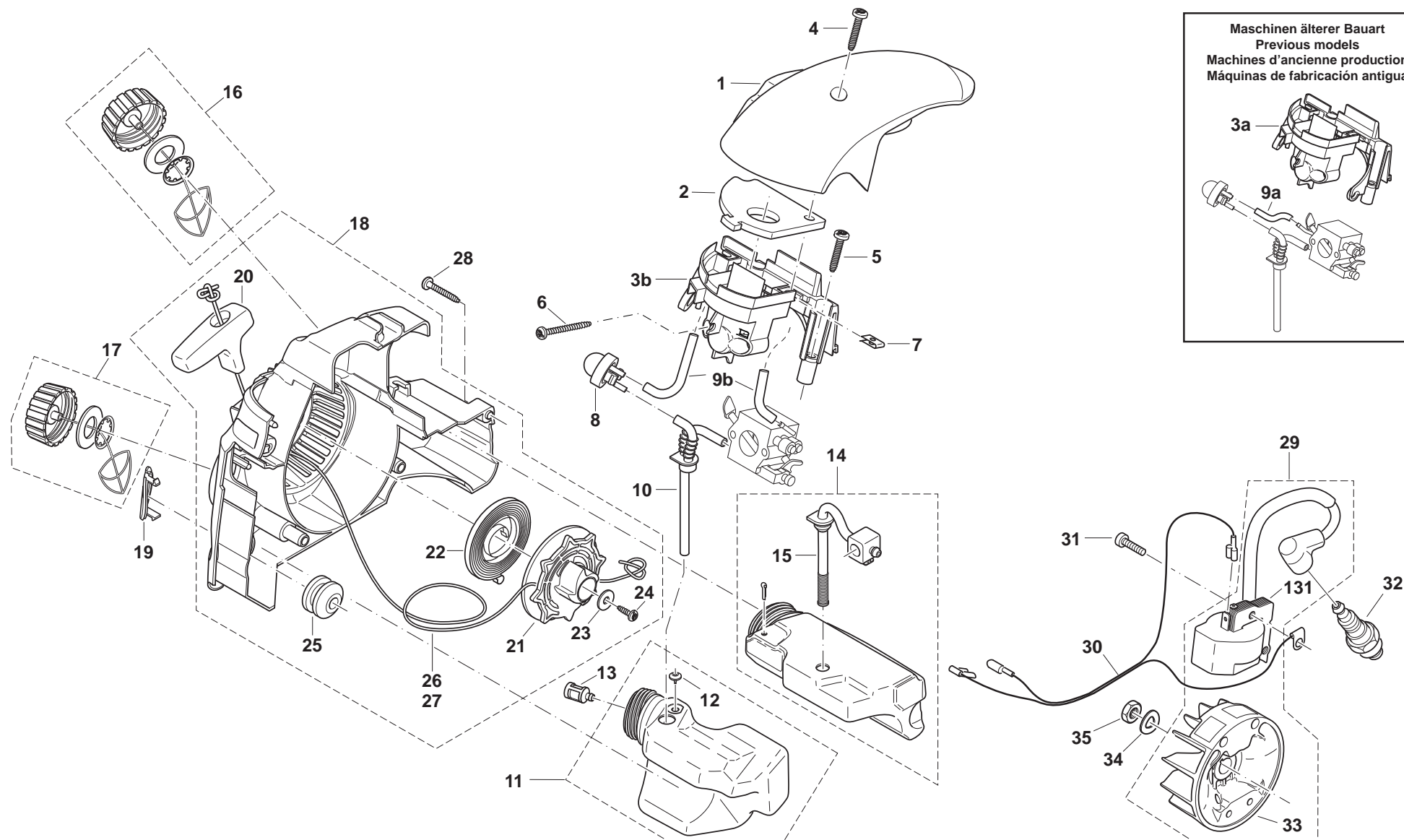

DCS34, DCS34 , DCS34 ,
DCS4610, DCS4610 ,
DCS4610

1

Starter, Zündelektronik, Tank
Starter, ignition electronics, tank
Dispositif de démarrage, allumage électronique, réservoir
Bobina encendido, dispositivo de arranque, depósito



Seite / Page	Pos.	DCS34	DCS34 (AUS,NZ)	DCS34 (USA,CDN)	DCS4610	DCS4610 (AUS,NZ)	DCS4610 (USA)	Teil-Nr. Part No. No. de pièce No. de pieza	Hinweise Notes Renseign. Nota	Bezeichnung	Spezifikation Specification	Description	Désignation	Denominación
1	31	2	2	2	2	2	2	913 340 204		INNENSTERN-SCHLITZ SCHRAUBE	4x20	SCREW	VIS	TORNILLO
1	32	1	1	1	1	1	1	965 603 021		ZÜNDKERZE		SPARK PLUG	BOUGIE	BUJÍA
1	33	1	1	1	1	1	1	036 141 130		POLRAD KPL.		FLYWHEEL CPL.	ROUE POLAIRE CPL.	VOLANTE ENCENDIDO CPL.
1	34	1	1	1	1	1	1	926 208 001		FEDERSCHEIBE	B8 DIN137	SPRING WASHER	RONDELLE ÉLASTIQUE	DISCO AMORTIGUADOR
1	35	1	1	1	1	1	1	920 208 024		6KT-MUTTER	M8x1	HEXAGONAL NUT	ECROU HEXAGONAL	TUERCA HEXAGONAL
1	131	1	1	1	1	1	1	036 143 121		ZÜNDER KPL., BLAU/SCHWARZ		IGNITION ELECTRONIC CPL., BLUE/BLACK	ALLUMAGE ÉLECTR. CPL., BLEU/NOIR	BOBINA ENCENDIDO CPL., AZUL/NEGRO

DCS34, DCS34 , DCS34 ,
DCS4610, DCS4610 ,
DCS4610

2

Griffeinheit, Bügelgriff
Handle, Tubular handle
Poignée, poignée tubulaire
Mango, mango tubular

Makita[®]

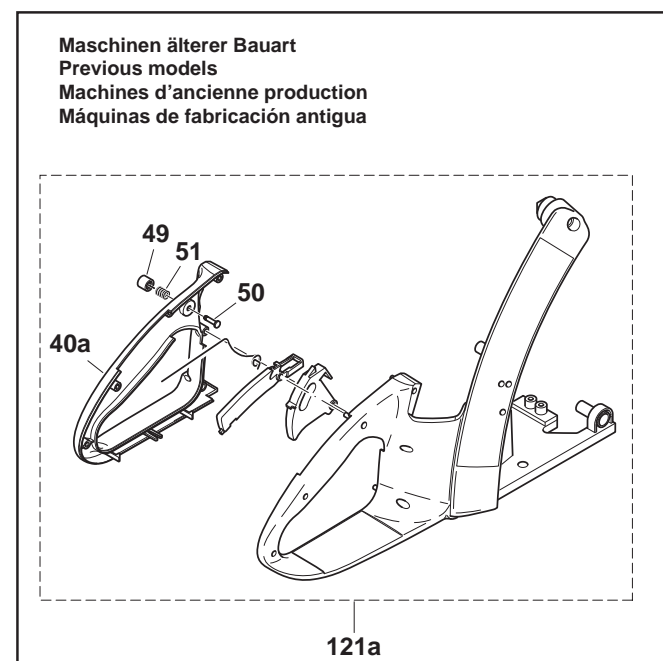
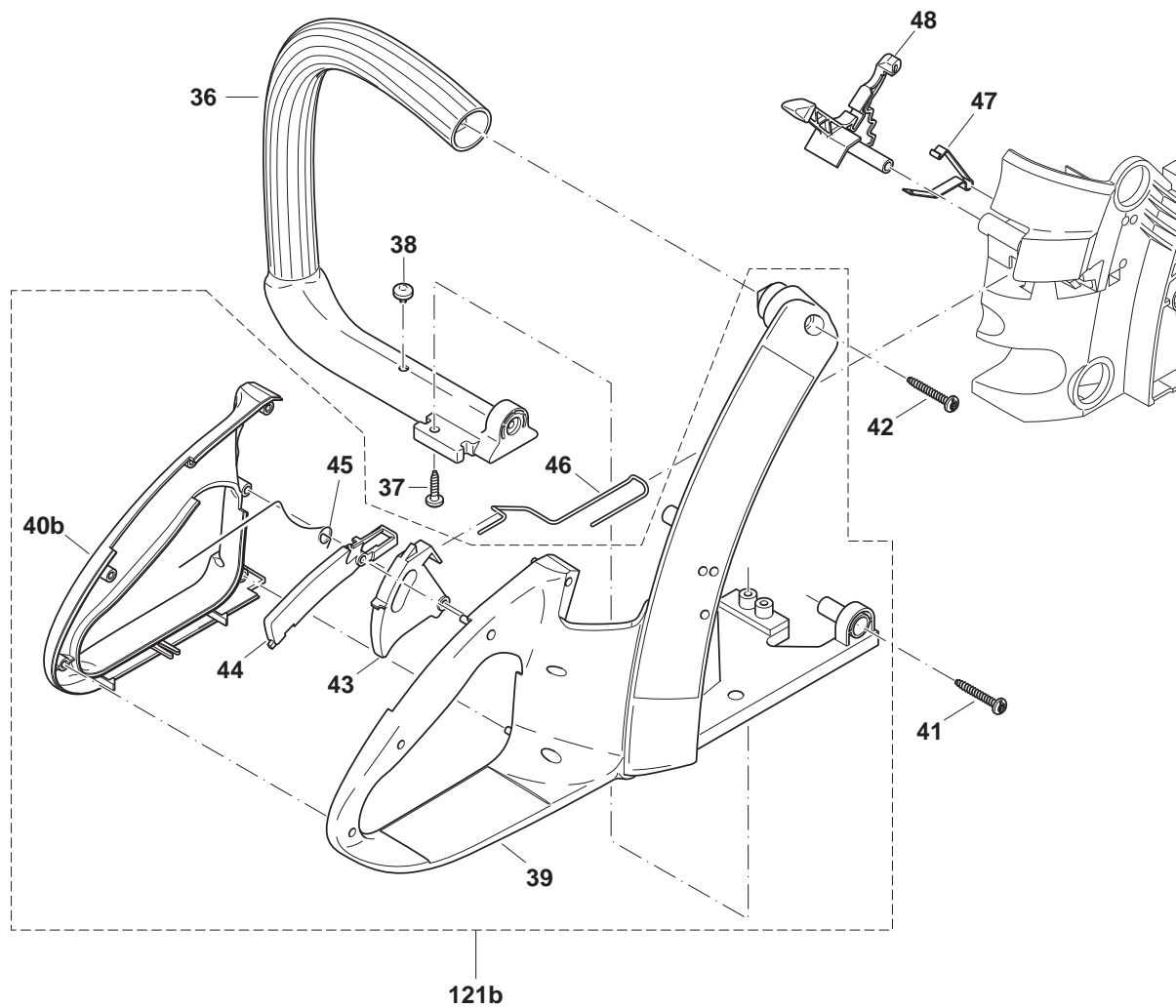

DCS34, DCS34 , DCS34 ,
DCS4610, DCS4610 ,
DCS4610

2

Griffeinheit, Bügelgriff
Handle, Tubular handle
Poignée, poignée tubulaire
Mango, mango tubular



Seite / Page	Pos.	DCS34	DCS34 (AUS,NZ)	DCS34 (USA,CDN)	DCS4610	DCS4610 (AUS,NZ)	DCS4610 (USA)	Teil-Nr. Part No. No. de pièce No. de pieza	Hinweise Notes Renseign. Nota	Bezeichnung	Spezifikation Specification	Description	Désignation	Denominación
2	36	1	1	1	1	1	1	036 310 012		BÜGELGRIFF SCHWARZ		TUBULAR HANDLE BLACK	POIGNÉE TUBULAIRE NOIR	MANGO TUBULAR NEGRO
2	37	1	1	1	1	1	1	913 650 154		INNENSTERN-SCHLITZ-SCHRAUBE	5x15	SCREW	VIS	TORNILLO
2	38	1	1	1	1	1	1	965 402 360		GUMMIPUFFER		RUBBER BUFFER	BUTOIR CAOUTCHOUC	TOPE DE GOMA
2	39	1	1	1	1	1	1	036 117 611		GRIFFEINHEIT BLAU		HANDLE HALF BLUE	DEMI-POIGNÉE BLEU	SEMI-MANGO AZUL
2	40a	1	1	1	1	1	1	036 117 661	=> 2009	GRIFFHÄLFTE BLAU		HANDLE HALF BLUE	DEMI-POIGNÉE BLEU	SEMI-MANGO AZUL
2	40b	1	1	1	1	1	1	036 117 663	2010 =>	GRIFFHÄLFTE BLAU		HANDLE HALF BLUE	DEMI-POIGNÉE BLEU	SEMI-MANGO AZUL
2	41	1	1	1	1	1	1	913 650 304		INNENSTERN-SCHLITZ-SCHRAUBE	5x30	SCREW	VIS	TORNILLO
2	42	1	1	1	1	1	1	913 650 304		INNENSTERN-SCHLITZ-SCHRAUBE	5x30	SCREW	VIS	TORNILLO
2	43	1	1	1	1	1	1	036 117 030		GASHEBEL SCHWARZ		THROTTLE LEVER BLACK	LEVIER D' ACCÉLÉRATION NOIR	ACELERADOR NEGRO
2	44	1	1	1	1	1	1	036 117 040		GASHEBELSPERRE SCHWARZ		CATCH LEVER BLACK	LEVIER DE VERROUILLAGE NOIR	PALANCA TRINCADA NEGRO
2	45	1	1	1	1	1	1	036 117 051		DREHFEDER		SPRING	RESSORT	MUELLE
2	46	1	1	1	1	1	1	036 117 021		GASGESTÄNGE		THROTTLE LINKAGE	TRINGLE D' ACCÉLÉRATION	VARILLA ACELERADOR
2	47	1	1	1	1	1	1	036 155 130		KONTAKTFEDER		CONTACT SPRING	RESSORT DE CONTACT	RESORTE DE CONTACTO
2	48	1	1	1				036 155 020	=> 2009	CHOKEHEBEL	BLACK	CHOKE LEVER	LEVIER DE STARTER	PALANCA ESTRANGULADOR DE AIRE
2	48	1	1	1	1	1	1	036 155 121	2010 =>	CHOKEHEBEL	TAST-STOPP, BLACK	CHOKE LEVER	LEVIER DE STARTER	PALANCA ESTRANGULADOR DE AIRE
2	49	1	1	1	1	1	1	965 451 750	=> 2009	KNOPF FÜR RASTSTIFT SCHWARZ		BUTTON BLACK	BOUTON NOIR	BOTÓN NEGRO
2	50	1	1	1	1	1	1	965 551 150	=> 2009	RASTSTIFT		STOP PIN	GOUILLE D' ARRÊT	PERNO
2	51	1	1	1	1	1	1	965 551 160	=> 2009	DRUCKFEDER		PRESSURE SPRING	RESSORT DE PRESSION	RESORTE DE PRESIÓN
2	121a	1	1	1	1	1	1	036 110 623	=> 2009	GRIFF MIT MOTORTRÄGER KPL. BLAU	BLUE INCL. 87	HANDLE WITH MOTOR SUPPORT CPL.	POIGNÉE PAR SUPPORT DE MOTEUR	MANGO DE SOPORTE DEL MOTOR
2	121b	1	1	1	1	1	1	036 117 602	2010 =>	GRIFFEINHEIT KPL. BLAU		HANDLE CPL. BLUE	POIGNÉE CPL. BLEU	MANGO CPL. AZUL

DCS34, DCS34 , DCS34 ,
DCS4610, DCS4610 ,
DCS4610

3

Zylinder, Kurbelwelle, Schalldämpfer
Cylinder, crankshaft, muffler
Cylindre, vilebrequin, pot d' échappement
Cilindro, cigüeñal, silencioso

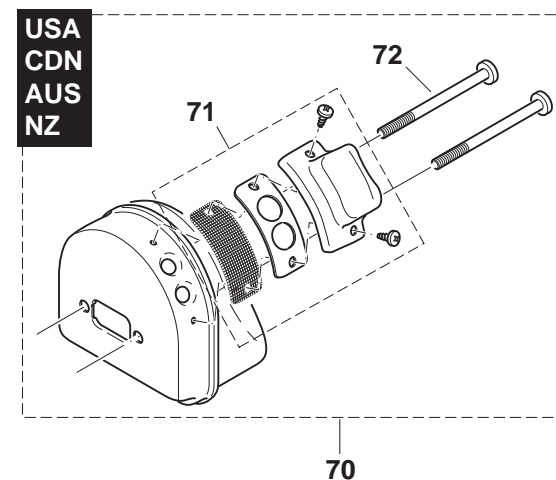
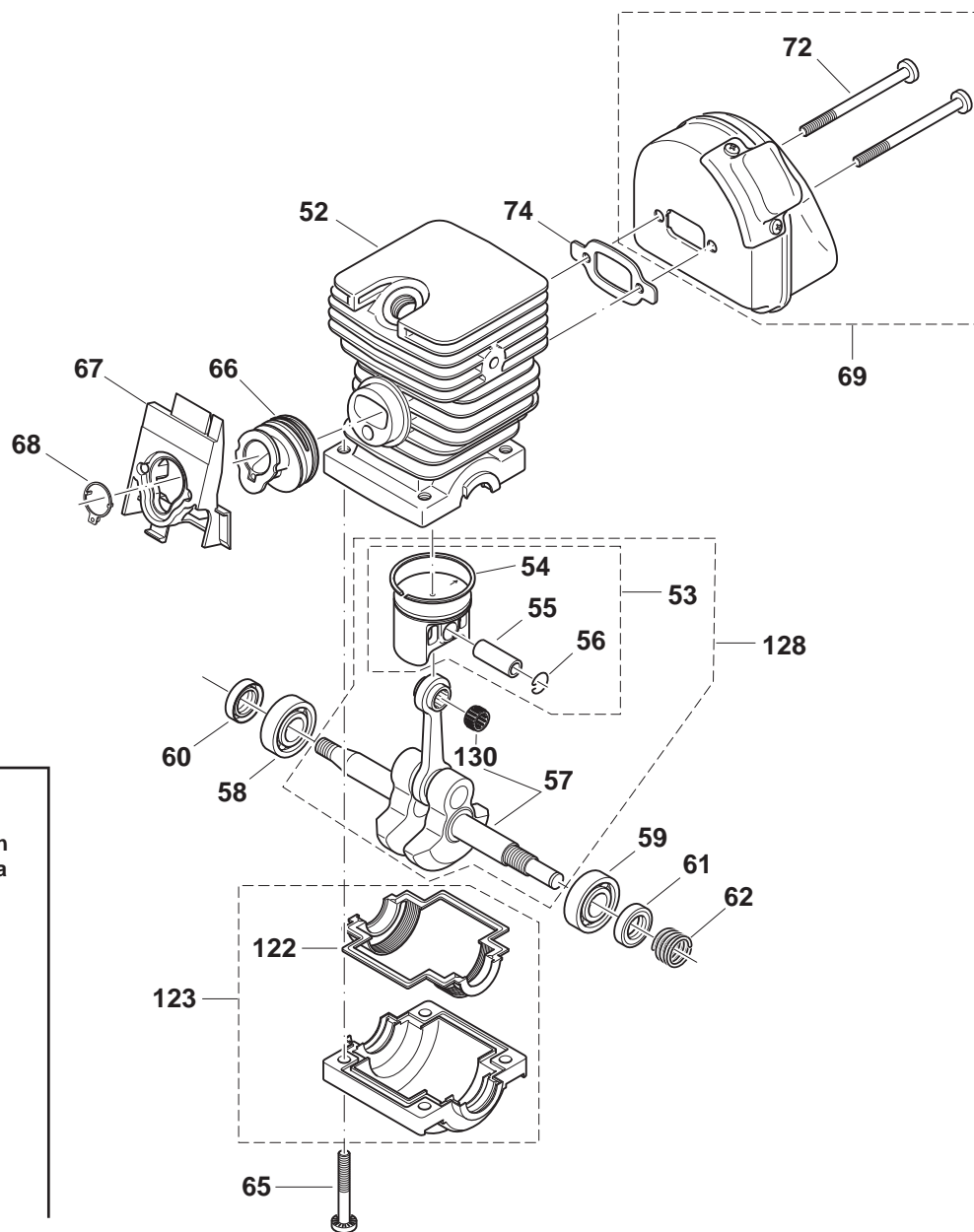

Maschinen älterer Bauart
Previous models
Machines d'ancienne production
Máquinas de fabricación antigua

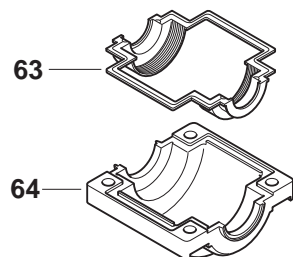

DCS34, DCS34 , DCS34 ,
DCS4610, DCS4610 ,
DCS4610

3

Zylinder, Kurbelwelle, Schalldämpfer
Cylinder, crankshaft, muffler
Cylindre, vilebrequin, pot d' échappement
Cilíndro, cigüeñal, silencioso



Seite / Page	Pos.	DCS34	DCS34 (AUS,NZ)	DCS34 (USA,CDN)	DCS4610	DCS4610 (AUS,NZ)	DCS4610 (USA)	Teil-Nr. Part No. No. de pièce No. de pieza	Hinweise Notes Renseign. Nota	Bezeichnung	Spezifikation Specification	Description	Désignation	Denominación
3	52	1	1	1				036 131 015		ZYLINDER	33 cm3	CYLINDER	CYLINDRE	CILÍNDRO
3	52				1	1	1	037 131 010		ZYLINDER	45 ccm	CYLINDER	CYLINDRE	CILÍNDRO
3	53	1	1	1				021 132 111		KOLBEN KPL.	ø 37mm	PISTON ASSY.	PISTON CPL.	PISTÓN CPL.
3	53				1	1	1	037 132 110		KOLBEN KPL.	ø 43mm	PISTON CPL.	PISTON CPL.	PISTÓN CPL.
3	54	1	1	1				021 132 030		KOLBENRING	ø 37mm	PISTON RING	SEGMENT DE PISTON	SEGMENT DE PISTÓN
3	54				1	1	1	037 132 020		KOLBENRING	ø 43mm	PISTON RING	SEGMENT DE PISTON	SEGMENT DE PISTÓN
3	55	1	1	1				021 132 020		KOLBENBOLZEN		PISTON PIN	AXE DE PISTON	AXE DE PISTÓN
3	55				1	1	1	195 132 030		KOLBENBOLZEN		PISTON PIN	AXE DE PISTON	PERNO DE PISTÓN
3	56	2	2	2	2	2	2	108 132 050		SPRENGRING		SPRING RING	ANNEAU RESSORT	ANILO ELASTICO
3	57	1	1	1	1	1	1	036 120 310		KURBELWELLE MIT NADELLAGER KPL.		CRANKSHAFT ASSY.	VILEBREQUIN CPL.	CIGÜEÑAL CPL.
3	58	1	1	1	1	1	1	960 102 131		KUGELLAGER	6201	BALL BEARING	ROULEMENT À BILLES	RODAMIENTO DE BOLAS
3	59	1	1	1	1	1	1	960 102 131		KUGELLAGER	6201	BALL BEARING	ROULEMENT À BILLES	RODAMIENTO DE BOLAS
3	60	1	1	1	1	1	1	962 900 057		RADIALDICHRING		RADIAL RING	JOINT RADIAL	JUNTA RADIAL
3	61	1	1	1	1	1	1	962 900 057		RADIALDICHRING		RADIAL RING	JOINT RADIAL	JUNTA RADIAL
3	62	1	1	1	1	1	1	036 245 020		ANTRIEBSSCHNECKE		WORM	VIS SANS FIN	TORNILLO SIN FIN
3	63	1	1	1				965 531 010		DICHTUNG FÜR KURBELGEHÄUSE		GASKET	JOINT	JUNTA
3	64	1	1	1				036 111 010		KURBELGEHÄUSE-UNTERTEIL		CRANKCASE LOWER PART	CARTER-VILEBR. PARTIE INFÉRIEURE	CÁRTER CIGÜEÑAL PARTE INFERIOR
3	65	4	4	4	4	4	4	913 350 404		INNENSTERN-SCHLITZ-SCHRAUB E	5x40/20	SCREW	VIS	TORNILLO
3	66	1	1	1	1	1	1	036 131 023		ANSAUGSCHLAUCH		SUCTION HOSE	TUYAU D' ASPIRATION	TUBO DE ASPIRACIÓN
3	67	1	1	1	1	1	1	036 171 020		VERGASERSCHELLE		CLAMP	COLLIER	ABRAZADERA
3	68	1	1	1	1	1	1	036 131 030		EINSATZ FÜR ANSAUGSCHLAUCH		INSERT FOR SUCTION HOSE	PIÈCE P. TUYAU D' ASPIRATION	SUPLEMENTO P. TUBO DE ASP.
3	69	1			1			036 174 211		SCHALLDÄMPFER KPL.		MUFFLER CPL.	POT D' ÉCHAPPEMENT CPL.	SILENCIADOR CPL.
3	70		1	1		1	1	036 174 311		SCHALLDÄMPFER KPL.	USA, AUS, NZ	SPARK ARRESTER MUFFLER ASSY.	POT D' ÉCHAPPEMENT	SILENCIADOR
3	71		1	1		1	1	036 174 201		FUNKENSCHUTZSIEB KPL.		SPARK ARRESTER SCREEN CPL.	TAMIS CPL.	TAMIZ CPL.
3	72	2	2	2	2	2	2	913 350 654		INNENSTERN-SCHLITZ-SCHRAUB E	5x65	SCREW	VIS	TORNILLO
3	74	1	1	1	1	1	1	965 522 033		DICHTUNG		GASKET	JOINT	JUNTA
3	122	1	1	1	1	1	1	965 531 020		DICHTUNG FÜR KURBELGEHÄUSE		GASKET	JOINT	JUNTA
3	123	1	1	1	1	1	1	965 531 030		KURBELGEHÄUSE-UNTERTEIL KPL.		CRANKCASE LOWER PART CPL.	CARTER-VILEBR. PARTIE INFÉRIEURE CPL.	CÁRTER CIGÜEÑAL PARTE INFERIOR CPL.
3	128	1	1	1				036 120 110		KURBELWELLE MIT KOLBEN KPL.		CRANKSHAFT AND PISTON ASSY.	VILEBREQUIN AVEC PISTON CPL.	CIGÜEÑAL CON PISTON CPL.
3	130	1	1	1	1	1	1	962 211 007		NADELKÄFIG	K9X12X11,5	NEEDLE CAGE	CAGE A AIGUILLES	JAULA DE AGUJAS

DCS34, DCS34 , DCS34 ,
DCS4610, DCS4610 ,
DCS4610

4

Ölpumpe, Kettenbremse
Oil pump, chain brake
Pompe à huile, frein de chaîne
Bomba de aceite, freno de cadena

Makita[®]

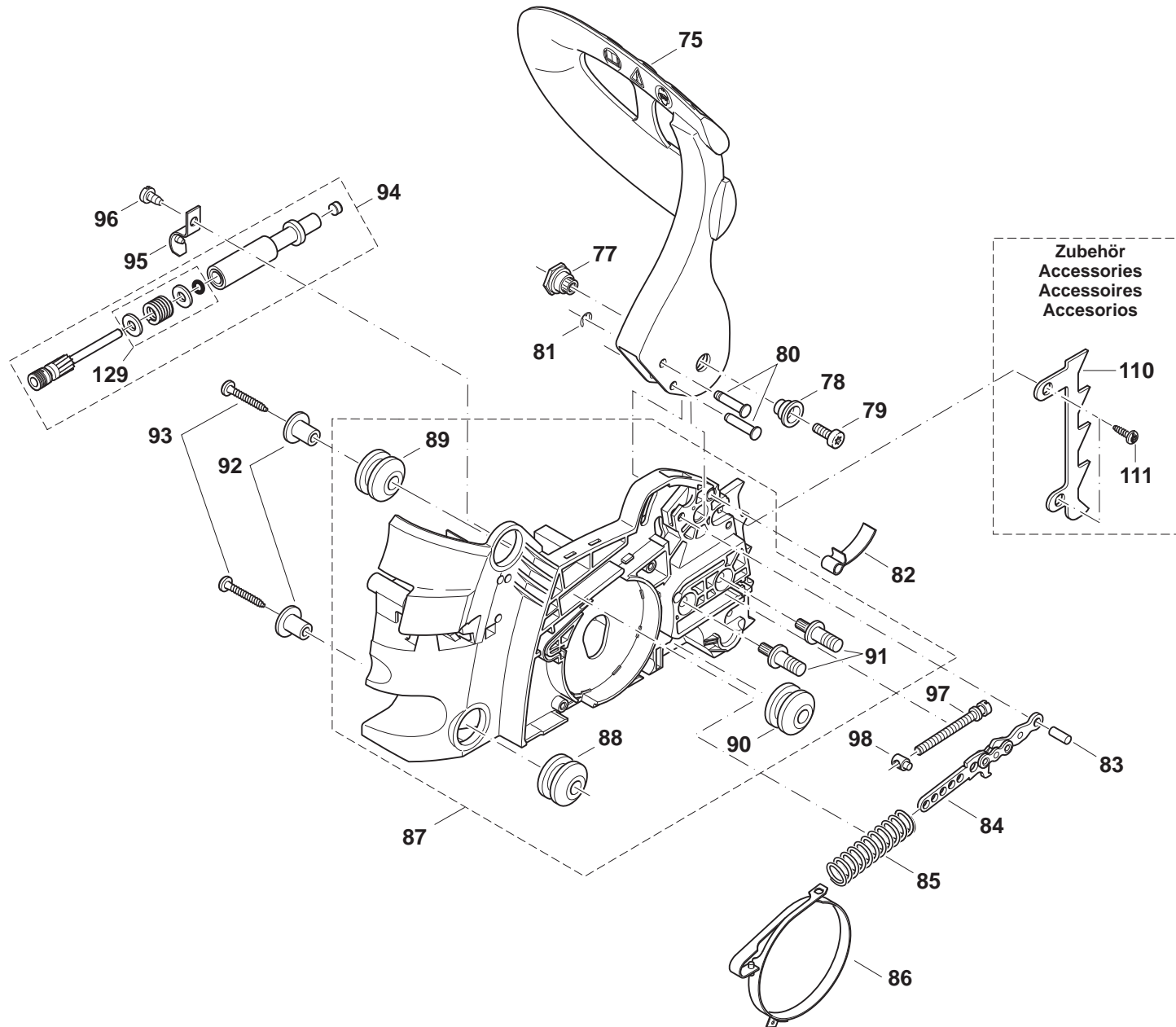

DCS34, DCS34 , DCS34 ,
DCS4610, DCS4610 ,
DCS4610

4

Ölpumpe, Kettenbremse
Oil pump, chain brake
Pompe à huile, frein de chaîne
Bomba de aceite, freno de cadena



Seite / Page	Pos.	DCS34	DCS34 (AUS,NZ)	DCS34 (USA,CDN)	DCS4610	DCS4610 (AUS,NZ)	DCS4610 (USA)	Teil-Nr. Part No. No. de pièce No. de pieza	Hinweise Notes Renseign. Nota	Bezeichnung	Spezifikation Specification	Description	Désignation	Denominación
4	75	1	1	1	1	1	1	036 213 051		HANDSCHUTZ SCHWARZ		HAND GUARD BLACK	PROTÈGE-MAIN NOIR	PROTECTOR DE MANO NEGRO
4	77	1	1	1	1	1	1	036 213 081		GEWINDEBUCHSE		BUSH	DOUILLE	CASQUILLO ROSCADO
4	78	1	1	1	1	1	1	036 213 070		LAGERBUCHSE		BUSH	DOUILLE	FORRO DE COJINETE
4	79	1	1	1	1	1	1	908 005 165		SCHRAUBE	M5x16	SCREW	VIS	TORNILLO
4	80	2	2	2	2	2	2	934 150 200		BOLZEN MIT KOPF A	5x22	BOLT	BOULON	BULÓN
4	81	1	1	1	1	1	1	927 304 000		SICHERUNGSSSCHEIBE		SAFETY WASHER	RONDELLE SÉCURITÉ	ARANDELA SEGURIDAD
4	82	1	1	1	1	1	1	036 213 030		FEDER FÜR HANDSCHUTZ		SPRING	RESSORT	MUELLE
4	83	1	1	1	1	1	1	962 650 128		NADELROLLE		CYLINDRICAL PIN	GOUPILLE CYLINDRIQUE	PRISIONERO
4	84	1	1	1	1	1	1	036 213 020		BREMSBANDHALTER KPL.		BRAKE SPRING HOLDER CPL.	SUPPORT DE RESSORT DE FREIN CPL.	SOPORTE DE CINTA DE FRENO CPL.
4	85	1	1	1	1	1	1	028 213 201		SPEICHERFEDER		SPRING	RESSORT	RESORTE
4	86	1	1	1	1	1	1	028 213 501		BREMSBAND		BRAKE SPRING	FREIN	CINTA DE FRENO
4	87	1	1	1	1	1	1	036 110 606		MOTORTRÄGER KPL. BLAU		MOTOR HOUSING, CPL., BLUE	SUPPORT DE MOTEUR CPL. BLEU	SOPORTE DE MOTOR CPL. AZUL
4	88	1	1	1	1	1	1	965 403 491		SCHWINGUNGSDÄMPFER		RUBBER BUFFER	AMORTISSEUR	AMORTIGUADOR
4	89	1	1	1	1	1	1	965 403 491		SCHWINGUNGSDÄMPFER		RUBBER BUFFER	AMORTISSEUR	AMORTIGUADOR
4	90	1	1	1	1	1	1	965 403 491		SCHWINGUNGSDÄMPFER		RUBBER BUFFER	AMORTISSEUR	AMORTIGUADOR
4	91	2	2	2	2	2	2	036 110 021		SCHIENENBOLZEN		BOLT	BOULON	BULÓN
4	92	2	2	2	2	2	2	036 114 020		BEFESTIGUNGSBUCHSE		FIXING BUSH	DOUILLE FIXATION	CASQUILLO DE AJUSTE
4	93	2	2	2	2	2	2	913 650 304		INNENSTERN-SCHLITZ SCHRAUBE	5x30	SCREW	VIS	TORNILLO
4	94	1	1	1	1	1	1	021 245 007		ÖLPUMPE KPL.		OIL PUMP ASSY.	POMPE À HUILE CPL.	BOMBA DE ACEITE CPL.
4	95	1	1	1	1	1	1	203 245 002		HALTER FÜR ÖLPUMPE		HOLDER FOR OIL PUMP	CRAMPON P. POMPE À HUILE	EMPUÑADURA P. BOMBA
4	96	1	1	1	1	1	1	913 335 060		KREUZSCHLITZ-SCHRAUBE	3,5x6,5	SCREW	VIS	TORNILLO
4	97	1	1	1	1	1	1	036 213 090		SPANNSCHRAUBE		STRAINING SCREW	VI DE TENSION	TORNILLO
4	98	1	1	1	1	1	1	001 213 042		MUTTER MIT ZAPFEN		NUT WITH PIVOT	ECROU AVEC PIVOT	TUERCA CON ESPIGA
4	110	1	1	1	1	1	1	205 250 011	ACC.	ZACKENLEISTE		SPIKE BAR	BARRE DENTÉE	BARRA DENTADA
4	111	2	2	2	2	2	2	913 650 154	ACC.	INNENSTERN-SCHLITZ-SCHRAUBE	5x15	SCREW	VIS	TORNILLO
4	129	1	1	1	1	1	1	021 245 281		REP.-SATZ ÖLPUMPE		REPAIR KIT OIL PUMP	JEU DE RÉP. POMPE À HUILE	JUEGO DE REP. BOMBA DE ACEITE

DCS34, DCS34 , DCS34 ,
DCS4610, DCS4610 ,
DCS4610

5

Kupplung
Clutch
Embrayage
Embrague



Maschinen älterer Bauart
Previous models
Machines d'ancienne production
Máquinas de fabricación antigua

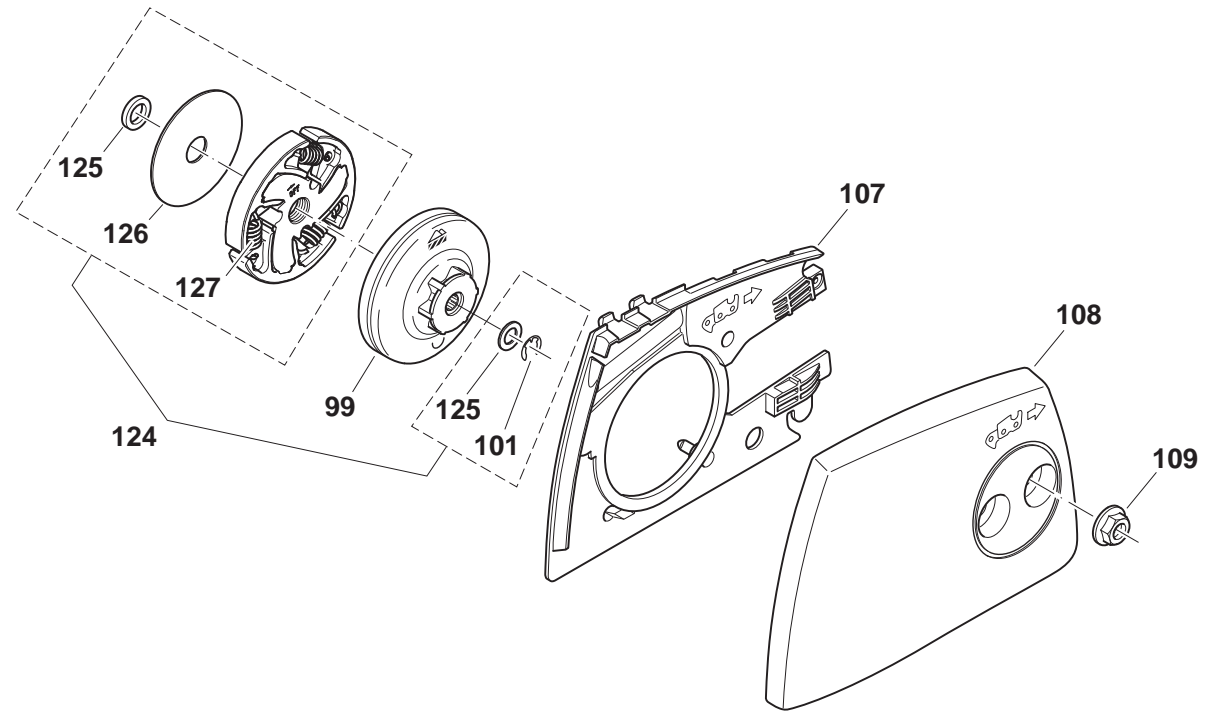
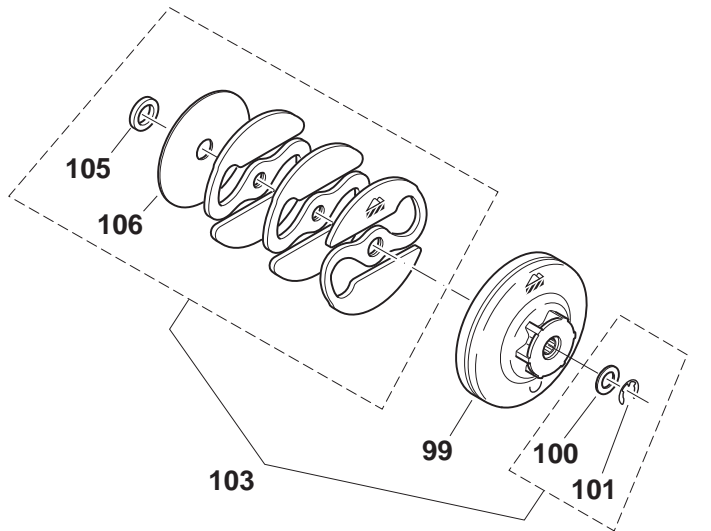

DCS34, DCS34 , DCS34 ,
DCS4610, DCS4610 ,
DCS4610

5

Kupplung
Clutch
Embrayage
Embrague



Seite / Page	Pos.	DCS34	DCS34 (AUS,NZ)	DCS34 (USA,CDN)	DCS4610	DCS4610 (AUS,NZ)	DCS4610 (USA)	Teil-Nr. Part No. No. de pièce No. de pieza	Hinweise Notes Renseign. Nota	Bezeichnung	Spezifikation Specification	Description	Désignation	Denominación
5	99	1	1	1	1	1	1	036 223 115		KUPPLUNGSTROMMEL KPL.	3/8"	CLUTCH DRUM CPL.	TAMBOUR CPL.	TAMBOR CPL.
5	100	1	1	1				900 006 065		PASSSCHEIBE	ø8/14x1	WASHER	RONDELLE	ARANDELA
5	101	1	1	1	1	1	1	927 306 000		SICHERUNGSSCHEIBE		SAFETY WASHER	RONDELLE SÉCURITÉ	ARANDELA SEGURIDAD
5	103	1	1	1				036 181 110		KUPPLUNGSLAMELLEN (SATZ)		CLUTCH (SET)	EMBAYAGE (JEU)	EMBRAGUE (JUEGO)
5	105	1	1	1				036 224 010		DISTANZSCHEIBE	ø10/16x2,5	WASHER	RONDELLE	ARANDELA
5	106	1	1	1				027 182 031		FÜHRUNGSSCHEIBE		GUIDE DISC	DISQUE DE GUIDAGE	DISCO DE GUÍA
5	107	1	1	1	1	1	1	036 213 041		ABDECKPLATTE		COVER PLATE	TOLE DE RECOUVREMENT	CHAPA PROTECTORA
5	108	1	1	1	1	1	1	036 213 652		KETTENRADSCHUTZ KPL. BLAU		SPROCKET GUARD CPL. BLUE	PROTÈGE-PIGNON CPL. BLEU	PROTECTOR DE PIÑON CPL. AZUL
5	109	2	2	2	2	2	2	923 208 004		6KT-MUTTER	M8	HAXAGONAL NUT	ECROU HEXAGONAL	TUERCA HEXAGONAL
5	124	1	1	1	1	1	1	036 180 210		KUPPLUNG KPL.		CLUTCH CPL.	EMBAYAGE CPL.	EMBRAGUE CPL.
5	125	1	1	1	1	1	1	036 224 050		DISTANZ-, PASSSCHEIBE SATZ		WASHER SET	RONDELLE JEU	ARANDELA JUEGO
5	126	1	1	1	1	1	1	001 182 062		FÜHRUNGSSCHEIBE		GUIDE DISC	DISQUE DE GUIDAGE	ARANDELA
5	127	3	3	3	3	3	3	181 184 010		ZUGFEDER FÜR KUPPLUNG		SPRING	RESSORT	RESORTE

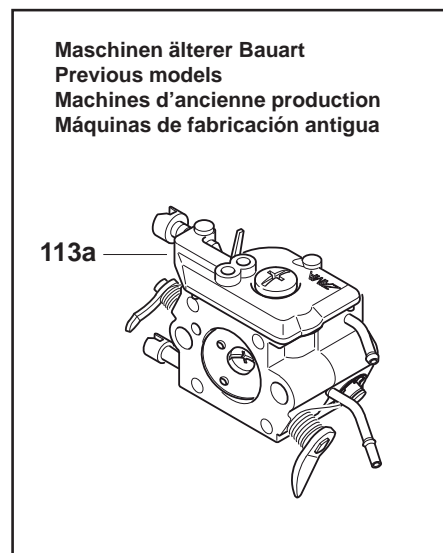
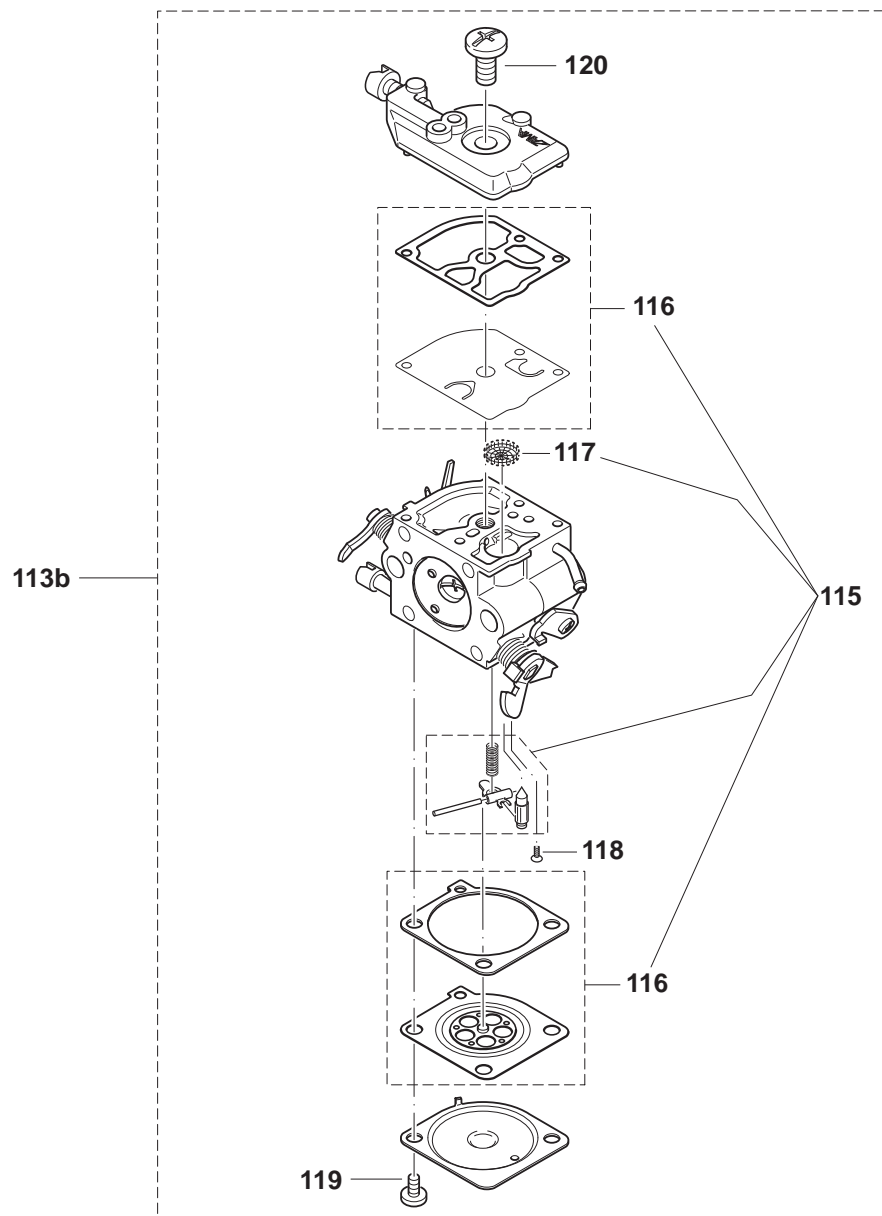

DCS34, DCS34 , DCS34 ,
DCS4610, DCS4610 ,
DCS4610

6

Vergaser
Carburetor
Carburateur
Carburador



Seite / Page	Pos.	DCS34	DCS34 (AUS,NZ)	DCS34 (USA,CDN)	DCS4610	DCS4610 (AUS,NZ)	DCS4610 (USA)	Teil-Nr. Part No. No. de pièce No. de pieza	Hinweise Notes Renseign. Nota	Bezeichnung	Spezifikation Specification	Description	Désignation	Denominación
6	113a	1	1	1	1	1	1	036 153 014	=> 2009	VERGASER KPL.	DM9B Primer	CARBURETOR CPL.	CARBURATEUR CPL.	CARBURADOR CPL.
6	113a			1			1	036 153 150	USA => 2009	VERGASER KPL.	Primer LC	CARBURETOR CPL.	CARBURATEUR CPL.	CARBURADOR CPL.
6	113b	1	1	1	1	1	1	036 153 016	2010 =>	VERGASER KPL.	DM15 Primer	CARBURETOR CPL.	CARBURATEUR CPL.	CARBURADOR CPL.
6	115	1	1	1	1	1	1	036 153 100		REPARATURSATZ		REPAIR KIT	JEU DE RÉPARATION	JUEGO DE REPARAR
6	116	1	1	1	1	1	1	036 153 110		DICHTUNG & MEMBRAN SATZ		GASKET & DIAPHRAGM KIT	JEU DE JOINT & MEMBRANE	JUEGA JUNTA & MEMBRANA
6	117	1	1	1	1	1	1	036 153 040		SIEB		SCREEN	TAMIS	TAMIZ
6	118	1	1	1	1	1	1	028 153 200		SCHRAUBE		SCREW	VIS	TORNILLO
6	119	2	2	2	2	2	2	001 153 020		SCHRAUBE FÜR REGELDECKEL		SCREW	VIS	TORNILLO
6	120	1	1	1	1	1	1	038 153 360		SCHRAUBE		SCREW	VIS	TORNILLO

DCS34, DCS34 , DCS34 ,
DCS4610, DCS4610 ,
DCS4610

7

Sägeschienen, Sägeketten, Werkzeug
Guide bars, saw chains, tools
Guide-chaîne, chaînes, outils
Rieles guía, cadenas sierra, herramientas



3/8"

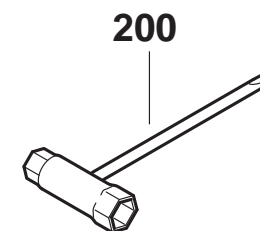
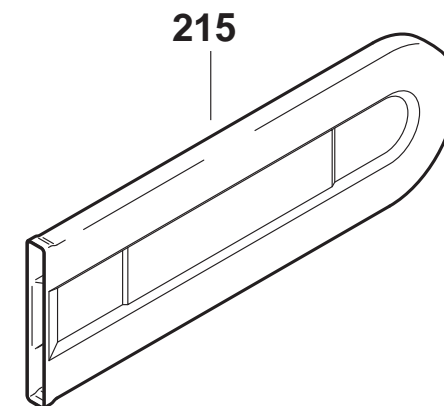
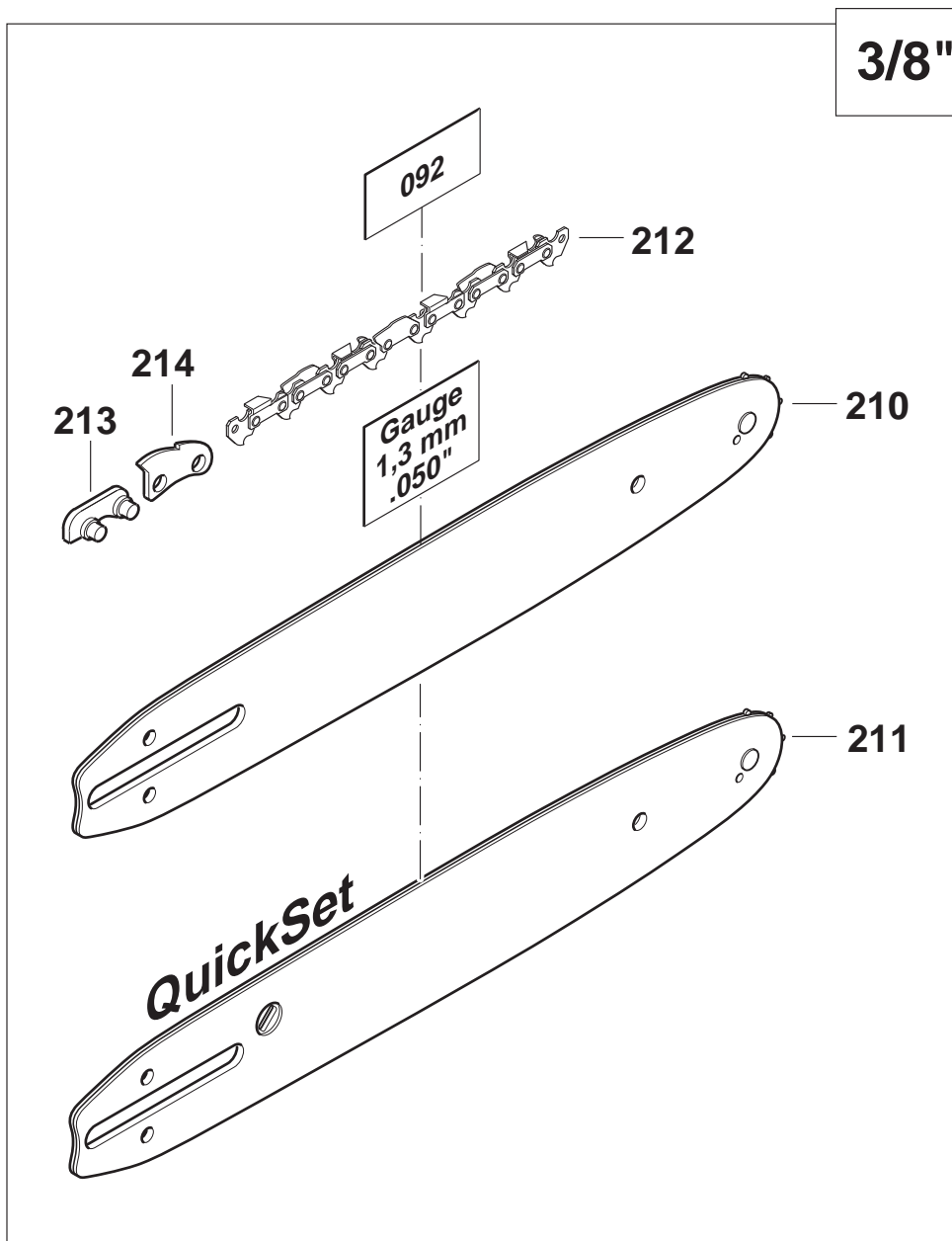

DCS34, DCS34 , DCS34 ,
DCS4610, DCS4610 ,
DCS4610

7

Sägeschienen, Sägeketten, Werkzeug
Guide bars, saw chains, tools
Guide-chaîne, chaînes, outils
Rieles guía, cadenas sierra, herramientas



Seite / Page	Pos.	DCS34	DCS34 (AUS,NZ)	DCS34 (USA,CDN)	DCS4610	DCS4610 (AUS,NZ)	DCS4610 (USA)	Teil-Nr. Part No. No. de pièce No. de pieza	Hinweise Notes Renseign. Nota	Bezeichnung	Spezifikation Specification	Description	Désignation	Denominación
7	200	1	1	1	1	1	1	941 719 131		KOMBISCHLÜSSEL	SW 13/19	UNIVERSAL WRENCH	CLÉ COMBINÉE	LLAVE DE BUJIA
7	210	1	1	1	1	1	1	442 035 661		STERNSCHIENE	3/8" .050" 35cm-14"	SPROCKET NOSE BAR	GUIDE À ÉTOILE	GUÍA CON ESTRELLA
7	210	1	1	1	1	1	1	442 040 661		STERNSCHIENE	3/8" .050" 40cm-16"	SPROCKET NOSE BAR	GUIDE À ÉTOILE	GUÍA CON ESTRELLA
7	211	1	1	1				442 035 061		STERNSCHIENE QUICKSET	3/8" .050" 35cm-14"	SPROCKET NOSE BAR	GUIDE À ÉTOILE	GUÍA CON ESTRELLA
7	211	1	1	1				442 040 061		STERNSCHIENE QUICKSET	3/8" .050" 40cm-16"	SPROCKET NOSE BAR	GUIDE À ÉTOILE	GUÍA CON ESTRELLA
7	212	1	1	1	1	1	1	528 092 652		SÄGEKETTE	3/8" .050" 35cm-14"	SAW CHAIN	CHAÎNE	CADENA
7	212	1	1	1	1	1	1	528 092 656		SÄGEKETTE	3/8" .050" 40cm-16"	SAW CHAIN	CHAÎNE	CADENA
7	213	1	1	1	1	1	1	558 092 010		AUSSENLASCHE MIT NIET	3/8" .050"	TIE STRAP WITH RIVETS	ECLISSE EXTER. A. RIVETS	TIRA EXTER. CON REMACHE
7	214	1	1	1	1	1	1	558 092 000		SICHERHEITSLASCHE	3/8" .050"	SAFETY TIE STRAP	ECLISSE DE SÉCURITÉ	TIRA SEGURIDAD
7	215	1	1	1	1	1	1	952 010 630		KETTENSCHUTZ	30-35 cm	CHAIN PROTECTION	PROTECTION CHAÎNE	PROTECTOR DE CADENA
7	215	1	1	1	1	1	1	952 010 640		KETTENSCHUTZ	40 cm	CHAIN PROTECTION	PROTECTION CHAÎNE	PROTECTOR DE CADENA

DCS34, DCS34 , DCS34 ,
DCS4610, DCS4610 ,
DCS4610



	Zeichenerklärung	Key to symbols	Légende	Explicación de símbolos
=> 1999999 2000000 => 2003.04 => TI 2003/07 Acc. = { m Corr.	Produktion bis Serien-Nr. Neues Teil ab Serien-Nr. Neues Teil ab Jahr / Monat Siehe Technische Information Jahr / Nr. Zubehör (nicht im Lieferumfang) Keine Serienausführung, jedoch verwendbar Beinhaltet Positions-Nr. Meterware Druckfehlerberichtigung	Production to serial number New part from serial number New part from Year / Month See Technical Information Year / No. Accessories (not included in the delivery inventory) No standard execution, may be used Contains item number Sold by the meter Error correction	Production jusqu'à n° de série Nouvelle pièce à partir du n° de série Nouvelle pièce à partir de année / mois Voir information technique année / n° Accessoires (non compris dans la livraison) Aucune exécut. en série, cependant utilisable contient n° de numéro Au mètre Rectification d'erreurs	Producción hasta N° de serie Pieza nueva a partir de N° de serie Pieza nueva a partir de año / mes Véase inform. técnico año / N° Accesorios (no incluido en la extensión del suministro) No es de serie, pero sirve Contiene pos N° Por metro Fe de erratas
	Änderungen vorbehalten	Specifications subject to change without notice	Changements sans préavis	Mejoras constructivas sin previo aviso