



# Operating Instructions and Parts Manual Manual Cold Saws

Models CS-275, CS-315



*model CS-275-1 shown*

**JET**  
427 New Sanford Road  
LaVergne, Tennessee 37086  
Ph.: 800-274-6848  
[www.jettools.com](http://www.jettools.com)

**Part No. M-414226**  
Revision D 01/2016  
Copyright © 2016 JET

16.1.1 CS-275 Cold Saw (Machine Assembly) – Exploded View

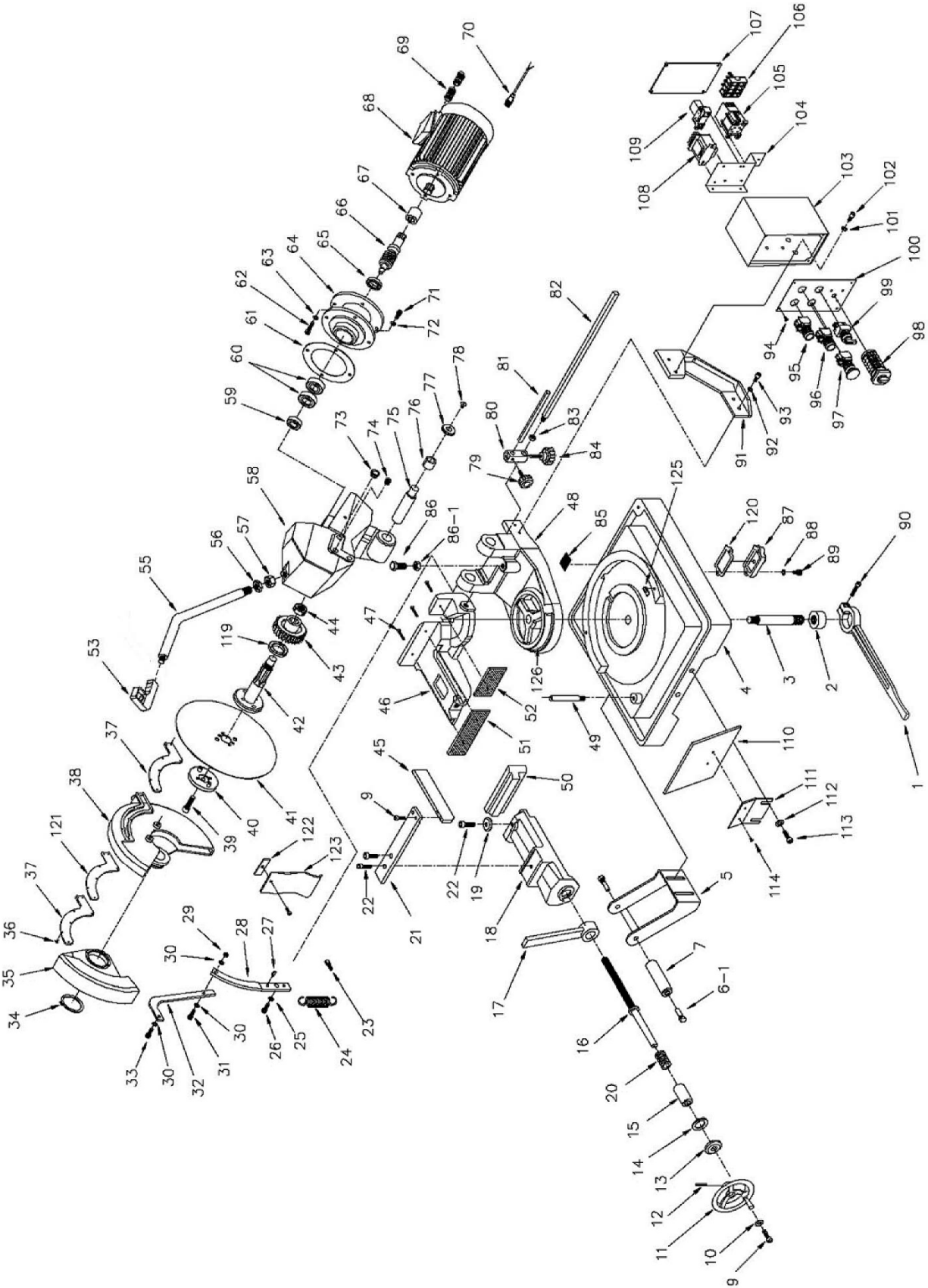

## 16.1.2 CS-275 Cold Saw (Machine Assembly) – Parts List

Index No.	Part No.	Description	Size	Qty
1	CS275-1G	Lock Handle		1
2	CS275-2	Lock Nut		1
3	CS275-3	Shaft		1
4	CS275-4G	Machine Base		1
5	CS275-5	Roller Bracket		1
6-1	TS-1492021	Hex Cap Screw	M12x30	2
7	CS275-7	Roller		1
9	TS-1504041	Socket Head Cap Screw	M8x20	3
10	TS-0680031	Flat Washer	5/16"	1
11	CS275-11	Hand Wheel		1
12	CS275-12	Pin		1
13	CS275-13	Bearing Bushing		1
14	CS275-14	Bearing		1
15	CS275-15	Bushing		1
16	CS275-16	Lead Screw		1
17	CS275-17	Lock Handle		1
18	CS275-18	Vise, Moveable		1
19	CS275-19	Washer		1
20	CS275-20	Spring		1
21	CS275-21	Plate		1
22	TS-1506021	Socket Head Cap Screw	M12x25	3
23	CS275-23	Hex Screw	M10x30	1
24	CS275-24	Spring		1
25	TS-1550061	Flat Washer	M8	1
26	TS-1504041	Socket Head Cap Screw	M8x20	1
27	CS275-27	Pin	5x12	1
28	CS275-28	Switching Plate		1
29	TS-1540061	Hex Nut	M8	1
30	TS-1550061	Flat Washer	M8	3
31	TS-1504051	Socket Head Cap Screw	M8x25	1
32	CS275-32	Switching Handle		1
33	TS-1503021	Socket Head Cap Screw	M6x10	1
34	CS275-34	Retaining Ring	S-60	1
35	CS275-35	Blade Shield		1
36	TS-2245102	Button Head Socket Screw	M5x10	14
37	CS275-37	Plate		2
38	CS275-38G	Blade Cover		1
39	CS275-39	Socket Head Cap Screw (left hand thread)	M12x35LH	1
40	CS275-40	Flange		1
41	CS275-41	Saw Blade		1
42	CS275-42	Spindle		1
43	CS275-43	Worm Gear		1
44	CS275-44	Lock Nut		1
45	CS275-45	Stop		1
46	CS275-46	Vise, Stationary		1
47	TS-1502061	Socket Head Cap Screw	M5x25	3
48	CS275-48G	Base Swing Arm		1
49	CS275-49	Support Rod		1
50	CS275-50	Vise Jaw Insert		1
51	CS275-51	Serrated Jaw Insert		1
52	CS275-52	Small Serrated Jaw Insert		1
53	CS275-53	Handle Grip with Trigger Switch		1
	CS275-53N	Handle Grip with Trigger Switch (s/n 1312XXXX and higher)		1
55	CS275-55	Handle		1
	CS275-55N	Handle (s/n 1312XXXX and higher)		1
56	CS275-56	Nut		1
57	TS-2310201	Hex Nut	M20	1
58	CS275-58G	Machine Head		1
59	BB-6301ZZ	Ball Bearing	6301ZZ	1

Index No.	Part No.	Description	Size	Qty
60	BB-6205ZZ	Ball Bearing	6205ZZ	2
61	CS275-61	Rubber Gasket		1
62	TS-1490031	Hex Cap Screw	M8x20	4
63	TS-0680031	Flat Washer	5/16"	4
64	CS275-64G	Flange		1
65	CS275-65	Oil Seal	25x45x10	1
66	CS275-66	Worm Shaft		1
67	CS275-67	Coupling		1
68	CS275-68	Motor	1.5HP, 220V, 3PH	1
	CS275-68-1	Motor	1.5HP, 115/230V, 1PH	1
69	CS275-69	Wire Terminal Clamp		4
70	CS275-70	Control Wire		1
71	TS-1490031	Hex Cap Screw	M8x20	4
72	TS-0680031	Flat Washer	5/16"	4
73	CS275-73	Oil Plug	1/2" PT	1
74	TS-0271031	Socket Set Screw	3/8"-16x3/8	2
75	CS275-75	Shaft		1
76	CS275-76	Bushing		1
77	CS275-77	Cover		1
78	TS-1504031	Socket Head Cap Screw	M8x16	2
79	CS275-79	Locking Knob	M8x20	1
80	CS275-80	Length Setting Rod Bracket		1
81	CS275-81	Upper Length Setting Rod		1
82	CS275-82	Lower Length Setting Rod		1
83	TS-1540081	Hex Nut	M12	1
84	CS275-84	Locking Knob	M8x18	1
85	CS275-85	Filter		1
86	TS-1491031	Hex Cap Screw	M10x25	1
86-1	TS-1540071	Hex Nut	M10	1
87	CS275-87	Drain Cover		1
88	TS-0680031	Flat Washer	5/16"	2
89	TS-1504051	Socket Head Cap Screw	M8x25	2
90	TS-1504071	Socket Head Cap Screw	M8x35	1
91	CS275-91G	Support		1
92	TS-0680031	Flat Washer	5/16"	2
93	TS-1504041	Socket Head Cap Screw	M8x20	2
94	TS-1533032	Pan Head Machine Screw	M5x10	4
95	CS275-95	Stop Push Button		1
96	CS275-96	Start Push Button		1
97	CS275-97	Emergency Stop		1
98	CS275-98	2/4P Selection Switch	(3ph only)	1
99	CS275-99	Pump Selection Switch		1
100	CS275-100	Control Box Panel	(3ph)	1
	CS275-100-1	Control Box Panel	(1ph)	1
101	TS-0680031	Flat Washer	5/16"	2
102	TS-1490021	Hex Cap Screw	M8x16	2
103	CS275-103G	Electrical Control Box		1
104	CS275-104	Control Box Bottom Plate		1
105	CS275-105	Magnetic Contactor	12D (3ph)	1
	CS275-105-1	Magnetic Contactor	18D (1ph)	1
106	CS275-106	Fuse Set	(3ph)	4
	CS275-106-1	Fuse Set	(1ph)	4
	CS275-106-2	Fuse (not shown)	10A (3ph)	3
	CS275-106-3	Fuse (not shown)	2A (3ph/1ph)	1
	CS275-106-4	Fuse (not shown)	20A (1ph)	3
107	CS275-107G	Cover Plate	(3ph)	1
	CS275-107-1G	Cover Plate	(1ph)	1
108	CS275-108	Transformer	(3ph)	1
	CS275-108-1	Transformer	(1ph)	1
109	CS275-109	Relay		1
110	CS275-110	Plate		1
111	CS275-111	Support Plate		1

Index No.	Part No.	Description	Size	Qty
112	TS-0680031	Flat Washer	5/16"	2
113	TS-1504031	Socket Head Cap Screw	M8x16	2
114	CS275-114	Screw	M5x6	2
119	CS275-119	Oil Seal	35x47x8	1
120	CS275-120	Rubber Gasket		1
121	CS275-121	Rubber Sheet		2
122	CS275-122	Holder Plate		1
123	CS275-123	Anti-Dust Plate		1
125	CS275-125	Stopper		2
126	CS275-126	Angle Scale		1

### 16.3.1 CS-275 and CS-315 Cold Saws (Stand Assembly) – Exploded View

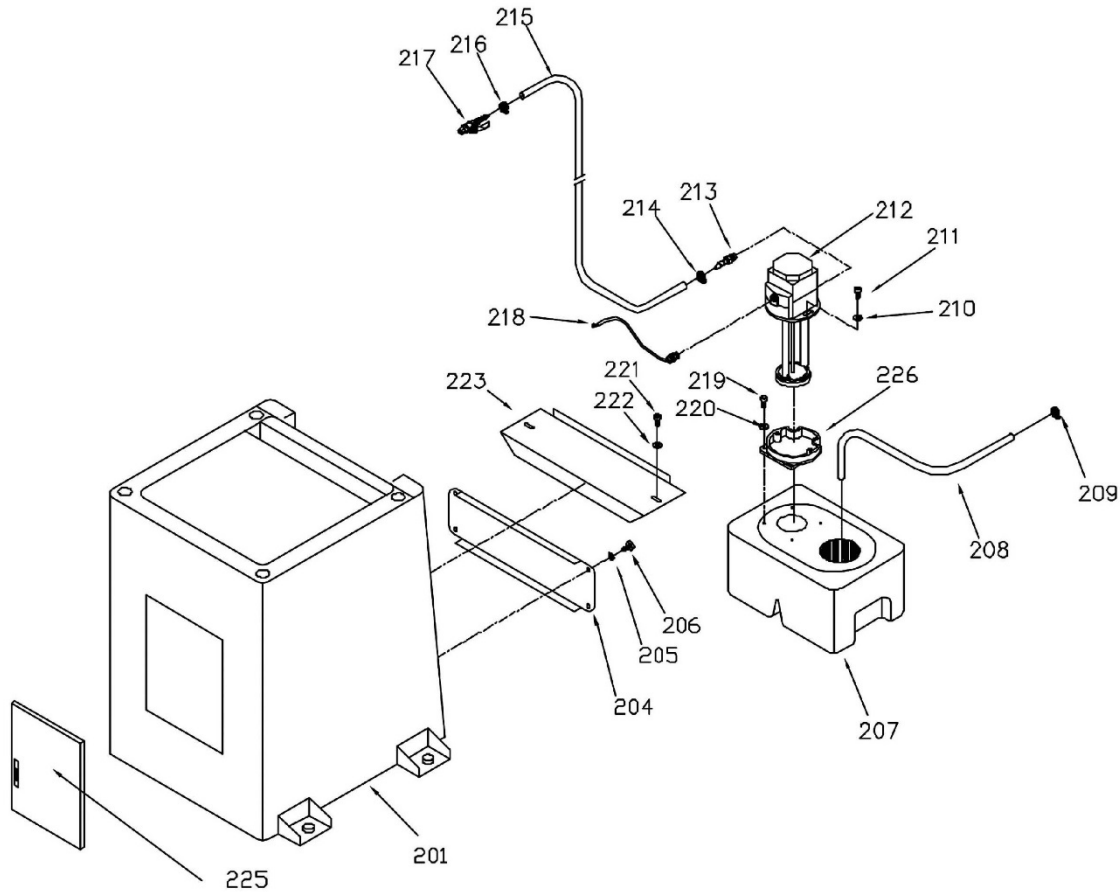

### 16.3.2 CS-275 and CS-315 Cold Saws (Stand Assembly) – Parts List

Index No.	Part No.	Description	Size	Qty
201	CS275-201G	Stand		1
204	CS275-204G	Support Plate		1
205	TS-0680031	Flat Washer	5/16"	4
206	TS-1490021	Hex Cap Screw	M8x16	4
207	CS275-207	Coolant Tank		1
208	CS275-208	Hose	1/2"	1
209	CS275-209	Hose Clamp	1"	1
210	TS-1550021	Flat Washer	M4	2
211	CS275-211	Socket Head Cap Screw	M4x18	2
212	CS275-212	Coolant Pump	230V, 1Ph	1
	CS275-212-1	Coolant Pump	115/230V, 1Ph	1
213	CS275-213	Connecting Bolt		1
214	CS275-214	Hose Clamp		1
215	CS275-215	Hose	5/16"	1
216	CS275-216	Hose Clamp	1/4"	1
217	CS275-217	Valve		1
218	CS275-218	Wire		1
219	TS-0050011	Hex Cap Screw	1/4"-20x1/2"	4
220	TS-0680021	Flat Washer	1/4"	4
221	TS-1490021	Hex Cap Screw	M8x16	2
222	TS-0680031	Flat Washer	5/16"	2
223	CS275-223G	Support Plate		1
225	CS275-225G	Door and Latch		1
226	CS275-226	Collar		1



427 New Sanford Road  
LaVergne, TN 37086  
Phone: 800-274-6848  
[www.jettools.com](http://www.jettools.com)