

## ENGINE TOOL PARTS LIST

### ENGINE GRASS TRIMMER Model CG 22EAB

2010 4 1

(E1)

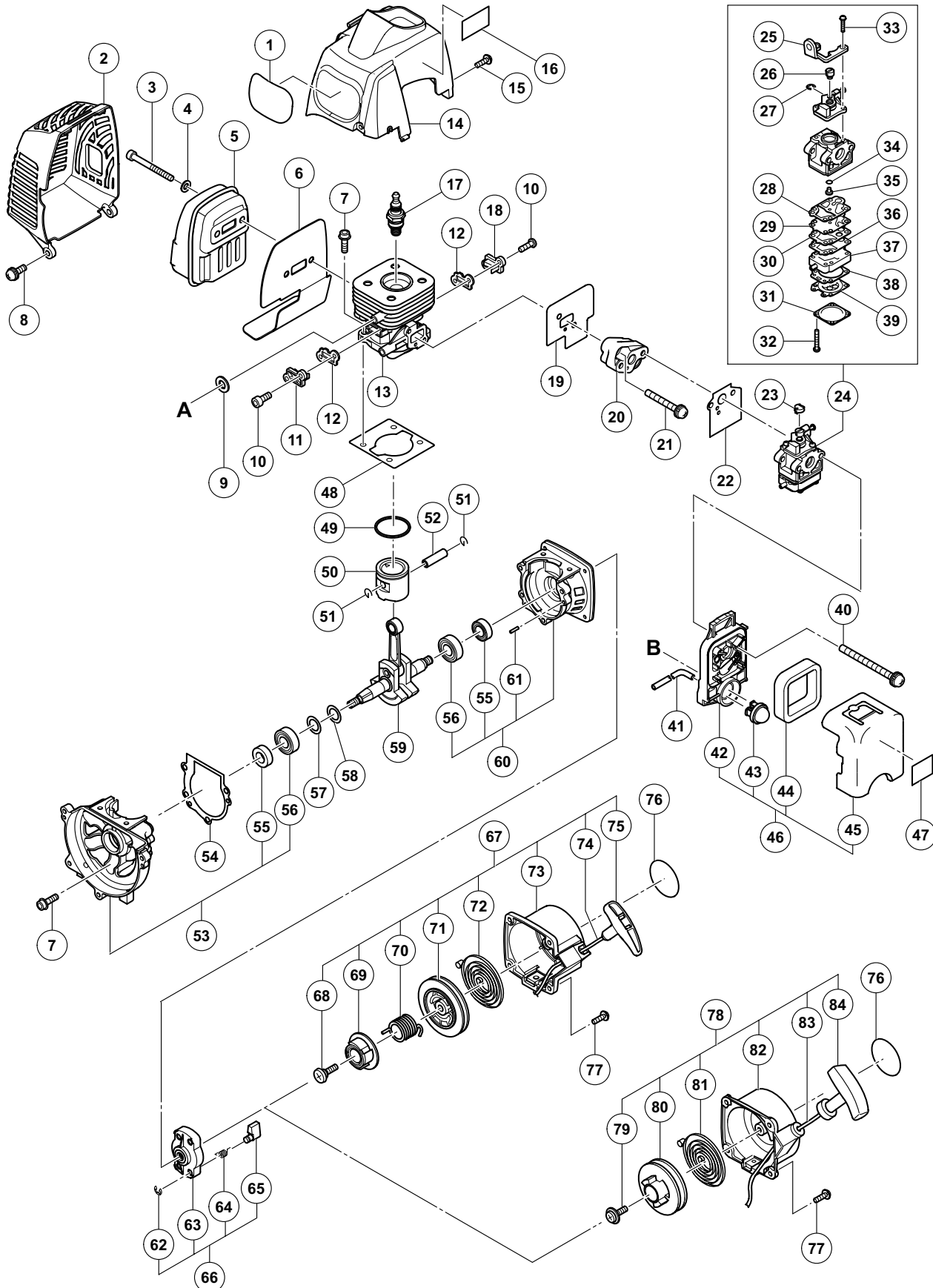

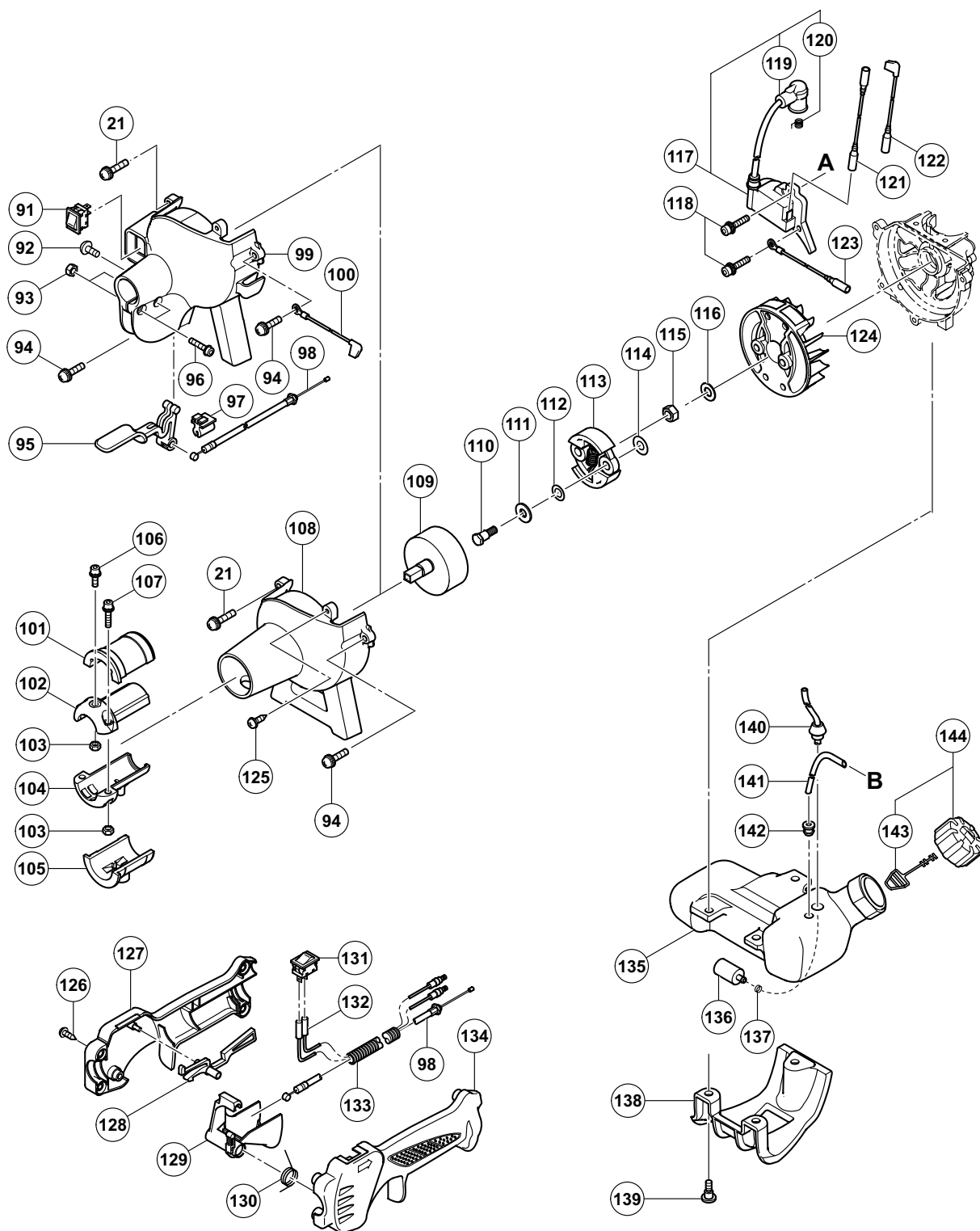

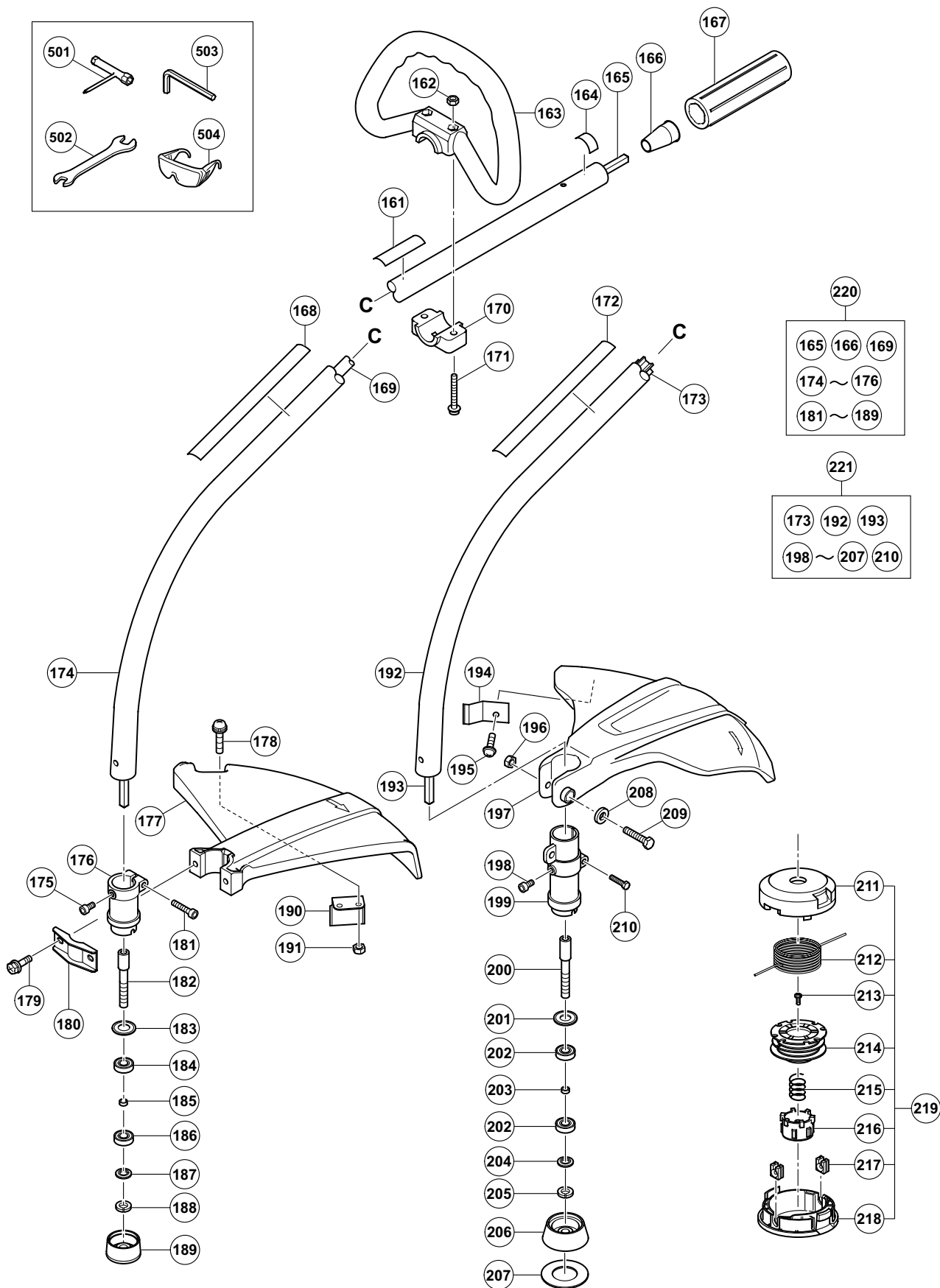

**PARTS**

CG 22EAB

ITEM NO.	CODE NO.	DESCRIPTION	NO. USED	REMARKS
		HITACHI LABEL	1	
*	2 669-6571	MUFFLER PROTECTOR	1	
*	2 669-6555	MUFFLER PROTECTOR	1	FOR EUROPE (LP), USA (SLP), CAN (SLP)
	3 668-4638	HEX. HOLE BOLT M6 X 55	2	
	4 949-432	BOLT WASHER M6 (10 PCS.)	2	
*	5 669-6570	MUFFLER	1	
*	5 669-6554	MUFFLER	1	FOR EUROPE (LP), USA (SLP), CAN (SLP)
	6 669-6553	HEAT PROTECTION PANEL	1	
	7 668-4586	HEX. HOLE BOLT M5 X 18/S	8	
	8 887-021	SCREW (W/WASHERS) M5 X 16 (BLACK)	2	
*	9 668-4600	WASHER	1	FOR EUROPE (LP), USA (SLP), CAN (SLP)
	10 668-4595	HEX. HOLE BOLT M4 X 12/S	4	
	11 669-6536	INTAKE COVER (B)	1	
	12 669-6534	COVER PACKING	2	
	13 669-6527	CYLINDER	1	
*	14 669-6528	CYLINDER COVER	1	
*	14 669-6529	CYLINDER COVER	1	FOR USA (SLP), CAN (SLP)
	15 307-606	MACHINE SCREW (W/WASHERS) M4 X 20 (BLACK)	2	
	16	CAUTION LABEL	1	
*	17 668-4584	SPARK PLUG BMR7A	1	
*	17 668-5052	SPARK PLUG CJ6	1	FOR USA (SLP), CAN (SLP), MEX (L), UAE (L), TPE (L), SIN (L)
	18 669-6535	INTAKE COVER (A)	1	
	19 669-6548	INTAKE PACKING	1	
	20 669-6943	CARBURETOR INSULATOR	1	
	21 880-734	MACHINE SCREW (W/WASHERS) M5 X 25 (BLACK)	3	
	22 668-4616	CARBURETOR GASKET	1	
	23 668-4628	SWIVEL CAP	1	
	24 669-6550	CARBURETOR ASS'Y WYC-22	1	INCLUD. 25-39
	25	BRACKET CABLE	1	
	26	SWIVEL	1	
	27 668-4696	STOP RING	1	
	28 668-4692	PUMP GASKET	1	
	29 668-4693	PUMP DIAPHRAGM	1	
	30 669-1242	PUMP PLATE	1	
	31 668-5222	DIAPHRAGM COVER	1	
	32 669-1312	SET SCREW	4	
	33	SCREW	2	
	34 668-4695	O-RING	1	
	35	JET	1	
	36 669-1234	CIRCUIT PLATE	1	
	37	BODY PUMP	1	
	38 668-5220	DIAPHRAGM PACKING	1	
	39 668-4690	METERING DIAPHRAGM COMP.	1	
	40 307-224	MACHINE SCREW (W/WASHERS) M5 X 60 (BLACK)	2	
	41 669-6962	FUEL PIPE	1	
	42	AIR CLEANER HOUSING	1	
	43 668-5139	PRIMING PUMP COMP.	1	
	44 669-0347	CLEANER ELEMENT	1	
	45	CLEANER COVER	1	

**PARTS**

CG 22EAB

ITEM NO.	CODE NO.	DESCRIPTION	NO. USED	REMARKS
46	669-6549	AIR CLEANER ASS'Y	1	INCLUD. 42-45
* 47		START LABEL (A)	1	FOR USA (SLP), CAN (SLP)
48	669-6530	CYLINDER PACKING	1	
49	669-6532	PISTON RING	1	
50	669-6531	PISTON	1	
51	668-4590	PISTON PIN CIRCLIP	2	
52	669-6944	PISTON PIN	1	
53	669-6538	CRANK CASE (B) COMP	1	INCLUD. 55, 56
54	669-6539	CRANK CASE PACKING	1	
55	668-4607	OIL SEAL TB 12227	2	
56	668-4608	BALL BEARING 6001 C3	2	
57	669-6946	SHIM	1	
58	669-6945	SHIM	1	
59	669-6533	CRANK SHAFT COMP.	1	
60	669-6537	CRANK CASE (A) COMP	1	INCLUD. 55, 56, 61
61	669-5521	KNOCK PIN 4 X 12	2	
* 62		RETAINING RING (E-TYPE) D5	2	
* 62		RETAINING RING (E-TYPE) D5	2	FOR USA (SLP), CAN (SLP)
* 63		STARTER PULLEY	1	
* 63		STARTER PULLEY	1	FOR USA (SLP), CAN (SLP)
* 64		STARTER PAWL SPRING	2	
* 64		STARTER PAWL SPRING	2	FOR USA (SLP), CAN (SLP)
* 65		STARTER PAWL	2	
* 65		STARTER PAWL	2	FOR USA (SLP), CAN (SLP)
* 66	669-6471	STARTER PULLEY ASS'Y	1	INCLUD. 62-65
* 66	668-4681	STARTER PULLEY ASS'Y	1	INCLUD. 62-65 FOR USA (SLP), CAN (SLP)
* 67	668-4672	RECOIL STARTER BODY ASS'Y	1	INCLUD. 68-75 FOR USA (SLP), CAN (SLP)
68	668-4679	SET SCREW	1	
69	668-4678	CAM PLATE	1	
70	668-4677	DUMPER SPRING	1	
71	668-4676	STARTER ROPE REEL	1	
72	668-4675	RECOIL SPRING	1	
73	668-4673	RECOIL STARTER BODY COMP.	1	
74	668-4674	STARTER ROPE 3.5 X 860	1	
75	668-4680	STARTER HANDLE	1	
76		NAME PLATE	1	
77	993-539	MACHINE SCREW (W/WASHERS) M4 X 16	2	
* 78	669-6572	RECOIL STARTER BODY ASS'Y	1	INCLUD. 79-84 EXCEPT FOR USA (SLP), CAN (SLP)
79	669-3633	SET SCREW	1	
80		REEL	1	
81	668-4675	RECOIL SPRING	1	
82		STARTER CASE	1	
83	669-3168	STARTER ROPE	1	
84	669-3227	STARTER HANDLE	1	
* 91	669-6565	STOP SWITCH	1	FOR MEX (L), UAE (L), TPE (L), SIN (L)
* 92	331-683	TAPPING SCREW D4 X 10	1	FOR MEX (L), UAE (L), TPE (L), SIN (L)
* 93	302-012	NUT M5 (BLACK)	2	FOR MEX (L), UAE (L), TPE (L), SIN (L)
94	995-096	MACHINE SCREW (W/WASHERS) M5 X 20 (BLACK)	2	
* 95	669-6563	THROTTLE LEVER	1	FOR MEX (L), UAE (L), TPE (L), SIN (L)

**PARTS**

CG 22EAB

ITEM NO.	CODE NO.	DESCRIPTION	NO. USED	REMARKS	
* 96	305-583	HEX. SOCKET HD. BOLT (W/SP. WASHER) M5 X 20	2	FOR MEX (L), UAE (L), TPE (L), SIN (L)	
* 97	669-6568	WIRE HOLDER	1	FOR MEX (L), UAE (L), TPE (L), SIN (L)	
* 98	669-6560	THROTTLE WIRE COMP	1		
* 98	669-6564	THROTTLE WIRE COMP.	1	FOR MEX (L), UAE (L), TPE (L), SIN (L)	
* 99	669-6562	FAN CASE COMP (BENT)	1	FOR MEX (L), UAE (L), TPE (L), SIN (L)	
* 100	669-6567	EARTH CORD	1	FOR MEX (L), UAE (L), TPE (L), SIN (L)	
	101	669-6963	ANTI VIBE RUBBER (A)	1	
	102	669-6542	PIPE HOLDER (A)	1	
	103	302-012	NUT M5 (BLACK)	3	
	104	669-6543	PIPE HOLDER (B)	1	
	105	669-6964	ANTI VIBE RUBBER (B)	1	
	106	668-4667	HEX. HOLE BOLT M5 X 12/S	1	
	107	305-583	HEX. SOCKET HD. BOLT (W/SP. WASHER) M5 X 20	2	
	108	669-6540	FAN CASE COMP	1	
	109	669-6561	CLUTCH SHAFT COMP	1	
	110	669-6469	STEP BOLT	2	
	111	668-4648	BENT WASHER 8	2	
	112	669-6546	CLUTCH PLATE (A)	2	
	113	669-6948	CLUTCH	1	
	114	669-6547	CLUTCH WASHER (B)	2	
	115	668-5337	FLYWHEEL NUT	1	
	116	323-212	BOLT WASHER M8 (BLACK)	1	
	117	669-6929	IGNITION COIL ASS'Y	1	INCLUD. 119, 120
	118	668-4599	HEX. HOLE BOLT M4 X 18/WS	2	
	119		PLUG CAP	1	
	120		METAL FITTING OF PLUG CAP	1	
	121	669-6544	CORD	1	
* 122	669-6566	CORD	1	FOR MEX (L), UAE (L), TPE (L), SIN (L)	
	123	669-6545	EARTH CORD	1	
	124	669-6928	MAGNETO ROTOR COMP.	1	
	125	668-4636	TAPPING SCREW D4.5 X 16	1	
	126	305-812	TAPPING SCREW (W/FLANGE) D4 X 16 (BLACK)	4	
* 127	669-6487	HANDLE (B)	1	FOR EUROPE (LP), RUS (LP), CHN (L)	
* 127	669-6942	HANDLE (B)	1	FOR USA (SLP), CAN (SLP)	
* 128	669-6490	LOCK LEVER	1	FOR EUROPE (LP), RUS (LP), CHN (L)	
	129	669-6488	LEVER	1	
	130	669-6489	SPRING (A)	1	
	131	669-6940	STOP SWITCH	1	
	132	669-6491	STOP SWITCH CORD	2	
	133	669-6967	PROTECTION TUBE	1	
* 134	669-6486	HANDLE (A)	1	FOR EUROPE (LP), RUS (LP), CHN (L)	
* 134	669-6941	HANDLE (A)	1	FOR USA (SLP), CAN (SLP)	
* 135	669-6569	TANK	1		
* 135	669-6552	TANK	1	FOR USA (SLP), CAN (SLP)	
	136	668-4620	PUMP FILTER BODY COMP.	1	
	137	669-6949	CLIP	1	
* 138	669-6556	STAND	1	FOR EUROPE (LP), RUS (LP), USA (SLP), CAN (SLP), CHN (L)	
* 139	669-6557	FLANGE BOLT	3		
* 139	669-6574	BOLT (W/FLANGE)	3	FOR MEX (L), UAE (L), TPE (L), SIN (L)	

**PARTS**

CG 22EAB

ITEM NO.	CODE NO.	DESCRIPTION	NO. USED	REMARKS
140	669-6551	SHIELD TUBE	1	
141	669-6476	FUEL PIPE (PINK)	1	
142	669-6970	RETURN GROMMET	1	
143	668-4625	TANK CAP CHAIN	1	
* 144	668-4622	TANK CAP ASS'Y	1	INCLUD. 143
* 144	668-5071	TANK CAP ASS'Y	1	INCLUD. 143 FOR MEX (L), UAE (L), TPE (L), SIN (L)
161	668-4852	LEVEL MARK	1	
162	949-556	NUT M6 (10 PCS.)	2	
163	669-6975	LOOP HANDLE	1	
164	668-4851	LEVEL MARK	1	
165	669-8325	FLEXIBLE SHAFT	1	
166	669-8324	SPACER (E)	1	
* 167	669-6581	GRIP	1	FOR MEX (L), UAE (L), TPE (L), SIN (L)
168	668-4850	CAUTION MARK 9900RPM	1	
169	669-8323	FLEXIBLE LINER	1	
170	669-6972	HANDLE HOLDER (A)	1	
171	669-6974	BOLT (BLACK) M6	2	
* 172		CAUTION MARK USA	1	
173	669-8337	FLEXIBLE LINER (A)	1	
* 174	669-8322	MAIN PIPE	1	FOR EUROPE (LP), RUS (LP), CHN (L)
* 174	669-8321	MAIN PIPE	1	FOR MEX (L), UAE (L), TPE (L), SIN (L)
175	949-819	HEX. SOCKET HD. BOLT M5 X 10 (10 PCS.)	1	
176	669-8326	CUTTER CASE	1	
177	669-8332	SAFETY COVER	1	
178	990-541	MACHINE SCREW (W/WASHERS) M5 X 16	2	
179	669-8334	BOLT M6	2	
180	669-8335	SAFETY COVER BRACKET	1	
181	949-662	HEX. SOCKET HD. BOLT M5 X 25 (10 PCS.)	1	
182	669-8327	CUTTER SHAFT	1	
183	669-8331	BEARING WASHER	1	
184	608-VVM	BALL BEARING 608VVC2PS2L	1	
185	669-8328	COLLAR	1	
186	608-DDM	BALL BEARING 608DDC2PS2L	1	
187	669-8329	WASHER T1.6	1	
188	949-457	SPRING WASHER M8 (10 PCS.)	1	
189	669-8330	CUTTER HOLDER	1	
190	669-8333	KNIFE	1	
191	949-555	NUT M5 (10 PCS.)	2	
192	669-8336	MAIN PIPE (A)	1	
193	668-5038	FLEXIBLE SHAFT (A)	1	
194	668-5015	KNIFE	1	
195	668-5074	TAPPING SCREW D5 X 16	1	
196	668-4792	NUT M6	1	
197	669-8341	SAFETY COVER	1	
198	949-707	BOLT M5 X 10 (10 PCS.)	1	
199	669-8338	CUTTER CASE (A)	1	
200	669-8339	CUTTER SHAFT (A)	1	
201	669-8340	BEARING WASHER (A)	1	
202	608-DDM	BALL BEARING 608DDC2PS2L	2	

**PARTS**

CG 22EAB

ITEM NO.	CODE NO.	DESCRIPTION	NO. USED	REMARKS
203	668-5014	COLLAR (A)	1	
204	668-5016	WASHER (A)	1	
205	949-457	SPRING WASHER M8 (10 PCS.)	1	
206	668-5073	CUTTER HOLDER (A)	1	
207	668-5001	WASHER	1	
208	668-4639	WASHER 6	1	
209	668-4995	PLUS BOLT M6 X 45	1	
210		HEX. SOCKET HD. BOLT (W/SP. WASHER) M5	1	
211		COVER	1	
212		NYLON CORD	1	
213		SET SCREW	1	
214		REEL	1	
215		RETURN SPRING SET SCREW	1	
216		BUTTON	1	
217		CORD GUIDE	2	
218		CASE	1	
219	669-6597	NYLON HEAD (R)	1	INCLUD. 211-218
220	669-6580	MAIN PIPE ASS'Y	1	INCLUD. 165, 166, 174-176, 181-189
* 221	669-6582	MAIN PIPE (A) ASS'Y	1	INCLUD. 192, 193, 198-207, 210 FOR USA (SLP), CAN (SLP)

**STANDARD ACCESSORIES**

ITEM NO.	CODE NO.	DESCRIPTION	NO. USED	
501	668-4764	BOX WRENCH (HEX. SOCKRT 17/19)	1	
502	669-6596	WRENCH 8 X 10	1	
503	944-458	HEX. BAR WRENCH 4MM	1	
504	875-769	SAFETY GLASSES	1	