

CUTTING SAW

C-356-II

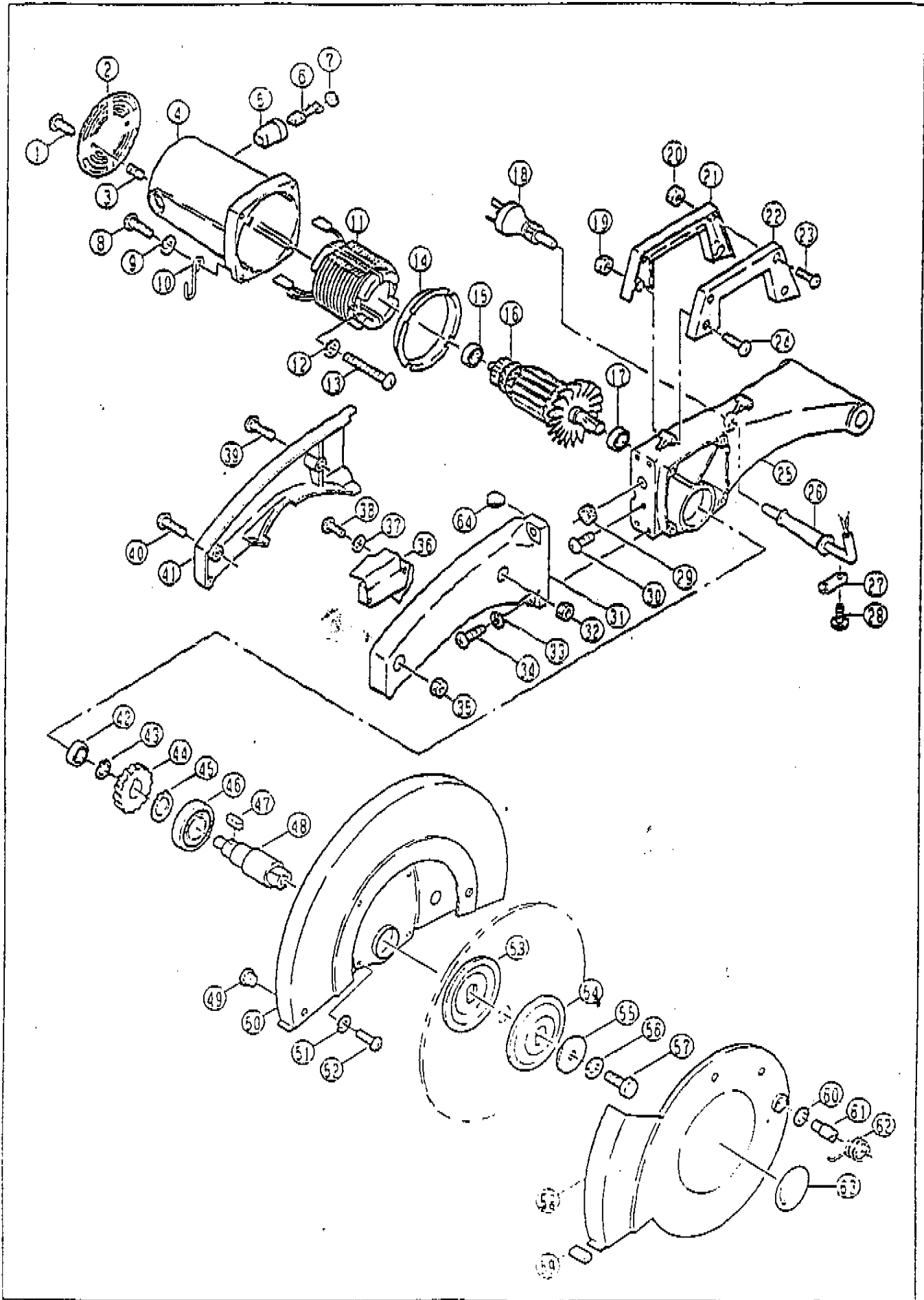

CUTTING SAW

C-356-II

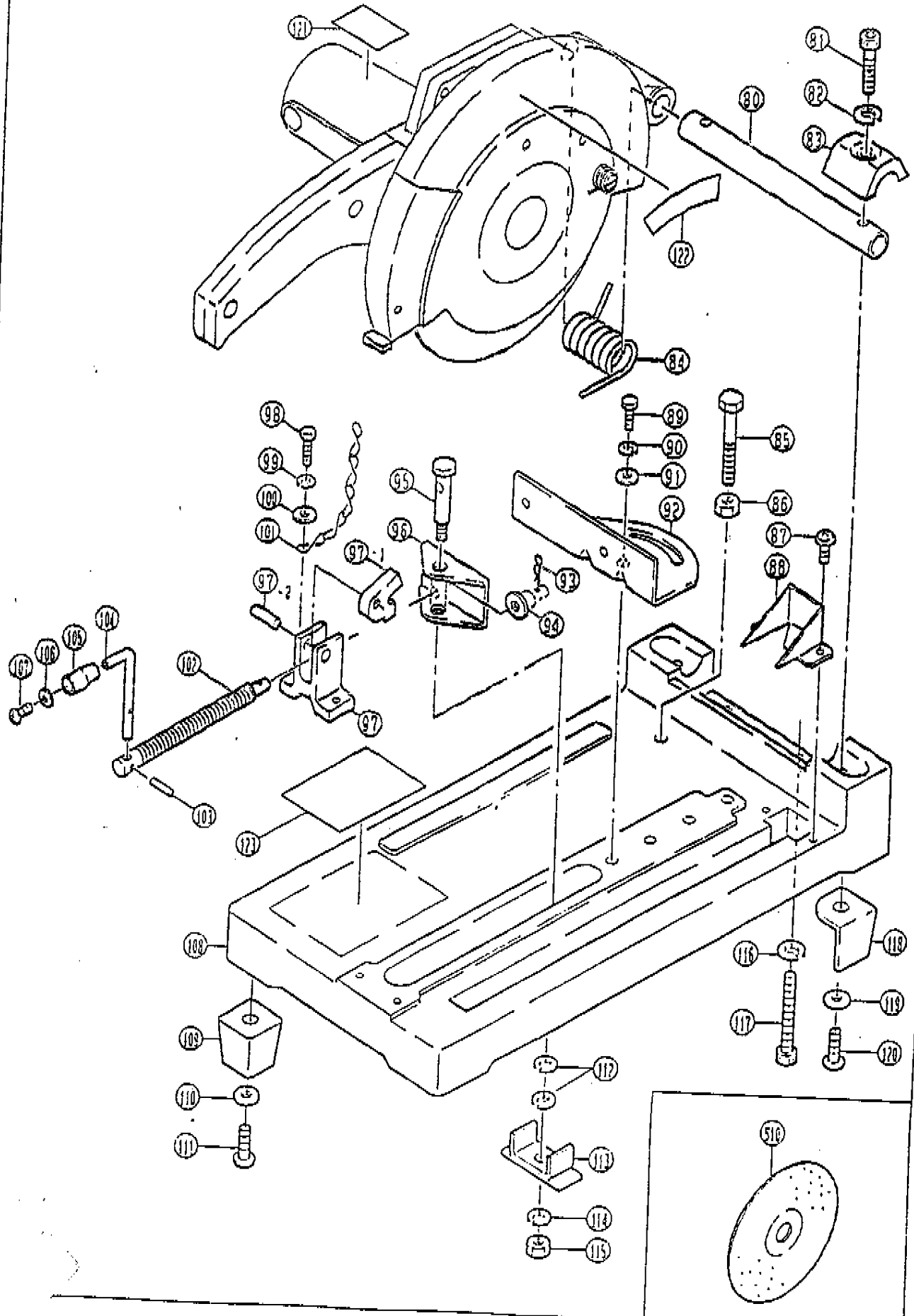

MODEL C-356-II

REF	PART NO.	DESCRIPTION	QTY	REF	PART NO.	DESCRIPTION	QTY
1	9000512	PHILLIPS PAN SCREW M5X12	2	50	1880054	SAFETY COVER	1
2	1880053	REAR COVER	1	51	9550500	SPRING WASHER M5	4
3	9280506	CLAMP SCREW M5X6	2	52	9000512	PHILLIPS PAN SCREW M5X12	4
4	1800040	MOTOR HOUSING	1	53	1940012	FLANGE	1
5	1570004	BRUSH HOLDER	2	54	1940012	FLANGE	1
6	1540040	CARBON BRUSH	2	55	1900103	FLAT WASHER	1
7	1570005	BRUSH HOLDER CAP	4	56	9551000	SPRING WASHER M10	1
8	9000525	PHILLIPS PAN SCREW M5X25	4	57	1130234	HEX. HEAD SCREW	1
9	9550500	SPRING WASHER M5	4	58	1880055	SAFETY COVER	1
10	1290010	CHAIN HOOK	1	59	1900106	WASHER	1
11	1500005	FIELD COIL 115V	1	60	1900107	WASHER	1
12	9550500	SPRING WASHER M5	2	61	1100054	SPINDLE	1
13	9000568	PHILLIPS PAN SCREW M5X68	2	62	1180051	TORSION SPRING	1
14	1490007	FAN GUIDE	1	63	1920084	LABEL	1
15	9826200	BALL BEARING #6200ZZ	1	64	1370023	RUBBER PLUG	1
16	1460005	ARMATURE 115V	1	80	1100051	HINGE CORE	1
17	9826202	BALL BEARING #6202ZZ	1	81	9220840	HEX. SOCKET HEAD BOLT M8X40	2
18	1520025	CORD ASS'Y	1	82	9550800	SPRING WASHER M8	2
19	9300400	HEX NUT M4	2	83	1150097	HINGE CORE COVER	1
20	9300500	HEX NUT M5	2	84	1180050	TORSION SPRING	1
21	1830039	HANDLE	1	85	1130236	ADJUSTED BOLT	1
22	1830038	HANDLE	1	86	1130237	NUT	1
23	9000530	PHILLIPS PAN SCREW M5X30	2	87	1130238	SCREW 3/8"X1/4"	2
24	9000428	PHILLIPS PAN SCREW M4X28	2	88	1150094	CHIP PROTECTOR	1
25	1800039	UPPER ARM	1	89	9221040	HEX SOCKET HEAD BOLT M10X40	2
26	1560016	CORD HOLDER	1	90	9551000	SPRING WASHER M10	2
27	1560017	CORD CLAMP	1	91	1900130	WASHER	2
28	1130235	(+) SCREW	2	92	1150095	GUIDE PLATE	1
29	1560015	BUSHING	1	93	1120042	PIN	1
30	9000512	PHILLIPS PAN SCREW M5X12	1	94	1900101	WASHER	1
31	1830040	HANDLE	1	95	1130233	SCREW STUD	1
32	9300500	HEX NUT M5	1	96	1150096	WISE PLATE	1
33	9550500	SPRING WASHER M5	4	97	1080055	WISE	1
34	9000520	PHILLIPS PAN SCREW M5X20	4	98	9190825	HEX. HEAD BOLT M8X25	2
35	9300500	HEX NUT M5	1	99	9550800	SPRING WASHER M8	2
36	1550033	SWITCH	1	100	9570800	WASHER 8X17X1.6	2
37	9550400	SPRING WASHER M4	2	101	1290009	CHAIN	1
38	9000408	PHILLIPS PAN SCREW M4X8	2	102	1130232	SCREW ROD	1
39	9000525	PHILLIPS PAN SCREW M5X25	1	103	1120043	PIN 3/20"X3/4"	1
40	9000530	PHILLIPS PAN SCREW M5X30	1	104	1100050	PIVOT ROD	1
41	1830041	HANDLE	1	105	1100049	HANDLE SHAFT	1
42	9826000	BALL BEARING #6000ZZ	1	106	1900104	WASHER	1
43	9522000	RETAINING RING R-20	1	107	9000410	PHILLIPS PAN SCREW M4X10	1
44	1200020	GEAR	1	108	1850025	BASE	1
45	9522500	RETAINING RING R-25	1	109	1370021	RUBBER FOOT	3
46	9826305	BALL BEARING #6305ZZ	1	110	1900101	WASHER	3
47	1100055	KEY 4X4X10	1	111	9000825	PHILLIPS PAN SCREW M8X25	3
48	1100052	SPINDLE	1	112	9551000	SPRING WASHER M10	2
49	1370022	RUBBER WASHER	1	113	1290008	WISE GUIDE	1

REF	PART NO.	DESCRIPTION	QTY	REF	PART NO.	DESCRIPTION	QTY
114	9551000	SPRING WASHER M10	1				
115	9301000	HEX NUT M10	1				
116	9570800	WASHER 3X17X1.6	2				
117	1130239	BOLT M8X30	2				
118	1150093	IRON FOOT	1				
119	1900101	WASHER	1				
120	9000815	PHILLIPS PAN SCREW M9X15	1				
121	1920085	LABEL	1				
122	1920086	LABEL	1				
123	1920087	WARNING LABEL	1				
	190082	MANUAL					
STANDARD ACCESSORIES							
1510		ABRASIVE WHEEL					
	1100057	lock pin					
	1240190	wrench					
		SEE CATALOG FOR ASSORTMENT					

SERVICE NOTES:

