

RYOBI 9 in. BAND SAW - MODEL NUMBER BS904

FIGURE A

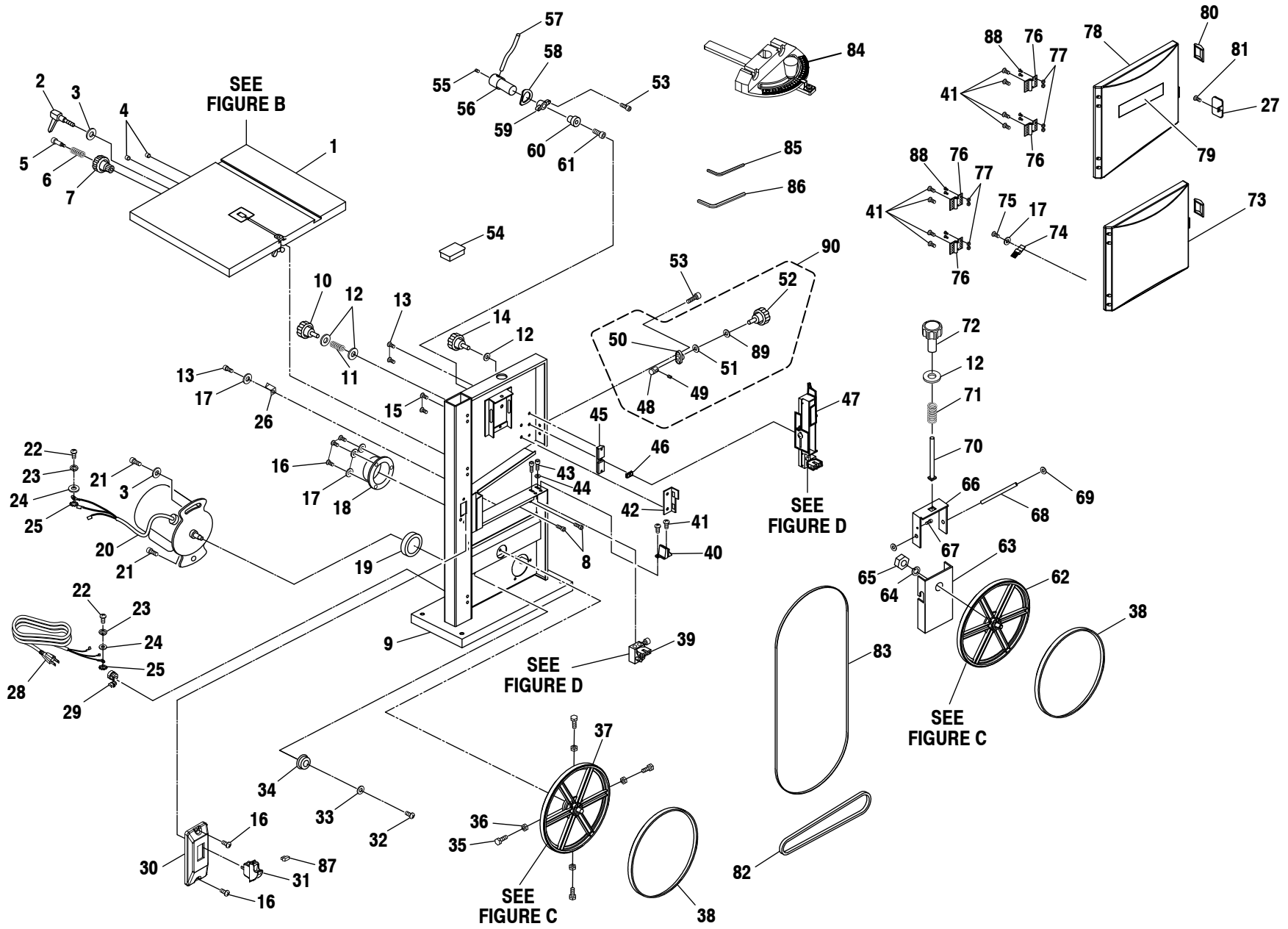

RYOBI 9 in. BAND SAW – MODEL NUMBER BS904

The model number will be found on a label attached to the motor housing. Always mention the model number in all correspondence regarding your **BAND SAW** or when ordering repair parts.

PARTS LIST FOR FIGURE A

KEY NO.	PART NUMBER	DESCRIPTION	QTY.	KEY NO.	PART NUMBER	DESCRIPTION	QTY.
1	089120406707	Table Assembly	1	26	089120406128	Indicator	1
2	089120406014	Lock Screw (M8 x 25 mm)	1	27	089120406110	Tracking View Window	1
3	089120406015	Washer (ID8.4 x OD24 x 2t)	2	28	089120406102	Power Cord	1
4	089120406018	Bushing	2	29	089120406103	Cord Clamp.....	2
5	089120406019	Rotate Bolt.....	1	30	089120406104	Switch Box.....	1
6	089120406020	Compression Spring	1	31	089120406711	Switch (Inc. Key No. 87).....	1
7	089120406021	Handle.....	1	32	089120406101	Screw (M5 x 10 mm)	1
8	089120406016	Screw (M6 x 14 mm, Hex Soc. Hd.)	2	33	089120406100	Washer (ID5.3 x OD15 x 1.2t)	1
9	089120406081	Frame.....	1	34	089120406099	Pulley.....	1
10	089120406032	Handle.....	1	35	089120406088	Screw (M6 x 16 mm, Hex Hd.).....	4
11	089120406033	Compression Spring	1	36	089120406089	Hex Nut (M6).....	4
12	089120406034	Washer (M8).....	4	37	089120406706	Lower Wheel Assembly.....	1
13	089120406035	Screw (M5 x 12 mm, Pan Hd.).....	2	38	089120406067	Tire	2
14	089120406036	Handle.....	1	39	089120406704	Lower Blade Guide Assembly.....	1
15	089120406058	Screw (M5 x 8 mm, Pan Hd.).....	2	40	089120406130	Blade Safe Cover	1
16	089120406078	Screw (M5 x 10 mm, Pan Hd.).....	5	41	089120406117	Screw (M4 x 8 mm)	10
17	089120406048	Washer (M5)	5	42	089120406129	Restrainer.....	1
18	089120406080	Dust Exhaust Port.....	1	43	089120406055	Screw (M6 x 8 mm, Hex Soc. Hd.)	2
19	089120406087	Filter	1	44	089120406002	Washer (ID6.3 x OD16 x 1.5t).....	1
20	089120406702	Motor.....	1	45	089120406038	Slide Plate	1
21	089120406086	Screw (M8 x 20 mm, Hex Soc. Hd.)	2	46	089120406039	Square Nut.....	1
22	089120406082	Screw (M5 x 7 mm, Pan Hd.).....	2	47	089120406703	Upper Blade Guide Assembly.....	1
23	089120406084	Spring Washer (M5.3).....	2	48	089120406118	Gear	1
24	089120406085	Washer (M5).....	2	49	089120406119	Set Screw (M4 x 4 mm).....	1
25	089120406083	External Tooth Washer	2	50	089120406120	Handle Seat	1

WARNING: Improper repair of a double insulated tool can result in damage to the double insulation system possibly causing electrical shock or electrocution. Any repairs requiring disassembly of your tool requires safety testing and should only be performed by a Ryobi Authorized Service Center. For the service center nearest you call 1-800-525-2579.

RYOBI 9 in. BAND SAW – MODEL NUMBER BS904

The model number will be found on a label attached to the motor housing. Always mention the model number in all correspondence regarding your **BAND SAW** or when ordering repair parts.

PARTS LIST FOR FIGURE A CONTINUED

KEY NO.	PART NUMBER	DESCRIPTION	QTY.	KEY NO.	PART NUMBER	DESCRIPTION	QTY.
51	089120406121	Wavy Washer (M6)	1	77	089120406116	Hex Nut (M4)	8
52	089120406122	Handle.....	1	78	089120406107	Frame Cover (Upper).....	1
53	089120406031	Screw (M5 x 10 mm, Hex Soc. Hd.)	4	79	089120406902	Logo Label	1
54	089120406123	Square Cover	1	80	089120406108	Door Lock	2
55	089120406024	Set Screw (M5 x 6 mm).....	1	81	089120406109	Screw (M4.2 x 6 mm)	1
56	089120406025	Eccentric Shaft.....	1	82	089120406096	Belt (130 x 10)	1
57	089120406030	Blade Tensioner Lever.....	1	83	089120406124	Blade (62 in. x 6 mm x 0.3t)	1
58	089120406026	Washer (ID16 x OD21 x 0.3t)	1	84	089120406701	Miter Gauge Assembly.....	1
59	089120406027	Sleeve	1	85	089120406131	Hex Wrench (M2).....	1
60	089120406028	Eccentric	1	86	089120406132	Hex Wrench (M4).....	1
61	089120406029	Screw (M6 x 16 mm, Hex Soc. Hd.).....	1	87	089120406106	Switch Key	1
62	089120406705	Upper Wheel Assembly.....	1	88	089120406134	Screw (M4 x 10 mm).....	8
63	089120406062	Bracket.....	1	89	089120406133	Washer (ID6 x OD12 x 0.5t).....	1
64	089120406061	Spring Washer (M10).....	1	90	089120406708	Guide Height Knob Assembly (Inc. Key Nos. 48-52, 54 and 59)	1
65	089120406060	Hex Nut (M10)	1	Not Shown:			
66	089120406072	Bracket.....	1	089120406901	Warning Label	1	
67	089120406073	Screw (M5 x 8 mm, Hex Soc. Hd.)	1	089120406903	No Hands Label	1	
68	089120406070	Pin (8 x 90)	1	089120406904	Data Label.....	1	
69	089120406071	Check Ring.....	2	089120406905	Blade Adjust Label.....	1	
70	089120406074	Bolt (M8 x 80 mm, Special).....	1	089120406906	Blade Order Label	1	
71	089120406075	Compression Spring	1	089120406907	Height Lock Label	1	
72	089120406077	Handle.....	1	990000198	Operator's Manual		
73	089120406113	Frame Cover (Lower).....	1	11-19-12	(Rev:01)		
74	089120406112	Blade Brush	1				
75	089120406111	Screw (M4.8 x 10 mm)	1				
76	089120406115	Hinge.....	4				

WARNING: Improper repair of a double insulated tool can result in damage to the double insulation system possibly causing electrical shock or electrocution. Any repairs requiring disassembly of your tool requires safety testing and should only be performed by a Ryobi Authorized Service Center. For the service center nearest you call 1-800-525-2579.

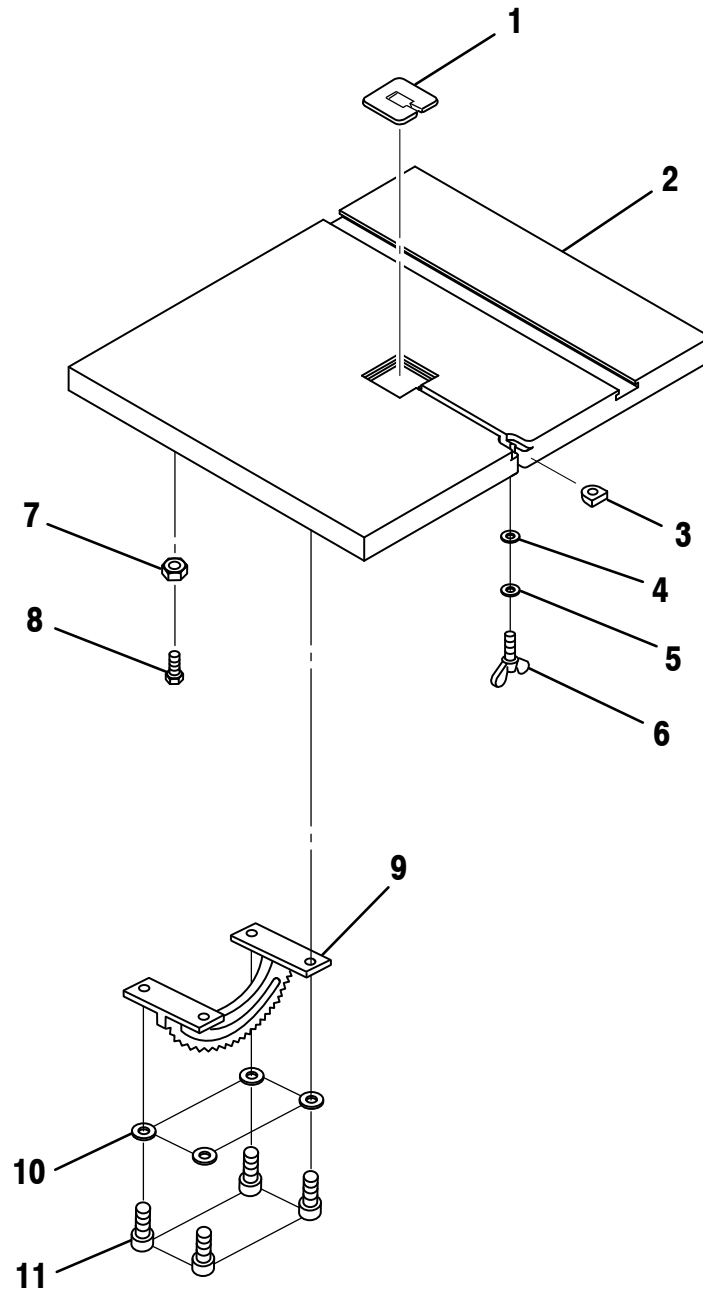

FIGURE B

RYOBI 9 in. BAND SAW – MODEL NUMBER BS904

The model number will be found on a label attached to the motor housing. Always mention the model number in all correspondence regarding your **BAND SAW** or when ordering repair parts.

PARTS LIST FOR FIGURE B

KEY NO.	PART NUMBER	DESCRIPTION	QTY.
1	089120406008	Table Insert.....	1
2	089120406009	Table.....	1
3	089120406010	D-Nut.....	1
4	089120406012	Washer (M6)	1
5	089120406011	Spring Washer (M6).....	1
6	089120406013	Wing Screw (M6).....	1
7	089120406089	Hex Nut (M6)	1
8	089120406125	Screw (M6 x 23 mm, Hex Hd.).....	1
9	089120406017	Saw Table Bracket (Trunnion).....	1
10	089120406022	Spring Washer (M8).....	4
11	089120406023	Screw (M8 x 14 mm, Hex Soc. Hd.)	4

WARNING: Improper repair of a double insulated tool can result in damage to the double insulation system possibly causing electrical shock or electrocution. Any repairs requiring disassembly of your tool requires safety testing and should only be performed by a Ryobi Authorized Service Center. For the service center nearest you call 1-800-525-2579.

UPPER WHEEL ASSEMBLY

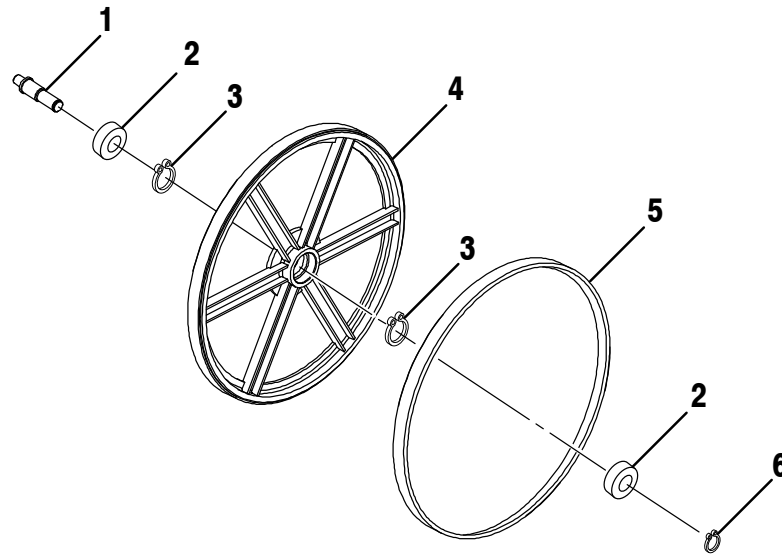

LOWER WHEEL ASSEMBLY

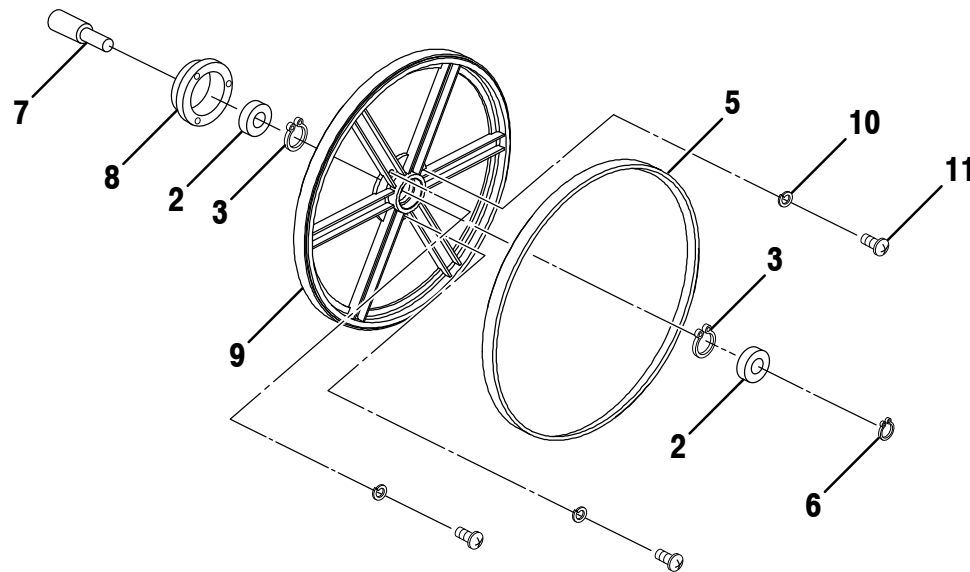

FIGURE C

RYOBI 9 in. BAND SAW – MODEL NUMBER BS904

The model number will be found on a label attached to the motor housing. Always mention the model number in all correspondence regarding your **BAND SAW** or when ordering repair parts.

PARTS LIST FOR FIGURE C

KEY NO.	PART NUMBER	DESCRIPTION	QTY.
1	089120406063	Shaft.....	1
2	089120406064	Ball Bearing (6000-2RZ).....	4
3	089120406065	Retaining Ring.....	4
4	089120406066	Blade Wheel (Upper).....	1
5	089120406067	Tire	2
6	089120406069	Retaining Ring.....	2
7	089120406090	Shaft.....	1
8	089120406091	Pulley.....	1
9	089120406093	Blade Wheel (Lower).....	1
10	089120406098	Spring Washer (M5).....	3
11	089120406097	Screw (M5 x 16 mm).....	3

WARNING: Improper repair of a double insulated tool can result in damage to the double insulation system possibly causing electrical shock or electrocution. Any repairs requiring disassembly of your tool requires safety testing and should only be performed by a Ryobi Authorized Service Center. For the service center nearest you call 1-800-525-2579.

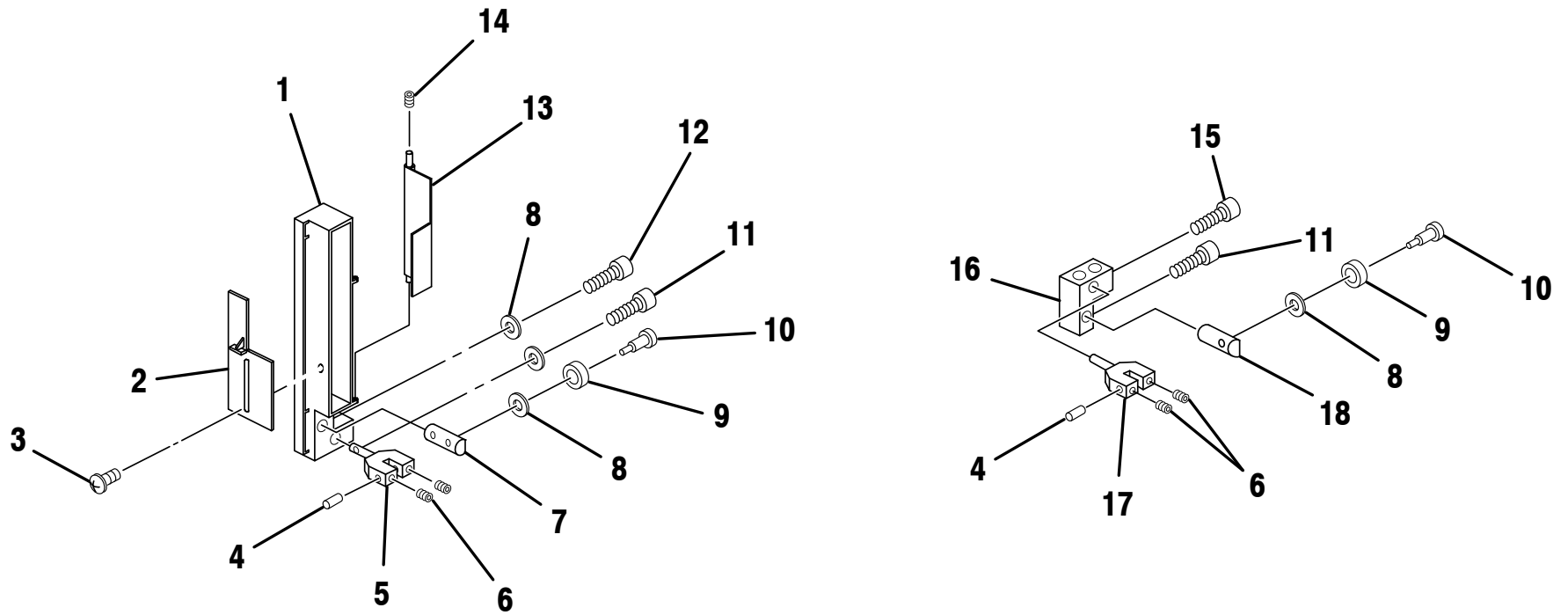

FIGURE D

RYOBI 9 in. BAND SAW – MODEL NUMBER BS904

The model number will be found on a label attached to the motor housing. Always mention the model number in all correspondence regarding your **BAND SAW** or when ordering repair parts.

PARTS LIST FOR FIGURE D

KEY NO.	PART NUMBER	DESCRIPTION	QTY.
1	089120406040	Guide Bar	1
2	089120406127	Sliding Blade Guard	1
3	089120406126	Screw (M4 x 10 mm)	1
4	089120406054	Pin (5 x 14)	4
5	089120406052	Guide Block (Upper).....	1
6	089120406051	Screw (M4 x 6 mm)	4
7	089120406049	Thrust Bearing Shaft (Upper)	1
8	089120406048	Washer (M5)	4
9	089120406047	Ball Bearing (606-2RZ).....	2
10	089120406046	Screw (Special)	2
11	089120406031	Screw (M5 x 10 mm, Hex Soc. Hd.)	2
12	089120406044	Screw (M5 x 16 mm, Hex Soc. Hd.)	1
13	089120406042	Blade Guard Shield	1
14	089120406041	Compression Spring	1
15	089120406045	Screw (M5 x 12 mm, Hex Soc. Hd.)	1
16	089120406057	Guide Block (Lower).....	1
17	089120406053	Guide Block (Lower).....	1
18	089120406050	Thrust Bearing Shaft (Lower)	1

WARNING: Improper repair of a double insulated tool can result in damage to the double insulation system possibly causing electrical shock or electrocution. Any repairs requiring disassembly of your tool requires safety testing and should only be performed by a Ryobi Authorized Service Center. For the service center nearest you call 1-800-525-2579.