

RYOBI 6 in. BENCH GRINDER – MODEL NUMBER BGH625

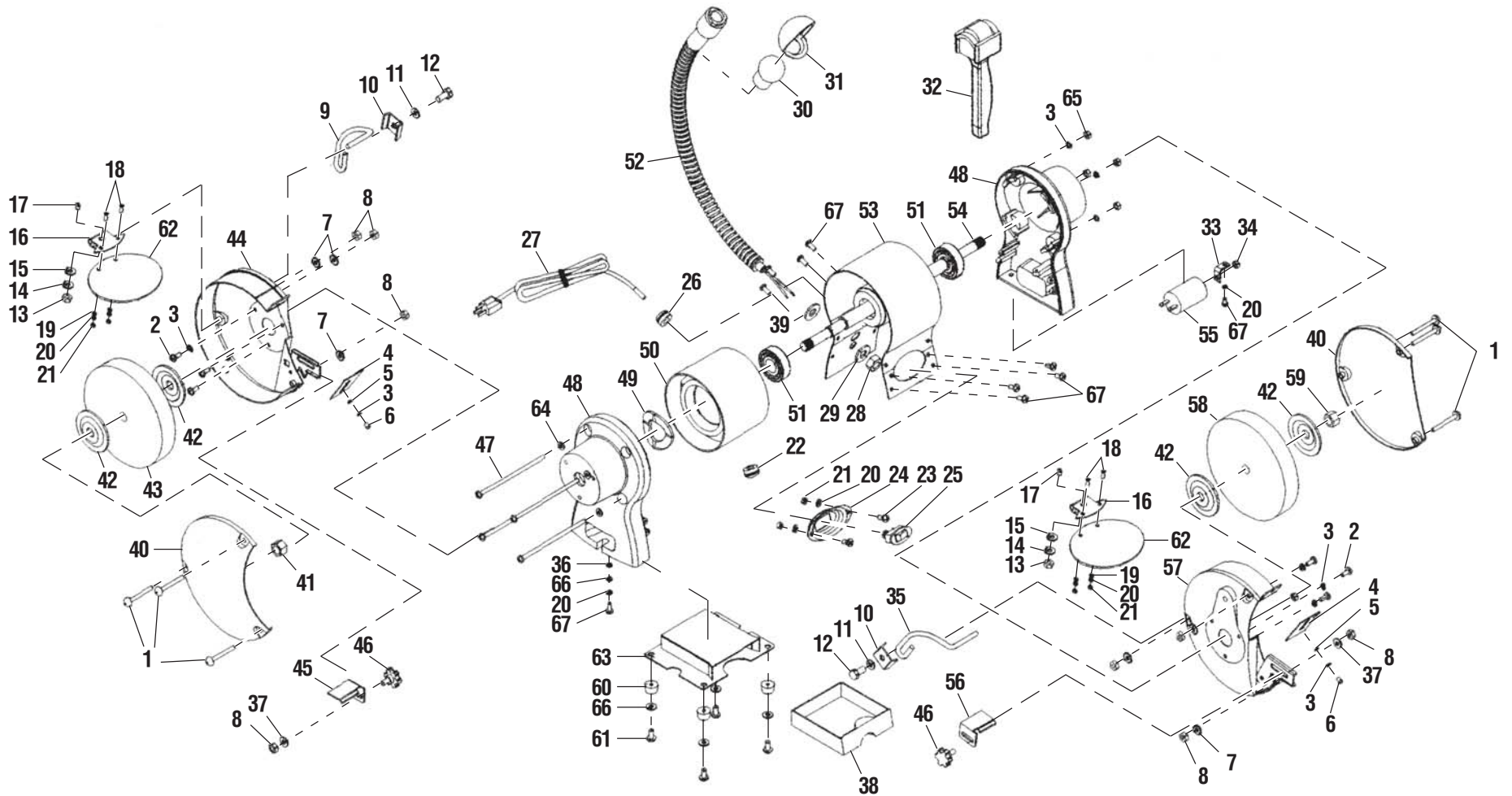

RYOBI 6 in. BENCH GRINDER – MODEL NUMBER BGH625

The model number will be found on a plate attached to the motor housing. Always mention the model number in all correspondence regarding your **Bench Grinder** or when ordering repair parts.

PARTS LIST

Key No.	Part Number	Description	Qty.	Key No.	Part Number	Description	Qty.
1	800104	* SCREW (M5 x 42 mm)	6	19	601610	* WASHER (4 mm)	4
2	600112	* SCREW (M5 x 10 mm)	6	20	601711	* LOCK WASHER (4 mm)	8
3	600212	* LOCK WASHER (5 mm)	12	21	601808	* HEX NUT (M4)	6
4	800702	SPARK DEFLECTOR	2	22	601901	CORD BUSHING	1
5	600306	* WASHER (5 mm)	2	23	602003	* SCREW (M4 x 8 mm)	2
6	604704	* SCREW (M5 x 8 mm)	2	24	801601	SWITCH PLATE	1
7	800806	* TOOTHED LOCK WASHER (5 mm)	6	25	602101	SWITCH	1
8	600506	* HEX NUT (M5)	8	26	602201	CORD CLIP	1
9	600601	LEFT EYESHIELD MOUNT ROD	1	27	602301	CORD W/PLUG	1
10	600702	EYESHIELD MOUNT ROD BRACKET	2	28	801701	* HEX NUT (M10 x 1 mm)	1
11	600806	* WASHER (8 mm)	2	29	801801	* LOCK WASHER (10 mm)	1
12	600902	* HEX BOLT (M8 x 14 mm)	2	30	802001	BULB (120V, 10W)	1
13	601002	* HEX NUT (M6)	2	31	606801	LAMP SHADE	1
14	601104	* LOCK WASHER (6 mm)	2	32	802201	WHEEL DRESSER	1
15	601204	* WASHER (6 mm)	2	33	802401	CAPACITOR SUPPORT	1
16	601302	EYESHIELD BRACKET	2	34	602401	* HEX NUT (M8)	1
17	601402	* CARRIAGE BOLT (M6 x 16 mm)	2	35	602501	RIGHT EYESHIELD MOUNT ROD	1
18	601504	* SCREW (M4 x 10 mm)	2	36	602601	* TOOTHED LOCK WASHER (4 mm)	1

WARNING: Improper repair of a double insulated tool can result in damage to the double insulation system possibly causing electrical shock or electrocution. Any repairs requiring disassembly of your tool requires safety testing and should only be performed by a Ryobi Authorized Service Center. For the service center nearest you call 1-800-525-2579.

* Standard Hardware Item – May Be Purchased Locally

RYOBI 6 in. BENCH GRINDER – MODEL NUMBER BGH625

The model number will be found on a plate attached to the motor housing. Always mention the model number in all correspondence regarding your **Bench Grinder** or when ordering repair parts.

PARTS LIST

Key No.	Part Number	Description	Qty.	Key No.	Part Number	Description	Qty.
37	602704	* BIG WASHER (5 mm)	2	55	603201	CAPACITOR	1
38	606201	COOLANT TRAY	1	56	607001	RIGHT WORKREST	1
39	803401	WASHER	1	57	607101	RIGHT WHEEL GUARD	1
40	606302	WHEEL COVER	2	58	606001	WHEEL (60#) 150 x 20 x 12.7 mm	1
41	602801	* HEX NUT LEFT SIDE (M12)	1	59	603301	* HEX NUT (M12)	1
42	602904	WHEEL FLANGE	4	60	607204	RUBBER FOOT	4
43	603601	WHEEL (36#) 150 x 20 x 12.7 mm	1	61	607304	* SCREW (M4 x 16 mm)	4
44	606401	LEFT WHEEL GUARD	1	62	603402	EYESHIELD	2
45	606501	LEFT WORKREST	1	63	607401	BOTTOM COVER	1
46	606602	KNOB	2	64	600306A	* WASHER (5 mm)	4
47	606604	* SCREW (M5 x 122 mm)	4	65	600506A	* HEX NUT (M5)	4
48	606702	END CAPS	2	66	601610A	* WASHER (4 mm)	5
49	603001	* WAVE WASHER (D35)	1	67	602003A	* SCREW (M4 x 8 mm)	10
50	604301	STATOR	1	68	607701	COOLANT TRAY STICKER (NOT SHOWN)	1
51	603101	BALL BEARING	2	69	607601A	DOME LABEL (NOT SHOWN)	1
52	801901	LAMP PIPE	1	70	607602A	WARNING LABEL (NOT SHOWN)	1
53	606901	METAL MOTOR HOUSING	1		972000880	OPERATOR'S MANUAL	
54	604401	ROTOR	1		972000880R	REPAIR SHEET (REV:00)	
					3-15-06		

WARNING: Improper repair of a double insulated tool can result in damage to the double insulation system possibly causing electrical shock or electrocution. Any repairs requiring disassembly of your tool requires safety testing and should only be performed by a Ryobi Authorized Service Center. For the service center nearest you call 1-800-525-2579.

* Standard Hardware Item – May Be Purchased Locally