

RYOBI 4-1/2 in. (115 mm) ANGLE GRINDER – MODEL NUMBER AG451

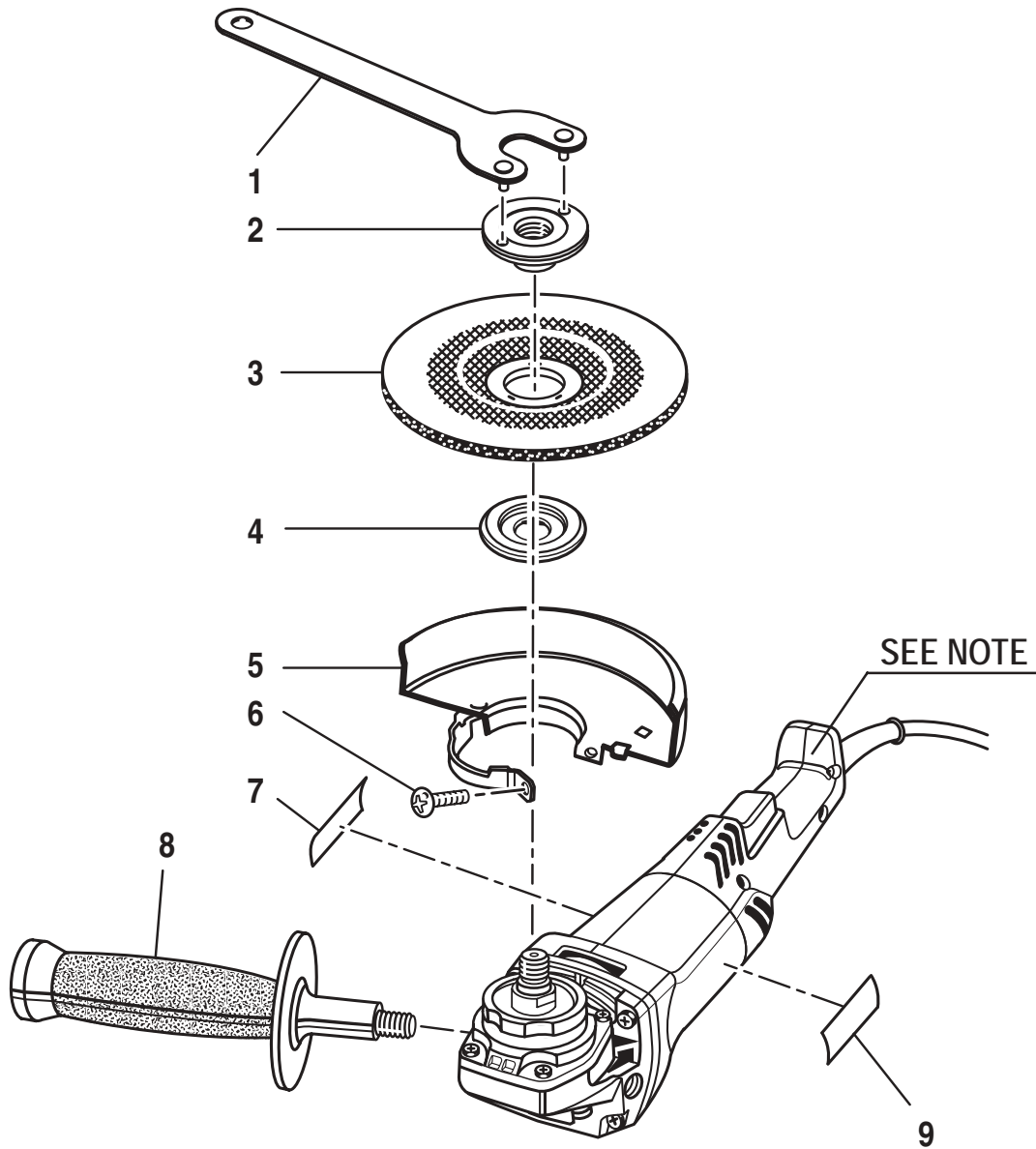

KEY NO.	PART NO.	DESCRIPTION	QTY.
1	AG450-66	WRENCH	1
2	AG451-02	CLAMP NUT	1
3	AG451-64	GRINDING WHEEL	1
4	AG451-01	DISC FLANGE	1
5	AG450-01	GUARD	1
6	AG450-02	CLAMP SCREW (M6 X 15 mm)	1
7	AG450-26	LOGO PLATE	1
8	AG450-65	SIDE HANDLE	1
9	AG451-04	DATA PLATE	1
10	AG450-60	WIRE BRUSH (NOT SHOWN)	1
11	AG451-62	ABRASIVE MOP DISC (NOT SHOWN)	1

NOTE: The assembly shown represents an important part of the double insulated system. To avoid the possibility of alteration or damage to the system, service should be performed by your nearest Ryobi Authorized Service Center. For the service center nearest you call 1-800-525-2579.

RYOBI 4-1/2 in. (115 mm) ANGLE GRINDER – MODEL NUMBER AG451

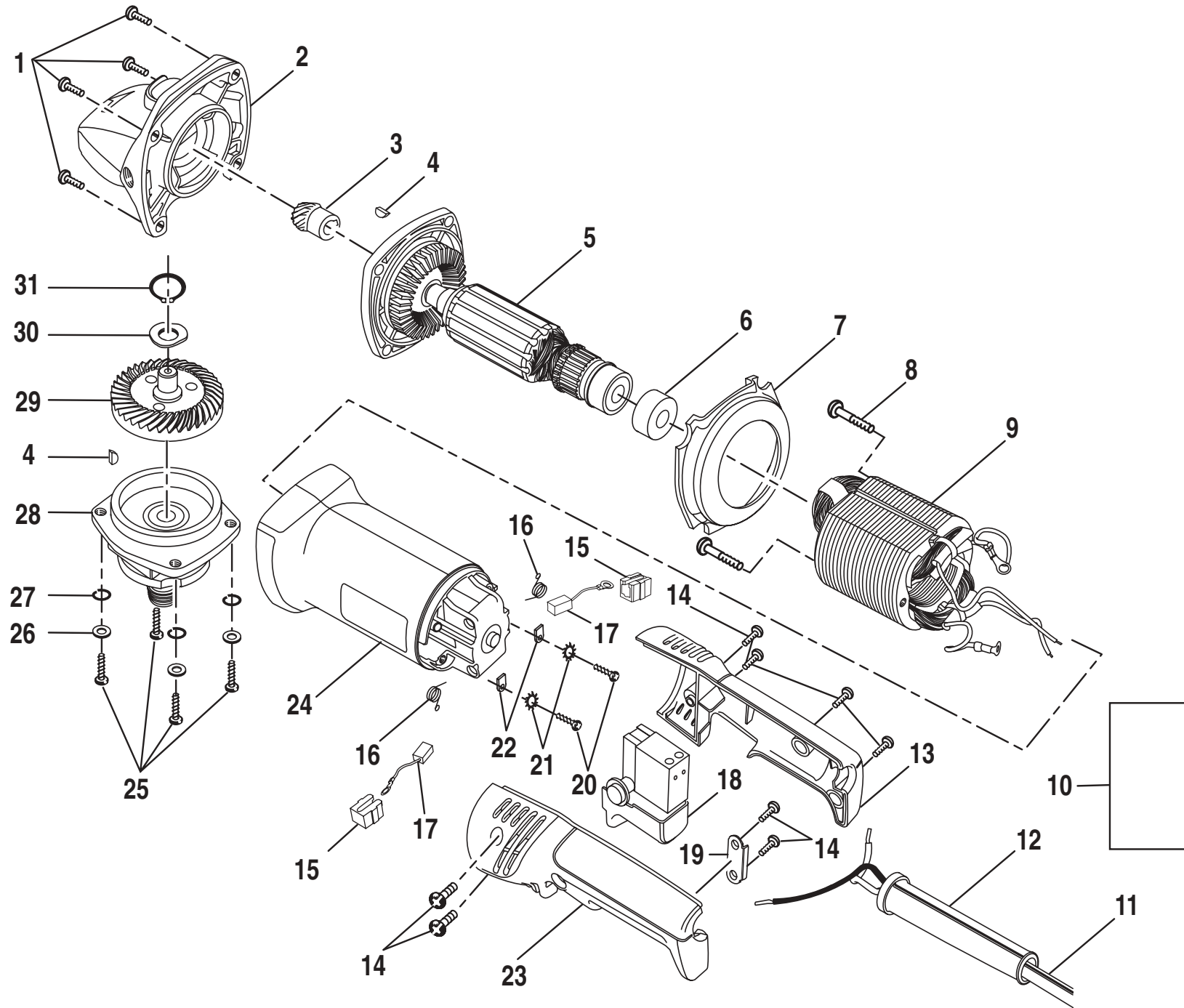

RYOBI 4-1/2 in. (115 mm) ANGLE GRINDER – MODEL NUMBER AG451

The model number will be found on a plate attached to the motor housing. Always mention the model number in all correspondence regarding your **ANGLE GRINDER** or when ordering repair parts.

PARTS LIST

Key No.	Part Number	Description	Qty.	Key No.	Part Number	Description	Qty.
1	AG450-19	* SCREW (M5 X 25 mm)	4	18	AG450-38	SWITCH ASSEMBLY	1
2	AG450-15	GEAR CASE ASSEMBLY	1	19	AG450-32	CORD CLAMP	1
3	AG450-21	BEVEL PINION	1	20	AG450-50	* SCREW (M4 X 10 mm)	2
4	AG450-12	KEY	2	21	AG450-51	* WASHER (M4)	2
5	AG450-40	ARMATURE ASSEMBLY	1	22	AG451-08	CLIP	2
6	AG450-41	BEARING CAP	1	23	AG450-29	HANDLE (LEFT)	1
7	AG450-39	FAN BAFFLE	1	24	AG450-25	MOTOR HOUSING	1
8	AG450-42	SCREW	2	25	AG450-05	* SCREW (M4 X 12 mm)	4
9	AG450-43	FIELD ASSEMBLY	1	26	AG450-06	* WASHER (M4)	4
10	AG450-36	CORD TAG	1	27	AG450-07	* LOCK WASHER (M4)	4
11	AG450-35	POWER CORD	1	28	AG451-03	GEAR CASE COVER ASSEMBLY	1
12	AG450-34	BEND RELIEF	1	29	AG450-10	BEVEL GEAR	1
13	AG450-28	HANDLE (RIGHT)	1	30	AG450-09	WAVY WASHER	1
14	AG450-30	* SCREW (M4.2 X 16 mm)	8	31	AG450-08	RETAINING RING	1
15	AG451-09	BRUSH HOLDER	2	32	AG450-67	CARRYING CASE (NOT SHOWN)	1
16	AG450-48	BRUSH SPRING	2		983000030	OPERATOR'S MANUAL	
17	AG450-45	BRUSH ASSEMBLY	2		983000030R	REPAIR SHEET (REV:00)	
					02-09-05		

WARNING: Improper repair of a double insulated tool can result in damage to the double insulation system possibly causing electrical shock or electrocution. Any repairs requiring disassembly of your tool requires safety testing and should only be performed by a Ryobi Authorized Service Center. For the service center nearest you call 1-800-525-2579.

* Standard Hardware Item – May Be Purchased Locally